

**Exercises in KS3
Mathematics
Levels 7 - 8
R Joinson**

Sumbooks 5 Northway Chester CH4 8BB

Exercises in KS3 Mathematics - Levels 7 and 8

First Published 2001

Copyright R Joinson and **Sumbooks**

This package of worksheets is sold subject to the condition that it is photocopied for educational purposes only on the premises of the purchaser

ISBN **0 9531626 7 2**

Preface

The questions have been arranged, as far as possible, according to level 7 and level 8 of the National Curriculum. All level 7 questions are in the front of the book and all level 8 questions in the back. Pages are labelled L.7 or L.8 accordingly. There may be some overlap of the levels where I have found it unavoidable in order to keep the questions sensible.

I would like to thank my wife Jenny and my daughters Abigail and Hannah for all the help and encouragement they have given me.

R Joinson

September 2001
Chester

Contents

Estimating	7
Powers of Numbers	8
Multiplying and Dividing	9
Percentage Change	10
Fractions	11
Ratio 1	12
Ratio 2	13
Odd and Even Solutions	14
Simplifying 1	15
Simplifying 2	16
Multiplying Brackets Together	17
Factorising	18
Solving Simple Equations	19
Sequences	20
Trial and Improvement	21
Graphs	22
Simultaneous Equations with Graphs	23
Simultaneous Equations	24
Solving Simultaneous Equations	25
Inequalities	26
Pythagoras' Theorem	27
Areas of Right Angled Triangles	28
Areas of Plane Shapes	29
Volumes of Prisms	30
Enlargement and Similarity	31
Routes	32
Trees	33
Rounding Off	34
Imprecision of Measurement	35
Compound Measure	36
Currency	37
Coach Journey	38
Train Journey	39
Road Race	40
Mean	41
Mean and Range	42
Sweets	43
Flower Seeds	44
Measuring Scatter	45
Relative Frequency	46
Probability	47
Powers	48
Standard Form 1	49
Standard Form 2	50
Questions in Standard Form	51
Repeated Proportional Change	52
Calculating the Original Amount	53

Proportion	54
Letters and %	55
Substitution	56
How Many Solutions?	57
Formulae	58
Simultaneous Equation Problems	59
Equations from Experimental Data	60
Solving Equations	61
Factorising Expressions	62
Triangular Numbers	63
Graph of $y = x^2$	64
Inequality Questions	65
Areas Bounded by Curves	66
Pythagoras etc	67
Area	68
Areas and Perimeters	69
Volume	70
Congruent Triangles	71
Similar Triangles	72
Angles	73
Sine, Cosine and Tangent Ratios	74
Bearings	75
Calculating Lengths in Triangles	76
More Similarity	77
The Cricket Scores	78
Cumulative Frequency 1	79
Cumulative Frequency 2	80
Cumulative Frequency 3	81
Probability 1	82
Probability 2	83

Estimating

Do not use a Calculator

L.7

1) Estimate each of the following.

- | | | | |
|-----------------------|-----------------------|-----------------------|-----------------------|
| a) 3.85×4.32 | b) 8.29×1.67 | c) 3.74×2.63 | d) 7.13×2.71 |
| e) $8.35 \div 4.2$ | f) $9.32 \div 3.02$ | g) $10.54 \div 3.5$ | h) $7.34 \div 2.4$ |
| i) 5.23×0.12 | j) 6.83×0.53 | k) 5.92×0.29 | l) 8.24×0.73 |
| m) $4.25 \div 0.21$ | n) $7.23 \div 0.56$ | o) $9.45 \div 0.45$ | p) $6.93 \div 0.5$ |
| q) 23.4×2.91 | r) 33.5×2.74 | s) 73.4×5.34 | t) 86×1.95 |
| u) $82 \div 4.97$ | v) $63.8 \div 3.1$ | w) $73.2 \div 7.2$ | x) $93.4 \div 7.35$ |

2) Estimate the sizes of the following.

- | | | |
|---|--|--|
| a) $\frac{3.74 + 2.75}{5.35 + 0.54}$ | b) $\frac{18.53 + 6.94}{5.43 + 6.17}$ | c) $\frac{19.85 + 24.54}{1.75 + 6.94}$ |
| d) $\frac{15.23 - 8.24}{1.43 + 6.17}$ | e) $\frac{13.27 - 3.84}{7.43 - 3.67}$ | f) $\frac{23.67 + 12.32}{12.05 - 5.43}$ |
| g) $\frac{5.91 \times 5.12}{3.16}$ | h) $\frac{12.3 \times 7.12}{9.43}$ | i) $\frac{8.43 \times 6.4}{8.32}$ |
| j) $\frac{17 \times 3.53}{7.61}$ | k) $\frac{25 \times 1.95}{5.26}$ | l) $\frac{49.5 \times 5.23}{3.85}$ |
| m) $\frac{7.8 \times 2.93}{1.74 \times 3.42}$ | n) $\frac{5.73 \times 4.31}{2.64 \times 1.78}$ | o) $\frac{5.63 \times 8.43}{3.84 \times 2.74}$ |
| p) $\frac{18.49 \times 4.29}{8.73 \times 1.92}$ | q) $\frac{7.38 \times 4.47}{6.73 \times 2.17}$ | r) $\frac{12.2 \times 4.73}{6.12 \times 2.74}$ |

3) In each of the following write down the number you consider to be the best estimate.

- | | | | | | | | |
|-------------------------|-----------|-------|------|-----|-----|------|--------|
| a) $34.6 \div 3.74$ | Estimates | 6 | 7 | 8 | 9 | 10 | 11 |
| b) $12.7 \div 0.54$ | Estimates | 16 | 18 | 20 | 22 | 24 | 26 |
| c) 4.42×0.28 | Estimates | 1.1 | 1.2 | 1.3 | 1.4 | 1.5 | 1.6 |
| d) 73.6×0.0072 | Estimates | 0.4 | 0.5 | 0.6 | 0.7 | 0.8 | 0.9 |
| e) $285 \div 0.57$ | Estimates | 0.05 | 0.5 | 5 | 50 | 500 | 5,000 |
| f) 23×0.032 | Estimates | 0.07 | 0.07 | 0.7 | 7 | 70 | 700 |
| g) 213×0.21 | Estimates | 0.4 | 4 | 40 | 400 | 4000 | 40,000 |
| h) $3.21 \div 0.24$ | Estimates | 0.15 | 1.5 | 15 | 150 | 1500 | 15,000 |
| i) $92.5 \div 0.45$ | Estimates | 0.02 | 0.2 | 2 | 20 | 200 | 2000 |
| j) $156 \div 0.34$ | Estimates | 0.05 | 0.5 | 5 | 50 | 500 | 5000 |
| k) 364×0.63 | Estimates | 2,400 | 240 | 24 | 2.4 | 0.24 | 0.024 |

Powers of Numbers

Do not use a calculator.

L.7

1) Rearrange the following into order of size, smallest first.

2^2	7^2	5^3	5^1	4^2	4^4	3^3
4^6	5^5	5^4	8^2	4^3	2^5	3^5

2) Which of the following are not square numbers?

4^7	4^9	3^8	5^7	2^9	4^4	6^5
6^6	9^4	3^7	5^2	7^1	8^6	9^3

3) Which of the following are equal to 2^6 ?

6^3	4^3	8^2	3^4	2^8	6^2
-------	-------	-------	-------	-------	-------

4) If $3^{10} = 59049$, write down the values of these.

3^9	3^8	3^{11}	3^{12}	9^6	9^5	9^4	81^3
-------	-------	----------	----------	-------	-------	-------	--------

5) If $4^{10} = 1048576$, complete each of the following.

$$262144 = 4^?$$

$$262144 = 2^?$$

$$4194304 = 4^?$$

$$1048576 \div 2 = 2^?$$

6) Which of the following are true?

a) $2^{20} = 4^{10}$

b) $4^{10} = 8^5$

c) $4^{10} = 6^5$

d) $4^{10} = 1^{40}$

e) $5 \times 2^{20} = (5 \times 2)^{20}$

f) $3^{10} = 9^5$

g) $4^3 = 3^4$

h) $2^4 = 4^2$

Multiplying and Dividing

Do not use a Calculator

L.7

1) In each of these calculations the answer is 5. Write down the missing numbers.

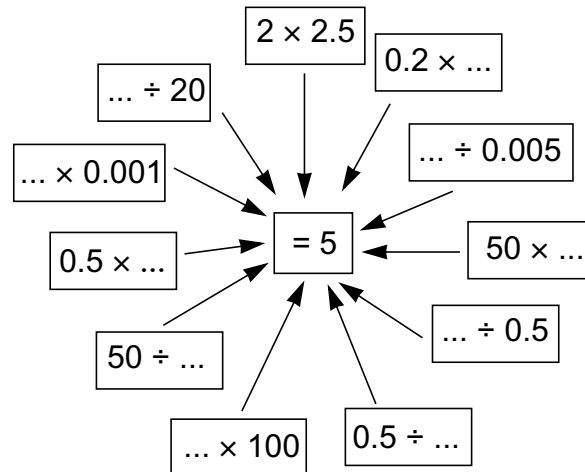

2) Look at these number cards.



- Which two cards give the lowest answer when multiplied together?
- Which two cards give an answer of 10 when divided?
- Which two cards give the smallest possible answer when divided?
- Which two cards give the greatest answer when multiplied together?
- Which two cards give the greatest answer when divided?
- Write down a second way in which 10 can be obtained by dividing.
- How can 2, 0.05 and 10 be put together to get an answer of 19.95?
- How can 0.4, 0.01 and 0.2 be put together to get an answer of 200?
- How can 0.01, 10 and 4 be put together to get an answer of 0.025?

3) Complete each of the following.

- | | |
|------------------------------|----------------------------|
| a) $\dots \times 0.01 = 100$ | b) $\dots \div 0.01 = 100$ |
| c) $0.02 \times \dots = 100$ | d) $0.6 \div \dots = 100$ |
| e) $\dots \times 3 = 0.18$ | f) $\dots \div 2 = 0.45$ |
| g) $2 \times \dots = 0.01$ | h) $0.5 \div \dots = 10$ |
| i) $\dots \times 0.25 = 100$ | j) $\dots \div 0.35 = 3$ |
| k) $2.2 \times \dots = 110$ | l) $0.56 \div \dots = 200$ |
| m) $\dots \times 0.05 = 700$ | n) $\dots \div 2.5 = 0.4$ |
| o) $0.004 \times \dots = 50$ | p) $7.5 \div \dots = 250$ |
| q) $\dots \times 22 = 5.5$ | r) $\dots \div 1.25 = 0.8$ |

Percentage Change

Round off your answer sensibly wherever necessary.

L.7

- 1) The population of a town during the second half of the 20th century is shown in the table below.

Year	Population
1950	15,430
1960	18,218
1970	27,045
1980	26,453
1990	28,564
2000	35,843

- What was the rise in population between 1950 and 2000?
 - What was the percentage rise in population between 1950 and 2000?
 - There was a fall in the population between 1970 and 1980. What was this percentage fall?
 - It is expected that the population will fall by 12% between 2000 and 2010. What is the expected population for 2010?
- 2) In the general elections of 1997 and 2001, the percentage of the voters who supported the three main parties are shown in the table below.

Party	1997	2001
Labour	42.88%	42.08%
Conservative	30.91%	32.79%
Liberal Democrat	16.92%	18.85%
Other Parties	8.99%	6.27%

- Why does the total percentage of votes cast in 1997 not equal 100?
 - In 1997 the total number of votes cast was 31,160,128. How many people voted for each of the three main parties in 1997?
 - What was the percentage increase in the Liberal Democrats share of the vote in 2001 compared with 1997?
- 3) In 1999 a company made a profit of £103,345. In 2000 its profit was £124,678.
- What was its increase in profit?
 - What was its percentage increase in profit?
- In the first half of 2001 it made a profit of £47,450. It was expected to make the same profit in the second half of the year.
- What was the expected profit for 2001?
 - What was the expected percentage decrease in profit for 2001 compared with 2000?

Fractions

L.7

- 1) A tank contains 10,000 litres of water when full. It begins to leak. After the first day half of the water is lost. After the second day half of the remainder is lost. After the third day half of the remainder from the second day is lost. This continues, losing half of the remainder from the previous day.
At the end of 5 days the leak is discovered.
- What fraction of the water has been lost?
 - What fraction of the water remains?
 - How much water has to be put back into the tank in order to fill it up?
- 2) A cake is cut up into a number of equal pieces. Alan, Bethan, Clive and Deborah take pieces of the cake.
Alan has $\frac{1}{3}$ of the cake. Bethan has $\frac{1}{4}$ of the cake. Clive has $\frac{1}{6}$ of the cake. Deborah now takes one third of the remainder. This leaves two pieces. How many pieces was the cake cut into?
- 3) Afram travels by car to Italy. On the first day he travels 350 miles. On the second day he travels 250 miles and on the third day he travels 280 miles. If he now has $\frac{4}{15}$ of his journey left to do, what is the total length of his journey?
- 4) The list below shows how Marie spends her weekly wages.

	Proportion of wages
Rent	$\frac{2}{7}$
Shopping	$\frac{5}{28}$
Clothes	$\frac{1}{28}$
Energy (Electricity etc)	$\frac{1}{14}$
Transport	$\frac{1}{14}$
Luxuries and Entertainment	$\frac{1}{7}$
Other	

- What fraction of her weekly wages is spent on 'other'?
 - If Marie spends £20 on transport, what is her total weekly wage?
- 5) Biscuits occupy $\frac{7}{8}$ th of the volume of their packet. The remaining $\frac{1}{8}$ is unused. It is decided to re-design the packet so that the amount of unused space is reduced by 40%. What fraction of the packet will the biscuits now take up?

Ratio 1

L.7

- 1) The table below shows some information about the 6th form students of a school.

	Can speak French	Can't speak French
Boys	23	81
Girls	34	72

- a) How many pupils are there in the 6th form?
 b) What is the ratio of those who can speak French to those who can't?

1 :

- 2) The scale on a map is 1 : 25,000.

This indicates that an actual distance of 25,000 centimetres (250 metres) is represented by 1 centimetre on the map.

- a) What distance on the map will represent an actual distance of 1 kilometre?
 b) A road measures 5.6cm on the map. What is its actual length?
 c) Gwyn walks a distance of 8.7km along the side of the canal. Approximately how long is this on the map?

- 3) Below are shown the areas of the parts of the British Isles. (The Isle of Man and the Channel Islands have been left out)

Country	Area in square kilometres
Wales	20,761
Ireland	70,285
Scotland	78,772
England	130,360

Complete this ratio for the four countries which shows their relative sizes.

Wales : Ireland : Scotland : England

1 : : :

- 4) Four cubes, each of exactly the same size (congruent), are made from four different metals. The ratio of their masses is shown below.

Aluminium : Titanium : Copper : Lead
 1 : 1.67 : 3.31 : 4.2

- a) If the aluminium cube has a mass of 0.7kg, what are the masses of the other cubes?
 b) Another bigger shape is made. Again exactly the same size for each of the materials.
 If the titanium shape has a mass of 4.5kg, what is the mass of the copper shape?

Ratio 2

L.7

1) Halla mixes paint. She wants to make pale green. These are the colours she uses.

135ml of blue
120ml of yellow
45ml of white.

a) How much of each colour is in 100ml of the mixture?

Winston mixes paint to get a pale green. These are the colours he uses

115ml of blue
105ml of yellow
30ml of white.

b) How much of each colour is in 100ml of the mixture?

c) Which of the two mixtures is the paler?

2) A biscuit bar has the following information printed on the side of its packet.

TYPICAL NUTRITION	PER 45g BAR	PER 100g
Energy	824kj/197kC	a
Protein	b	8.4g
Carbohydrate	26.7g	59.2g
Fat	9.3g	c
Fibre	d	7.3g
Sodium	0.03g	0.06g

Complete the table by putting in the values a, b, c and d.

3) Bridget buys a longlife bulb. It costs £5. The packet has the following information printed on the side.

A longlife bulb uses 15 watts of electricity per hour and lasts for 8,000 hours.

An ordinary bulb uses 75 watts per hour and lasts for 1,000 hours.

a) How many watts of electricity does a longlife bulb use in its lifetime?

b) How many watts of electricity does a normal bulb use in its lifetime?

c) Complete this ratio for the amount of electricity used by each type of bulb in 8,000 hours.

Longlife bulb : Ordinary bulb

1 : ...

d) An ordinary bulb costs 25p. Complete this ratio for the cost of the bulbs for 8,000 hours.

Longlife bulb : Ordinary bulb

... : 1

e) Is it economical to buy a longlife bulb in preference to an ordinary one? Explain your answer.

Odd and Even Solutions

L.7

1) n is an even number. Which of the following are even?

- | | | | |
|---------------------|-------------|---------------------|---------------------|
| a) $n + 1$ | b) $n + 2$ | c) n^2 | d) $n^2 + 1$ |
| e) $(n + 1)^2$ | f) $n - 1$ | g) $n - 2$ | h) $(n - 2)^2$ |
| i) $(n + 1)(n - 1)$ | j) $n - 3$ | k) $4n$ | l) $5n$ |
| m) $n^2 - 1$ | n) $3n - 1$ | o) $(n - 1)(n - 2)$ | p) $(n + 1)(n - 2)$ |

2) If n is an odd number, what kind of number, odd, even, either or neither, must m be in each of the following in order for the expression to be even?

- | | | | |
|---------------------|----------------|----------------|----------------|
| a) $n + m$ | b) $n - m$ | c) $m + 2n$ | d) $(n + m)^2$ |
| e) $(n + m)(n - m)$ | f) $2n^2 - 3m$ | g) $n + m^2$ | h) $4n + 2m^2$ |
| i) $n^2 + m$ | j) $3n + 2m$ | k) $(n - m)^2$ | l) $m - n$ |

3) In the following expressions x is an odd number greater than 1. Which of the expressions always give whole number answers and which don't?

- | | | | |
|-----------------------|-----------------------|-----------------------|-----------------------|
| a) $\frac{x + 1}{2}$ | b) $\frac{x - 1}{2}$ | c) $\frac{3x}{2}$ | d) $\frac{2x + 1}{2}$ |
| e) $\frac{3x + 1}{2}$ | f) $\frac{2x - 1}{2}$ | g) $\frac{6x + 4}{3}$ | h) $\frac{6x + 1}{3}$ |

4) Use this table to answer the questions below.

$n =$	1	2	3	4	5	6	7	8
n^2	1	4	9	16	25	36	49	64
$(n - 1)^2$	0	1	4	9	16	25	36	49
$(n - 2)^2$		0	1	4	9	16	25	36
$(n - 3)^2$			0	1	4	9	16	25
$(n - 4)^2$				0	1	4	9	16
$(n - 5)^2$					0	1	4	9
$(n - 6)^2$						0	1	4
$(n - 7)^2$							0	1

- a) Complete the table.
- b) Explain which expressions give odd answers.
- c) Explain which expressions give even answers.
- d) Explain what is required in an expression to get 9 as an answer.
- e) What type of numbers would n and y have to be for $(n - y)^2$ to be even?

Simplifying 1

L.7

1) Simplify each of the following expressions

a) $5a + 7a$

b) $12x - 6x$

c) $24w + 3w - 6w$

d) $32y - 16y + 7y$

e) $24x + 71x - 35x$

f) $-14n + 7n - 16n$

g) $-35b - 23b - 4b$

h) $31x + 13x - 27x$

i) $-3p + 7p - 6p$

j) $5z + 3z - 15z$

k) $3x + 2y - x + 2y$

l) $3p - 2q - 2p + 3q$

m) $14w + 4x - 13w - 4x$

n) $-5f - 7g + f + 7g$

o) $5k - 7k - 4m + 2m$

p) $2x + 21 - 3x - 23$

q) $34 - 3m + 21 - 7m$

r) $7x - 2 - 3x - 6$

2) Simplify

a) $2a^2 + 3a + 4a^2 + 3a$

b) $5y + 3y^2 - 2y + 4y^2$

c) $4b^2 + b + 7b^2 - 5b$

d) $a^2 + 2y + 3a^2 + y$

e) $6x + 2x^2 - 4x + 5x^2$

f) $2c^2 + bc + 5c^2 - 3bc$

g) $-3x^2 + 2x + 7x^2 + x$

h) $6b + 2b^2 - 3b + b^2$

i) $-6c^2 - b + 3c^2 - 2b$

j) $5y^2 + 6y - 2y^2 + 4y$

k) $6xy + 2y^2 - 4xy + 6y^2$

l) $7d^2 - cd + 3d^2 - 4cd$

m) $3y^2 - 2y + 3y + 5$

n) $-6a - 2a^2 - 4a + 7a^2$

o) $7c^2 - c + 6c - 11$

3) Simplify these fractions

a) $\frac{1}{2}a + \frac{1}{4}a$

b) $\frac{1}{4}x + \frac{3}{4}x$

c) $\frac{3}{4}y + \frac{1}{2}y$

d) $\frac{1}{3}a + \frac{1}{6}a$

e) $\frac{1}{5}c + \frac{3}{10}c$

f) $\frac{1}{2}y - \frac{1}{4}y$

g) $\frac{3}{4}a - \frac{1}{4}a$

h) $\frac{3}{4}b - \frac{1}{2}b$

i) $\frac{3}{8}x - \frac{1}{4}x$

j) $\frac{3}{4}c - \frac{5}{8}c$

k) $\frac{1}{4}a - \frac{3}{4}a$

l) $\frac{3}{5}y - \frac{1}{10}y$

m) $\frac{1}{4}a - \frac{1}{2}a$

n) $\frac{7}{10}x - \frac{1}{2}x$

o) $\frac{5}{9}c - \frac{2}{3}c$

p) $\frac{7}{12}b - \frac{3}{4}b$

4) Simplify these fractions

a) $\frac{c}{5} + \frac{3c}{10}$

b) $\frac{2x}{3} + \frac{x}{6}$

c) $\frac{c}{5} + \frac{c}{15}$

d) $\frac{w}{5} + \frac{2w}{15}$

e) $\frac{b}{8} + \frac{b}{12}$

f) $\frac{3a}{8} + \frac{3a}{8}$

g) $\frac{x}{4} + \frac{3x}{8}$

h) $\frac{y}{12} + \frac{3y}{4}$

i) $\frac{9y}{10} - \frac{3y}{10}$

j) $\frac{c}{5} - \frac{c}{10}$

k) $\frac{a}{2} - \frac{a}{4}$

l) $\frac{3x}{4} - \frac{x}{4}$

m) $\frac{7c}{8} - \frac{c}{4}$

n) $\frac{y}{3} - \frac{y}{6}$

o) $\frac{b}{2} - \frac{b}{6}$

p) $\frac{c}{4} - \frac{c}{12}$

5) Which of these is equal to $\frac{1}{2}c$?

a) $\frac{c}{8} + \frac{c}{12}$

b) $\frac{c}{3} + \frac{c}{6}$

c) $\frac{c}{2} - \frac{c}{6}$

d) $\frac{5c}{6} - \frac{c}{3}$

e) $\frac{2c}{5} + \frac{2c}{15}$

f) $\frac{c}{5} + \frac{3c}{10}$

g) $\frac{c}{3} - \frac{c}{6}$

h) $\frac{3c}{8} + \frac{3c}{8}$

i) $\frac{c}{4} + \frac{3c}{8}$

j) $\frac{c}{12} + \frac{3c}{4}$

k) $\frac{9c}{10} - \frac{2c}{5}$

l) $\frac{c}{2}$

m) $\frac{3c}{4} + \frac{c}{4}$

n) $\frac{3c}{4} - \frac{c}{4}$

o) $\frac{7c}{8} - \frac{3c}{8}$

p) $\frac{3c}{4} - \frac{3c}{12}$

Simplifying 2

L.7

1) Simplify these fractions

a) $\frac{3}{9}$ b) $\frac{5}{15}$ c) $\frac{6}{9}$ d) $\frac{4}{8}$ e) $\frac{6}{10}$ f) $\frac{8}{12}$ g) $\frac{12}{16}$
 h) $\frac{5}{20}$ i) $\frac{10}{25}$ j) $\frac{8}{14}$ k) $\frac{12}{30}$ l) $\frac{8}{18}$ m) $\frac{9}{24}$ n) $\frac{6}{20}$

2) Simplify these multiplications

a) $\frac{1}{3} \times \frac{2}{3}$ b) $\frac{1}{2} \times \frac{1}{4}$ c) $\frac{2}{3} \times \frac{1}{5}$ d) $\frac{3}{5} \times \frac{2}{7}$
 e) $\frac{3}{5} \times \frac{2}{3}$ f) $\frac{1}{2} \times \frac{6}{7}$ g) $\frac{3}{4} \times \frac{2}{3}$ h) $\frac{4}{9} \times \frac{3}{8}$
 i) $\frac{5}{8} \times \frac{4}{15}$ j) $\frac{3}{4} \times \frac{5}{9}$ k) $\frac{3}{10} \times \frac{1}{3}$ l) $\frac{5}{9} \times \frac{3}{10}$

3) Simplify these fractions

a) $\frac{2a}{4}$ b) $\frac{4x}{12}$ c) $\frac{3c}{9}$ d) $\frac{2y}{8}$ e) $\frac{4b}{12}$ f) $\frac{4a}{16}$ g) $\frac{9x}{24}$
 h) $\frac{6a}{10}$ i) $\frac{8y}{26}$ j) $\frac{14a}{20}$ k) $\frac{5x}{25}$ l) $\frac{9a}{15}$ m) $\frac{8c}{20}$ n) $\frac{4y}{10}$
 o) $\frac{2a}{2}$ p) $\frac{5x}{25}$ q) $\frac{18a}{27}$ r) $\frac{4y}{35}$ s) $\frac{8a}{32}$ t) $\frac{9c}{30}$ u) $\frac{6y}{16}$

4) Simplify these fractions

a) $\frac{2ab}{a}$ b) $\frac{b}{9b}$ c) $\frac{xy}{3xy}$ d) $\frac{y}{6xy}$ e) $\frac{5b}{ab}$ f) $\frac{4x}{xyz}$
 g) $\frac{4ab}{2a}$ h) $\frac{5b}{15b}$ i) $\frac{3xy}{9xy}$ j) $\frac{3x^2y}{4xy}$ k) $\frac{2b}{6ab}$ l) $\frac{3xy}{4xyz}$
 m) $\frac{2a^2}{4}$ n) $\frac{2a^2}{a}$ o) $\frac{3x^2y}{xy}$ p) $\frac{3y}{12xy}$ q) $\frac{2a^2b}{a}$ r) $\frac{2xy^2}{14xy}$

5) Arrange the following into pairs that are equal to each other

$\frac{a}{b}$ $\frac{ab}{a^2bc}$ $\frac{a^2}{ab}$ $\frac{3y}{9xy}$ $\frac{xy}{xy}$ $\frac{2axy}{a^2}$
 $\frac{y}{y}$ $\frac{3}{3xy}$ $\frac{2x}{2x^2y}$ $\frac{5b}{ab}$ $\frac{c}{ab}$ $\frac{x}{x^2yz}$
 $\frac{8xy}{4a}$ $\frac{c^2}{abc}$ $\frac{5c}{ac}$ $\frac{2y}{6xy}$ $\frac{b}{abc}$ $\frac{y}{xy^2z}$

Multiplying Brackets Together

L.7

1) Remove the brackets and simplify.

- | | | |
|---------------------------|----------------------------|----------------------------|
| a) $2(x + 4) + (x + 6)$ | b) $3(x + 3) + (x + 7)$ | c) $3(x + 3) - (x + 2)$ |
| d) $4(x + 4) - (x - 3)$ | e) $3(x + 2) + (x - 6)$ | f) $7(x + 3) - 2(x - 5)$ |
| g) $5(x - 10) + 3(x + 3)$ | h) $6(x - 5) + 4(x + 5)$ | i) $3(x - 1) - 3(x + 9)$ |
| j) $9(x - 3) + 4(x - 5)$ | k) $7(x - 7) - (x - 4)$ | l) $6(x - 6) - 4(x - 7)$ |
| m) $4(2x - 5) + 5(x + 6)$ | n) $3(4x - 2) + 7(x + 7)$ | o) $3(x - 3) - 6(3x + 5)$ |
| p) $8(x - 4) + 2(4x - 6)$ | q) $4(2x - 8) - 2(3x - 4)$ | r) $6(6x - 3) - 4(2x - 8)$ |

2) Multiply together each pair of brackets and simplify your answer

- | | | |
|----------------------|---------------------|----------------------|
| a) $(x + 2)(x + 3)$ | b) $(x + 4)(x + 5)$ | c) $(x + 3)(x + 7)$ |
| d) $(x + 5)(x - 6)$ | e) $(x + 7)(x - 4)$ | f) $(x + 2)(x - 8)$ |
| g) $(x - 12)(x + 2)$ | h) $(x - 8)(x + 6)$ | i) $(x - 10)(x + 3)$ |
| j) $(x - 4)(x - 9)$ | k) $(x - 3)(x - 6)$ | l) $(x - 5)(x - 4)$ |

3) Multiply together each pair of brackets and simplify your answer

- | | | |
|----------------------|----------------------|----------------------|
| a) $(2x + 1)(x + 4)$ | b) $(3x + 4)(x + 3)$ | c) $(2x + 5)(x + 2)$ |
| d) $(4x + 2)(x - 3)$ | e) $(2x + 5)(x - 3)$ | f) $(5x + 3)(x - 5)$ |
| g) $(5x - 3)(x + 6)$ | h) $(6x - 8)(x + 2)$ | i) $(3x - 7)(x + 4)$ |
| j) $(6x - 2)(x - 3)$ | k) $(5x - 7)(x - 1)$ | l) $(4x - 4)(x - 7)$ |

4) Multiply together each pair of brackets and simplify your answer

- | | | |
|----------------------|----------------------|----------------------|
| a) $(x + 2)(2x + 5)$ | b) $(x + 3)(4x + 2)$ | c) $(x + 6)(3x + 3)$ |
| d) $(x + 1)(5x - 5)$ | e) $(x + 6)(2x - 4)$ | f) $(x + 4)(4x - 4)$ |
| g) $(x - 5)(5x + 3)$ | h) $(x - 6)(3x + 9)$ | i) $(x - 3)(6x + 9)$ |
| j) $(x - 2)(9x - 5)$ | k) $(x - 3)(2x - 8)$ | l) $(x - 9)(6x - 6)$ |

5) Multiply together each pair of brackets and simplify your answer

- | | | |
|-----------------------|-----------------------|-----------------------|
| a) $(3x + 4)(4x + 9)$ | b) $(5x + 4)(2x + 8)$ | c) $(6x + 4)(2x + 6)$ |
| d) $(5x + 3)(4x - 7)$ | e) $(6x + 3)(4x - 8)$ | f) $(6x + 9)(4x - 8)$ |
| g) $(5x - 1)(8x + 4)$ | h) $(4x - 9)(6x + 6)$ | i) $(8x - 3)(3x + 5)$ |
| j) $(5x - 6)(5x - 3)$ | k) $(3x - 3)(8x - 6)$ | l) $(6x - 7)(4x - 5)$ |

6) Multiply out these squares and simplify your answers

- | | | | |
|-----------------|-----------------|-----------------|-----------------|
| a) $(x + 2)^2$ | b) $(x + 5)^2$ | c) $(x - 1)^2$ | d) $(x - 4)^2$ |
| e) $(x + 1)^2$ | f) $(x + 12)^2$ | g) $(x - 7)^2$ | h) $(x - 5)^2$ |
| i) $(3x + 3)^2$ | j) $(5x + 6)^2$ | k) $(4x - 4)^2$ | l) $(6x - 3)^2$ |
| m) $(2x + 2)^2$ | n) $(3x + 2)^2$ | o) $(5x - 2)^2$ | p) $(4x - 3)^2$ |

Factorising

L.7

1) Write down the factors of these.

- | | | | | |
|-----------|----------|-----------|----------|------------|
| a) 6 | b) 12 | c) ab | d) $3a$ | e) $6a$ |
| f) a^2 | g) $12b$ | h) $4a^2$ | i) $2ab$ | j) $4ab$ |
| k) $4x^2$ | l) $7b$ | m) $6c^2$ | n) $8xy$ | o) $5a^2b$ |

2) Write down the highest common factor of each of the following pairs of expressions.

- | | | |
|-------------------------|-------------------------|-------------------------|
| a) 8 and 12 | b) 9 and 18 | c) 8 and 20 |
| d) $3b$ and 9 | e) $3b$ and $9b$ | f) $3a$ and a^2 |
| g) $5ab$ and $3ab$ | h) $6ab$ and $9a^2$ | i) $4ab$ and $6ab$ |
| j) $6a^2$ and $4a$ | k) $4x^2$ and $3x$ | l) $6xy$ and $9x^2y^2$ |
| m) $3x^2y$ and $18xy^2$ | n) $8a^2b$ and $12ab^2$ | o) $9ac$ and $24a^2c^2$ |

3) Factorise each of the following expressions by finding the highest common factor.

- | | | |
|------------------|-----------------|--------------------|
| a) $2a + 4$ | b) $3x + 6$ | c) $14x + 16$ |
| d) $6x - 4$ | e) $2xy + 2y$ | f) $4ab - 3b$ |
| g) $5ab - 10b$ | h) $6ac - 12$ | i) $5x^2 - 10xy$ |
| j) $2ab + a^2$ | k) $xy - 2y^2$ | l) $3a^2 - 6a$ |
| m) $12a^2 - abc$ | n) $12x^2 + 6x$ | o) $ab + abc + ac$ |

4) Factorise each of the following expressions by finding the highest common factor.

- | | | |
|--------------------------|---------------------------|--------------------------|
| a) $3xy + 2x^2$ | b) $2x^2y + 4y$ | c) $4ab - ac + 3ad$ |
| d) $2a + 4b + 6c$ | e) $2a^2 + 6ab - 8a^2b$ | f) $6ab - ac + 3abc$ |
| g) $4x + 2x^2 + 6x^3$ | h) $4a^2 + 3ab + 2ac$ | i) $4a + 6a^2b - 10ab^2$ |
| j) $a^3 + ax - ab$ | k) $2xy + 6y - 4y^2$ | l) $6a^2b - 3ab^2$ |
| m) $3a^2 + 5ab + 6a^2c$ | n) $2a^2 + 8ab - 10a^2b$ | o) $4ab - 16a^2 + 2abc$ |
| p) $3x^2 + 6xy^3 + 9x^2$ | q) $5ab^2 + 5ab + 10bc^2$ | r) $2a + 3a^2b - 5ab^2$ |

Solving Simple Equations

L.7

1) Calculate the value of x in each of the following.

a) $x + 3 = 8$

b) $9 - x = 4$

c) $x - 9 = 14$

d) $-x + 3 = 6$

e) $-x - 3 = 7$

f) $-3 - x = -8$

g) $-4 + x = 7$

h) $6 - x = -10$

i) $-x + 3 = -11$

2) Calculate the values of the letters in the following.

a) $3a + 2 = 8$

b) $9x - 6 = 8$

c) $6 + 7y = 27$

d) $9 - 4b = 1$

e) $6c - 14 = 16$

f) $4w + 6 = 28$

g) $6x = 28$

h) $6x = -36$

i) $7x - 3 = 60$

j) $7 - 2y = -1$

k) $12p - 12 = 120$

l) $24 - 3w = 6$

3) Calculate the value of the letters in each of the following.

a) $\frac{1}{4}x = 12$

b) $\frac{1}{3}a = 5$

c) $\frac{1}{2}b + 2 = 8$

d) $\frac{1}{4}y + 6 = 19$

e) $\frac{1}{2}w + 1 = 19$

f) $\frac{3}{4}x = 6$

g) $\frac{3}{4}y - 5 = 19$

h) $\frac{1}{2}a - 4 = -6$

i) $\frac{a}{4} = 7$

j) $\frac{x}{4} = 10$

k) $\frac{3b}{4} = 9$

l) $\frac{c}{5} + 6 = 12$

4) Calculate the value of the letter in each case.

a) $3(x + 2) = 21$

b) $4(x + 3) = 24$

c) $5(x + 1) = 15$

d) $7(x - 2) = 35$

e) $6(x - 2) = 48$

f) $8(x - 2) = 48$

g) $6(2x + 2) = 36$

h) $9(3x - 2) = 90$

i) $6(2x - 4) = 72$

j) $4(4x + 7) = 44$

k) $8(3x - 1) = 160$

l) $3(2x + 5) = 75$

5) Calculate the value of the letter in each case.

a) $2x + 3 = 3x + 2$

b) $3x + 4 = 4x + 2$

c) $4x + 5 = 2x + 13$

d) $3x - 4 = x + 4$

e) $2x + 7 = 4x - 5$

f) $8x - 5 = x + 23$

g) $x - 6 = 2x - 9$

h) $5x - 2 = 3x + 4$

i) $6x + 4 = 18x - 2$

j) $4x - 1 = 6x - 15$

k) $8x - 8 = 2x - 2$

l) $3x + 5 = 5x - 16$

Sequences

L.7

- 1) Grace arranges discs into rows. She begins with 2 discs in 1 row. She then increases the number of rows by 1 and the number of discs in each row by 1

 1 row
 2 discs

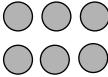
 2 rows
 6 discs

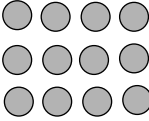
 3 rows
 12 discs

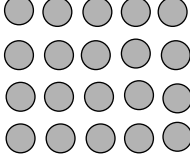
 4 rows
 20 discs

- a) How many discs does she put into 5 rows?
 b) Which of these rules will calculate the number of discs in an arrangement?
 $d = 3r - 3$ $d = 2r - 1$ $d = r \times r + 2$ $d = r(r + 1)$ $d = 4r + 4$
 where d represents the number of discs and r the number of rows.
 c) Use the rule to calculate the number of discs she needs for 10 rows.

- 2) Brian writes down this sequence of numbers

2 6 12 22 30

The rule for finding the next number is $n^2 + n$, where n is the position of the number in the sequence.

- a) Use this rule to check which number in the sequence is incorrect.
 b) Calculate the next two numbers in the sequence.
 c) Brian says that all the numbers in the sequence are even numbers. Explain whether you think he is right.

- 3) Dave writes down this sequence of numbers

$\frac{1}{3}$ $\frac{2}{7}$ $\frac{3}{13}$ $\frac{4}{20}$ $\frac{5}{31}$ $\frac{6}{43}$

The rule for finding the next number is $\frac{n}{n^2 + n + 1}$, where n is the position of the number in the sequence.

- a) Use this rule to check which number in the sequence is incorrect.
 b) Calculate the next two numbers in the sequence.
 c) Explain why the sequence of denominators can never be even.

Trial and Improvement

L.7

The equation $3x^2 - 8x + 2 = 0$ has two solutions for x . One solution is between 2 and 3 and the other is between 0.2 and 0.3.

Derek calculates the values of x by a trial and improvement method. These are his calculations. The difference is obtained by subtracting the value of $3x^2$ from $8x - 2$.

x	$3x^2$	$8x - 2$	Difference
2	12	14	2
2.1	13.23	14.8	1.57
2.2	14.52	15.6	1.08
2.3	15.87	16.4	0.53
2.4	17.28	17.2	-0.08
2.5	18.75	18	-0.75
2.6	20.28	18.8	-1.48
2.7	21.87	19.6	-2.27

- a) Rewrite the equation in the form $3x^2 = \dots$
 b) Why did Derek calculate the difference between $3x^2$ and $8x - 2$?
 c) Between which two values does the solution lie? Explain your answer.
 A more accurate value can be obtained by using values with 2 decimal places.

x	$3x^2$	$8x - 2$	Difference
2.34	16.4268	16.72	0.2932
2.35			
2.36			
2.37			
2.38			
2.39			
2.40			

- d) Continue this table until the difference is negative.
 e) What two values does the solution now lie between?
 f) Write down the first solution to the equation correct to 2 decimal places. Explain why you chose that answer.
 g) Use Derek's method to calculate the second solution to the equation. Give your answer correct to 2 decimal places.

Graphs

L.7

1) Here are the equations of eight graphs labelled A to H.

A $y = 3x + 4$

B $y = 2$

C $y = 3x$

D $x = 2$

E $y = 2x^2$

F $x + y = 12$

G $y = \frac{1}{2}x + 5$

H $\frac{x+y}{2} = 9$

- Which graph is parallel to F?
- Which graph is not a straight line?
- What are the co-ordinates of the point where equations C and F cross?
- Which graph is parallel to the x axis?
- Which two graphs pass through the point $(0,0)$?
- Which graph goes through the point $(4,7)$?
- Which equation is the same as $y = 18 - x$?
- At which point do B and D cross?
- Which graph is parallel to A?
- Which graph crosses D at right angles?
- Which graph is parallel to $y = 0.5x$?

2) The diagram shows a hexagon with corners labelled A to F.

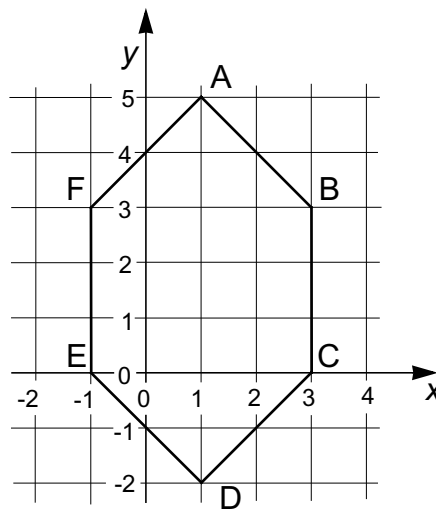

Use the diagram to answer these questions.

- What is the equation of the straight line through F and A?
- What is the equation of the straight line through F and C?
- What is the equation of the straight line through F and B?
- Which two points on the hexagon does the line $y = 2.5(x + 1)$ pass through?
- What are the co-ordinates of the point where the lines $x + y = 6$ and $x = 3$ cross?
- At what point does the line through BC meet the line through ED?
- At what point will the line through CB meet the line through EA?

Simultaneous Equations with Graphs

L.7

1) The diagram below shows the graphs of the equations

$$y = \frac{1}{2}x + 5 \text{ and } y = x + 1$$

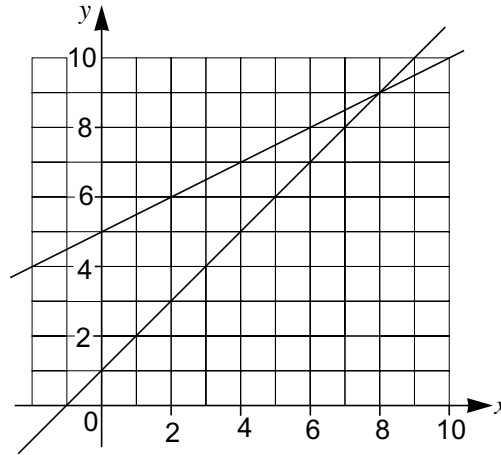

Use the diagram to solve the simultaneous equations:-

$$y - \frac{1}{2}x = 5$$

$$y - x = 1$$

2) The diagram below shows the graphs of two equations:-

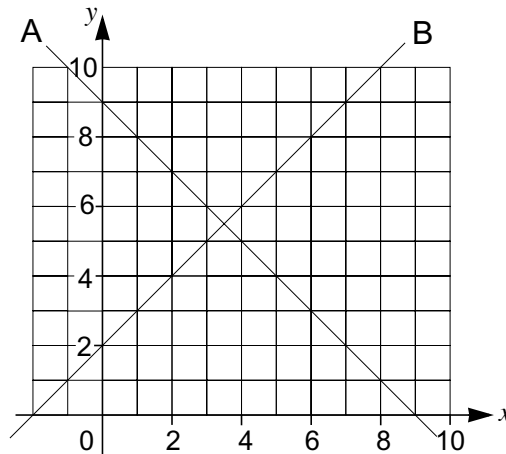

Complete these equations for the two graphs:-

A is $y = \dots$

B is $y = \dots$

Solve the simultaneous equations $y - x = 2$ and $x + y = 9$

3) With a scale of -2 to 5 on the y axis and -4 to 4 on the x axis, draw the graphs of

$$y = 2x + 3 \text{ and } y = \frac{2}{3}x + 1$$

Use the diagram to write down the solution to the simultaneous equations

$$y - 2x = 3 \text{ and } 3y - 2x = 3$$

Simultaneous Equations

L.7

1)

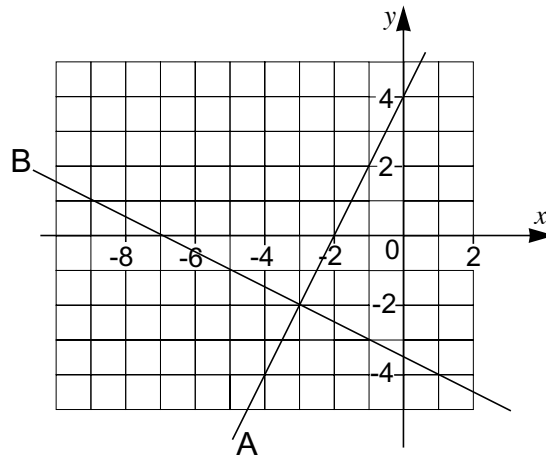

In the diagram above

- Which graph represents the equation $y - 2x = 4$?
- Which graph represents the graph $2y + x = -7$?
- Show that the point of intersection of the two graphs is the solution to the two simultaneous equations:-

$$\begin{aligned} y - 2x &= 4 \\ 2y + x &= -7 \end{aligned}$$

- With a scale of -2 to 7 on the y axis and 0 to 9 on the x axis, draw the graphs of $y = x - 2$ and $y = \frac{1}{2}x + 2$

Use the diagram to write down the solution to the simultaneous equations:-

$$\begin{aligned} y - x &= -2 \\ 2y - x &= 4 \end{aligned}$$

- With a scale of -4 to 7 on the y axis and -5 to 3 on the x axis, draw the graphs of $y = 2x + 4$ and $y = \frac{1}{3}x - 1$

Use the diagram to write down the solution to the simultaneous equations:-

$$\begin{aligned} 3y - x &= -3 \\ y - 2x &= 4 \end{aligned}$$

- With a scale of 0 to 6 on the y axis and -6 to 0 on the x axis, draw the graphs of $y = x + 6$ and $y = -3x - 4$

Use the diagram to write down the solution to the simultaneous equations:-

$$\begin{aligned} y - x &= 6 \\ y + 3x &= -4 \end{aligned}$$

Solving Simultaneous Equations

L.7

Solve the following pairs of simultaneous equations

1) a) $x + 2y = 5$
 $x + y = 3$

b) $x + 4y = 22$
 $x + y = 7$

c) $x + 4y = 13$
 $x + 2y = 7$

d) $4x + 2y = 14$
 $x + 2y = 5$

e) $3x + y = 19$
 $x + y = 9$

f) $3x + 4y = 16$
 $3x + y = 13$

2) a) $+y = 10$
 $-y = 4$

b) $2x + y = 10$
 $x - y = -1$

c) $4x + y = 13$
 $2x - y = 5$

d) $8x - 6y = 28$
 $3x + 6y = 27$

e) $3x - 2y = 3$
 $2x + 2y = 12$

f) $5x + 2y = 13$
 $4x - 2y = 5$

3) a) $x - y = 3$
 $x - 2y = 0$

b) $4x - y = 4$
 $3x - y = 2$

c) $5x - 3y = 14$
 $2x - 3y = 2$

d) $3x - 2y = 12$
 $3x + 2y = 24$

e) $2x - y = 13$
 $2x + 6y = 20$

f) $3x - 4y = -15$
 $3x + 2y = 21$

4) a) $x + 2y = 11$
 $x - 2y = -5$

b) $x + 3y = 17$
 $x - 3y = -13$

c) $2x - 3y = 0$
 $x - 2y = -2$

d) $-3x + 2y = -7$
 $2x - y = 5$

e) $4x + 2y = 18$
 $x - y = -3$

f) $4x + 2y = 26$
 $3x - y = 12$

5) a) $2x + 3y = 7$
 $3x + 5y = 18$

b) $2x + 5y = 14$
 $3x - 2y = 2$

c) $7x - 2y = -20$
 $3x + 4y = 6$

d) $2x + y = 3$
 $-3x - 4y = -2$

e) $2x - 3y = -15$
 $x + 3y = -3$

f) $5x - 2y = 5$
 $-2x - 3y = -2$

6) Calculate the coordinates of the point of intersection of the following pairs of graphs.

a) $y = 25 - 3x$ and $y = 3x - 17$

b) $y = 14 - x$ and $y = \frac{3}{2}x - 1$

c) $y = \frac{x}{2} - 5$ and $y = 15 - 2x$

d) $y = -4x - 8$ and $y = \frac{4}{3}x + 8$

e) $y = 3x - 4$ and $y = 28 - 5x$

f) $y = -2x - 6$ and $y = -\frac{7}{2}x - 27$

Inequalities

L.7

1) In each of the following inequalities the values of x are integers. Write down the solutions in each case.

a) $5 < x < 9$

d) $-8 < x < -5$

g) $5 < x + 1 < 9$

j) $5 < x + 3 < 9$

m) $5 < x - 1 < 9$

p) $2 < 2x < 12$

s) $2 < 2x + 1 < 9$

v) $-3 < 2x - 2 < 14$

b) $6 < x < 10$

e) $-4 < x < -1$

h) $6 < x + 1 < 10$

k) $6 < x + 6 < 10$

n) $6 < x - 3 < 10$

q) $3 < 2x < 12$

t) $3 < 2x - 1 < 13$

w) $-4 < 2x - 4 < 10$

c) $-3 < x < 1$

f) $-15 < x < -12$

i) $-3 < x + 1 < 1$

l) $-3 < x + 4 < 1$

o) $-3 < x - 3 < 1$

r) $4 < 3x < 15$

u) $-2 < 3x + 4 < 7$

x) $-6 < 3x - 2 < 3$

2) In each of the following diagrams, the information given will eliminate all the points except one. In each case write down the point.

a)

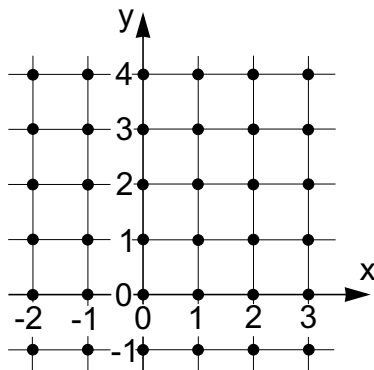

$$\begin{aligned} y &> x \\ x + y &> 4 \\ y &< 4 \end{aligned}$$

b)

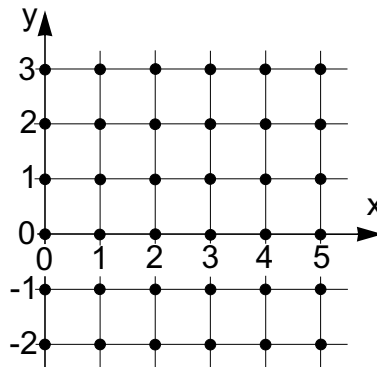

$$\begin{aligned} x + y &< 7 \\ y &> 1 \\ x &> 3 \end{aligned}$$

c)

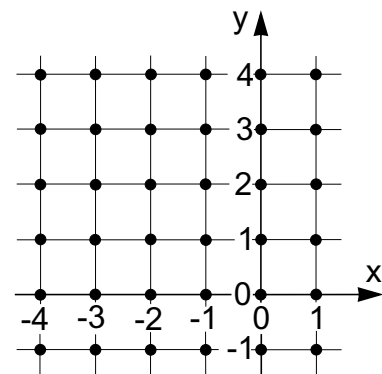

$$\begin{aligned} y - x &> 2 \\ x &> -3 \\ y &< 2 \end{aligned}$$

d)

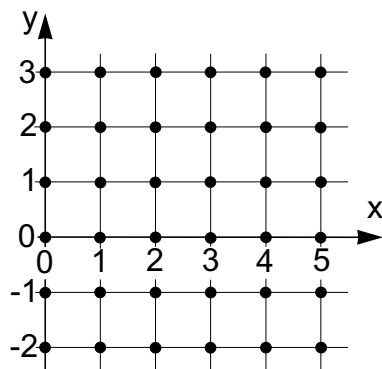

$$\begin{aligned} y - x &> -2 \\ y &< 2 \\ x + y &> 2 \end{aligned}$$

e)

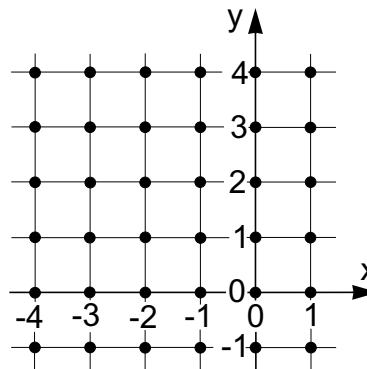

$$\begin{aligned} y &> x \\ y &< 2 \\ x &> -1 \end{aligned}$$

f)

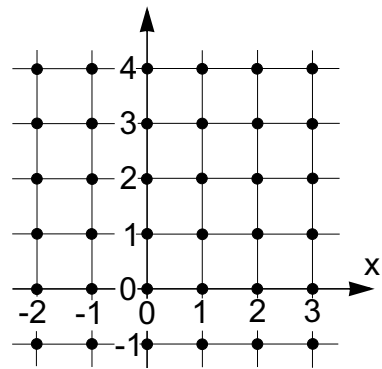

$$\begin{aligned} y - x &> 2 \\ x &> -2 \\ y &< 3 \end{aligned}$$

Pythagoras' Theorem

L.7

1) Calculate the length of the hypotenuse in each of the following right angled triangles. Give your answers correct to the nearest millimetre.

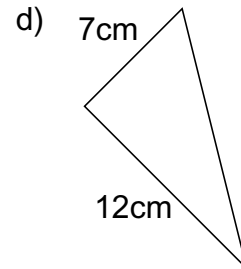
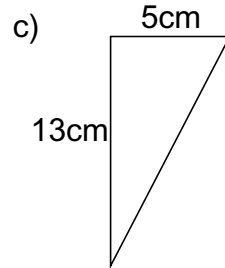
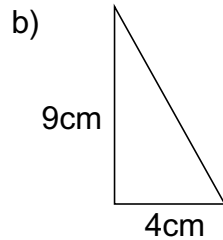
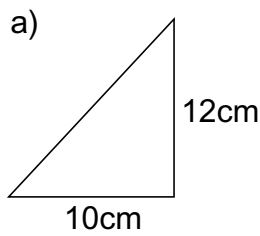

2) Calculate the length of the unknown side in each of the following right angled triangles. Give your answers correct to the nearest millimetre.

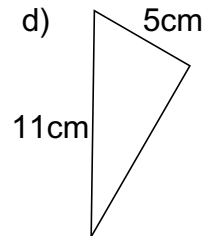
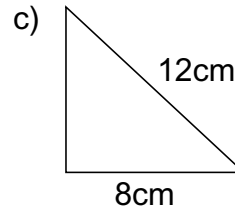
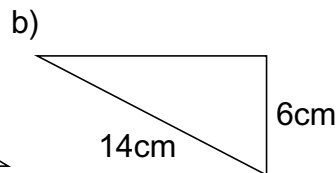
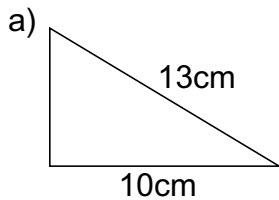

3) Explain why you know that the three triangles shown below are right angled.

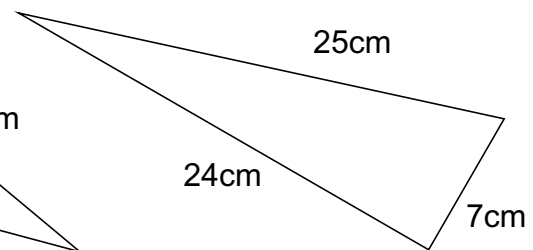
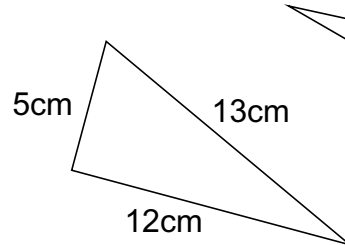
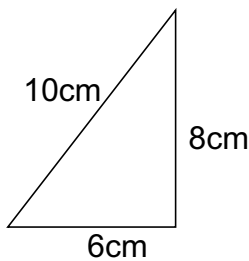

4) An isosceles triangle can be made into two congruent right angled triangles like this. What are the length of the sides of the right angled triangles?

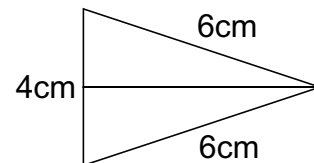

5) The diagonals of a kite cross at right angles. The shorter one is bisected, the other is cut in two. The diagonals of this kite measure 30cm and 56cm. If the smaller sides of the kite measure 25cm, what are the lengths of its larger sides?

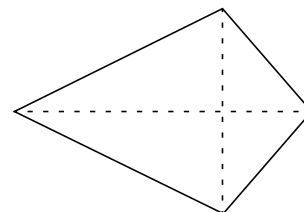

Area of a Right Angled Triangle

L.7

1) Calculate the areas of these triangles.

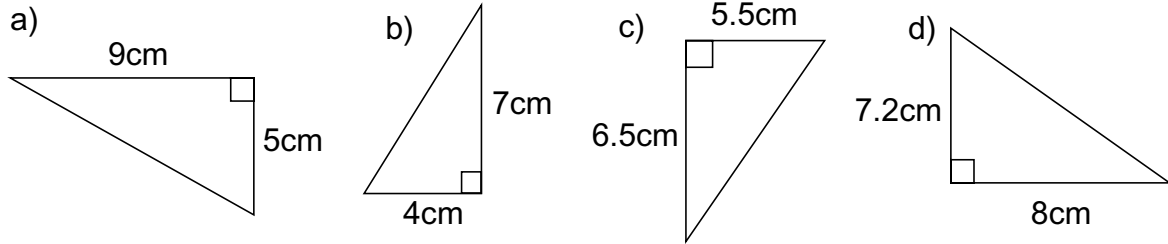

2) Calculate the areas of these triangles.

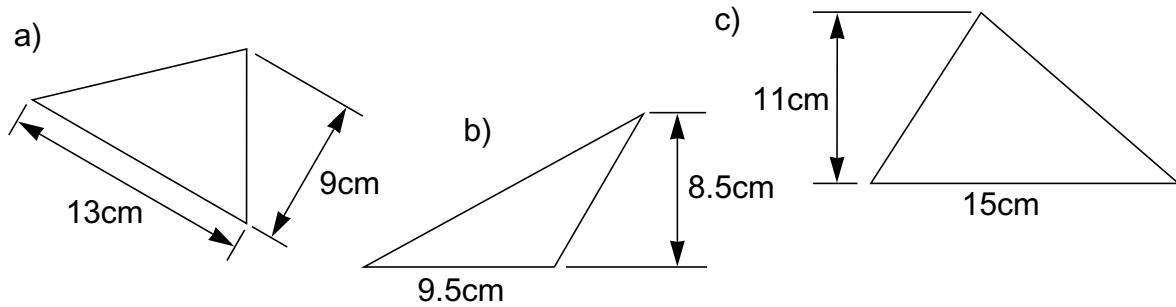

3) Use the rule for finding the area of a triangle to calculate the shaded areas in the following shapes. Diagram b is a kite, c is a rhombus and d is a parallelogram.

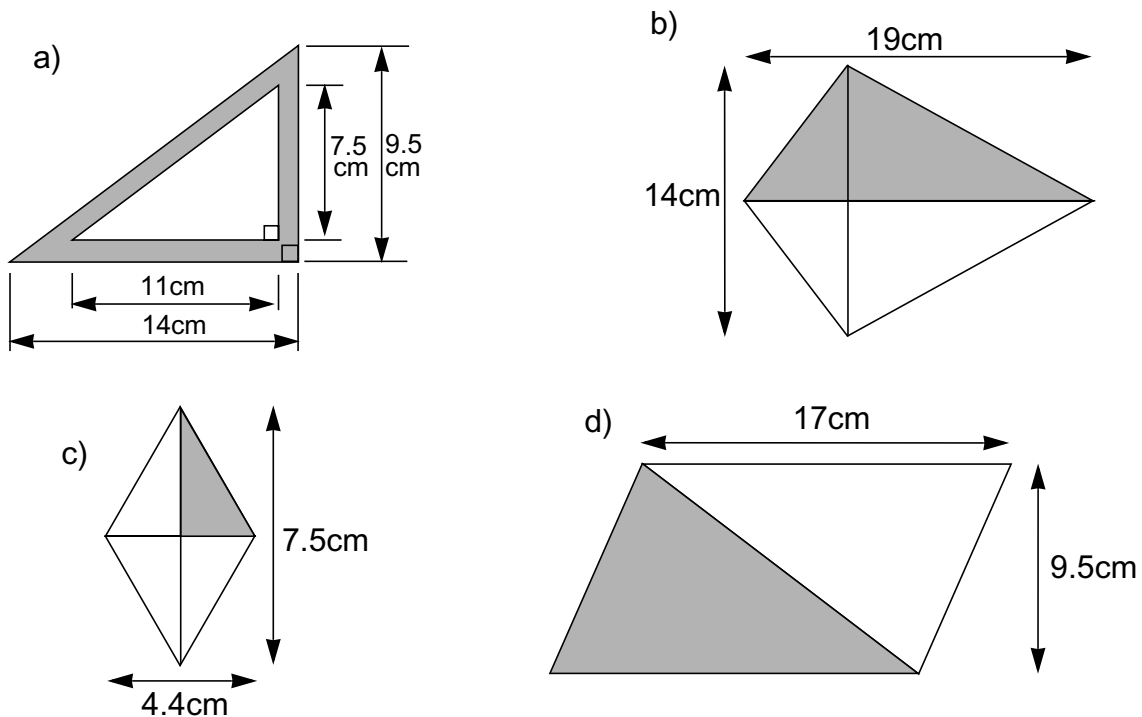

4) Using the results of question 3, explain how you would calculate the areas of:-

- a) a kite
- b) a rhombus
- c) a parallelogram

Areas of Plane Shapes

L.7

1) Calculate the areas of the trapezium, parallelogram, kite and rhombus shown below.

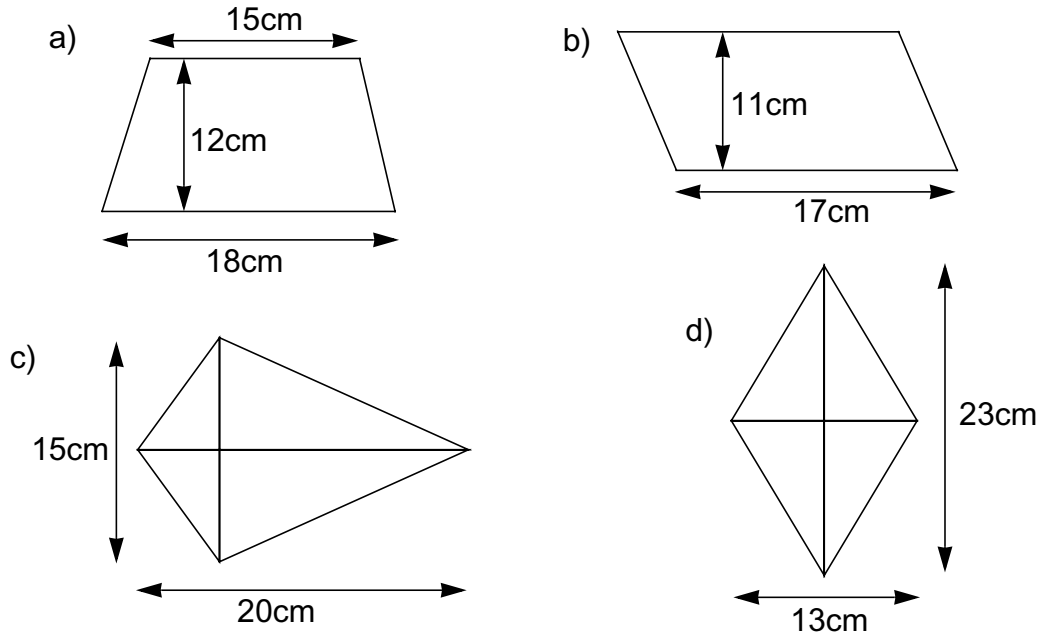

2) Calculate the areas of the shaded parts of these shapes.

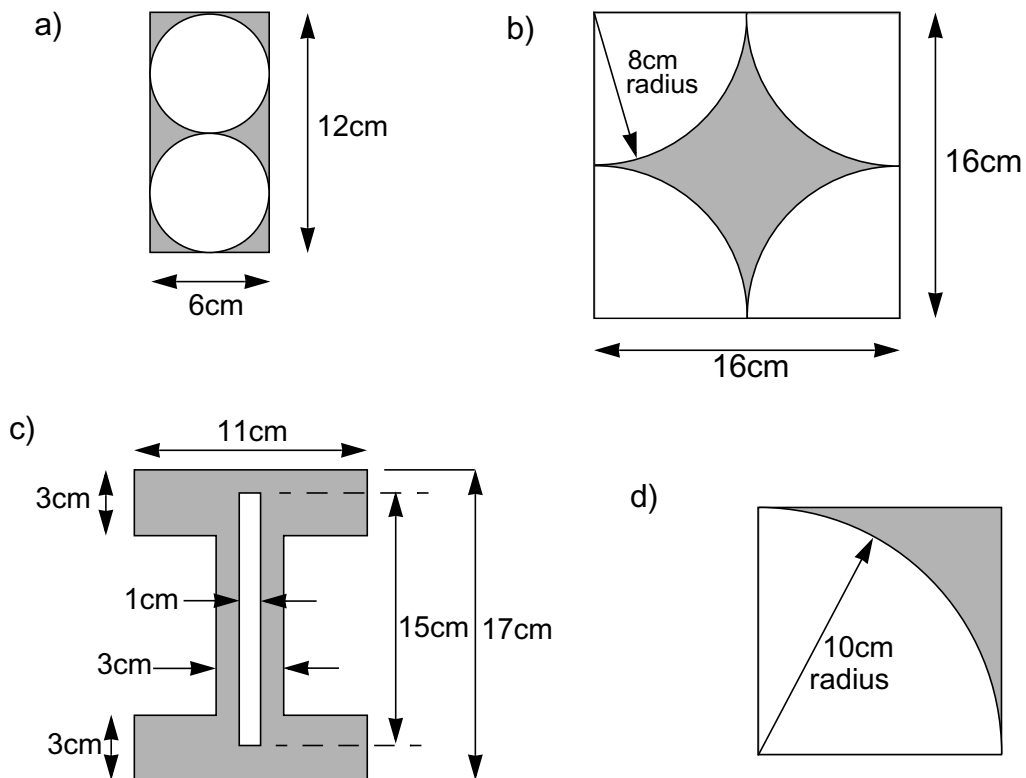

Volumes of Prisms

L.7

1)

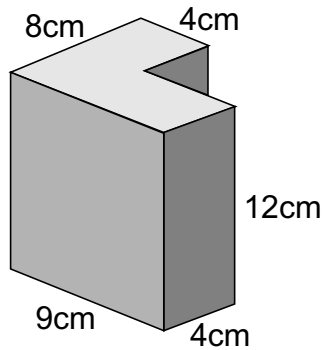

The diagram on the left shows a prism of height 12cm

- a) Calculate the area of its top.
- b) What is its volume?

2)

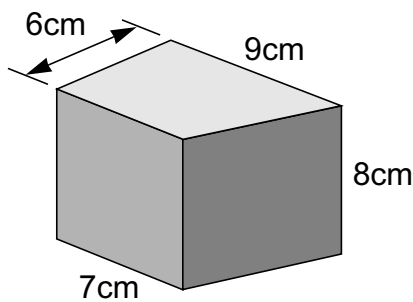

The diagram on the left shows a trapezoidal prism of height 8cm.

- a) Calculate the area of its top.
- b) What is its volume?

3)

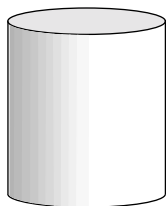

Calculate the volume of the cylinder on the left which has a diameter of 7cm and a height of 9cm.

4)

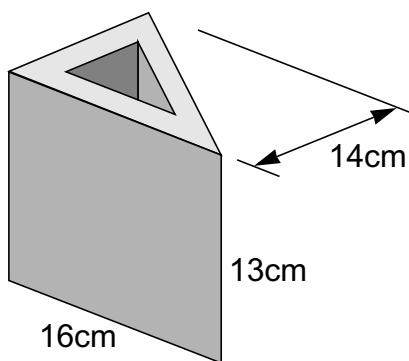

The prism on the left is 13cm in height. Its top is in the shape of a triangle with a smaller similar triangle cut from it. The height of the larger triangle is 14cm and that of the smaller one is 7cm.

- a) What is the area of its top?
- b) Calculate the volume of the solid part.

5)

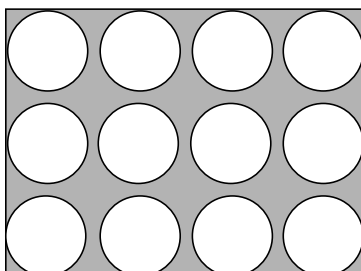

Drinking glasses of diameter 6cm and depth 12cm are packed into boxes with internal measurements of 28.5cm long, 19cm wide and 13cm high. The spaces between and around the glasses are filled with polystyrene granules. Calculate the volume the polystyrene has to fill.

Enlargement and Similarity

L.7

- 1) The diagram below shows two similar right angled triangles. Triangle A has been enlarged by a factor of $1\frac{1}{2}$ to make triangle B.

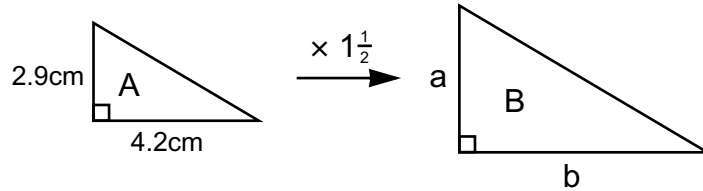

- a) What are the dimensions of sides a and b?
- b) What are the areas of triangles A and B?
- c) Complete this ratio:-

$$\begin{array}{l} \text{Area of triangle A} : \text{Area of triangle B} \\ 1 : \dots \end{array}$$

- 2) The diagram below shows two similar triangles, one an enlargement of the other.

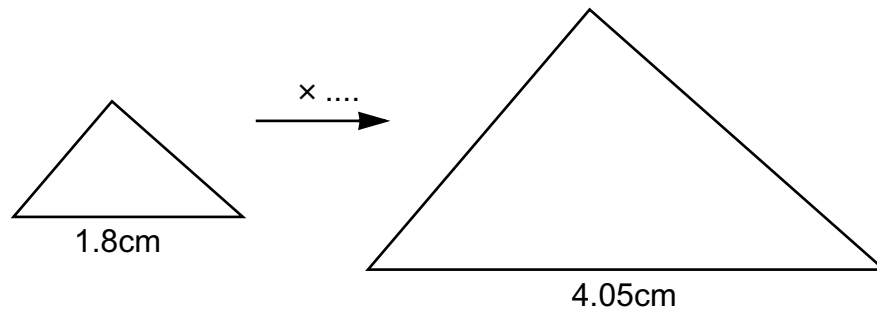

- a) What is the scale factor of the smaller one to the larger one?
- b) What is the scale factor of the larger one to the smaller one? (give your answer as a fraction)

If the area of the smaller triangle is 1.08cm^2

- c) What is its height?
- d) What is the area of the larger triangle?

- 3) The diagram shows two similar shapes.

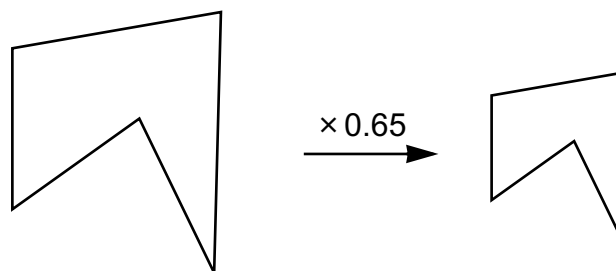

The dimensions of the larger shape have been multiplied by 0.65 to get those of the smaller shape.

- a) One of the dimensions on the larger shape is 4.2cm. What is the size of the corresponding dimension on the smaller shape?
- b) One of the dimensions on the smaller shape is 2.34cm. What is the corresponding dimension on the larger shape?
- c) If the area of the larger shape is 10cm^2 , what is the area of the smaller one?

Routes

L.7

1) The diagram below shows a field measuring 120 metres by 80 metres.

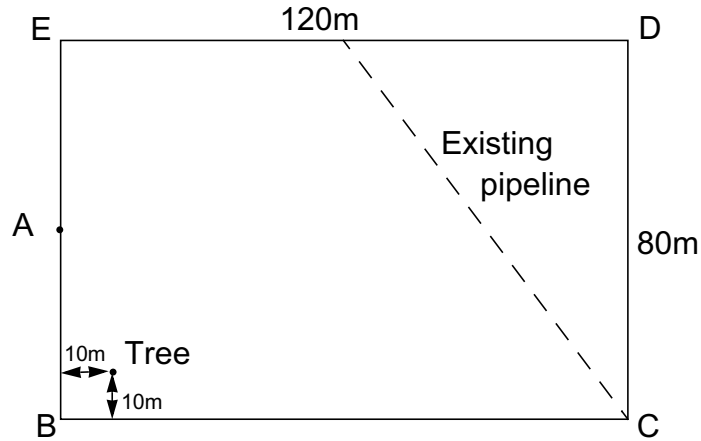

It has a tree growing near to corner B, 10m from each of the two sides. An existing pipeline enters the field at the mid point of side ED and leaves the field at corner C. It is proposed to run another straight pipeline from point A, half way along side EB to side BC. The pipeline must not be within 10 metres of the tree or 15 metres of the existing pipeline.

Make an accurate scale drawing of the field, using a scale of 1cm to represent 10 metres.

On your diagram shade in the area through which the pipe can run.

2) The diagram shows part of a lake. There are three danger markers, A, B and C on the lake and it is recommended that boats should keep well clear of them.

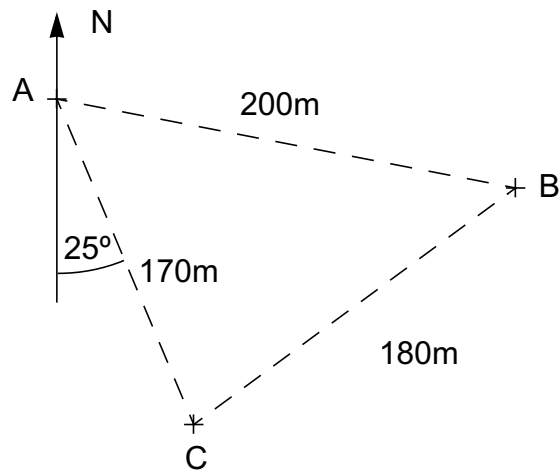

A boat travels between markers A and C then alters course to go between A and B.

- Draw an accurate diagram of the relative positions of the markers, using a scale of 1cm to represent 20 metres.
- The boat travels so that it is equidistant from A and C, then it alters course so that it is equidistant from A and B. Draw accurately on your diagram the route of the boat.

Trees

L.7

- 1) The diagram below shows the plan of a garden in the shape of a rectangle measuring 12 metres by 14 metres.

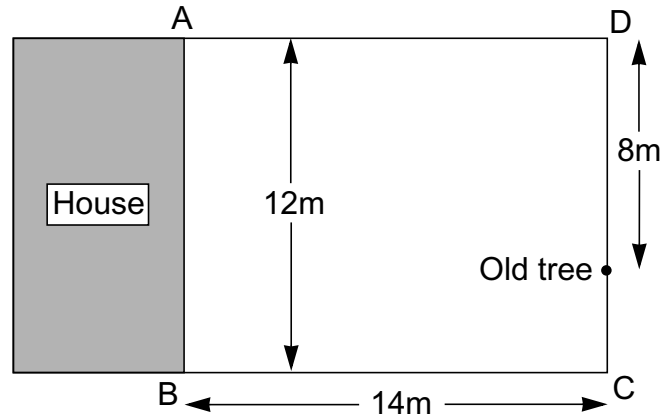

A tree is growing on the boundary DC, 4 metres from the corner C. A new tree is to be planted. It must not be within 4 metres of the old tree. It is to be equidistant from sides DC and BC and it must not be within 4 metres of the house.

- a) Draw an accurate diagram of the garden using a scale of 1cm to represent 1m.
 d) Clearly indicate on the diagram where the tree can be planted.
- 2) The diagram shows a plan of a small public garden next to a canal. There are two trees, 20 metres apart and both 8 metres from the canal.

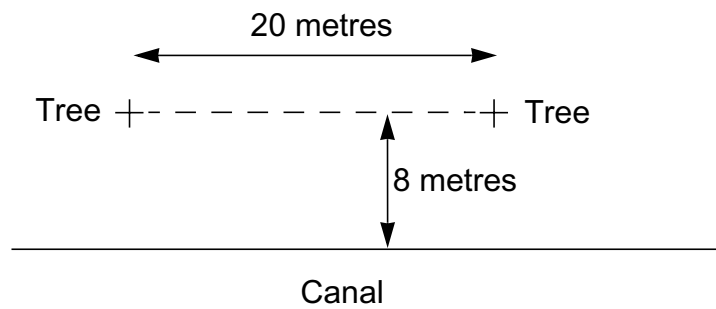

A bench is to be placed in the garden. It must be within 12 metres of each of the trees but further than 4 metres from the canal.

- a) Draw an accurate sketch of the garden, using a scale of 1cm to represent 2 m.
 b) Clearly indicate on the diagram the area where the bench can be placed.

Rounding Off

L.7

- 1) What are the distances marked on the number line, correct to the nearest whole number?

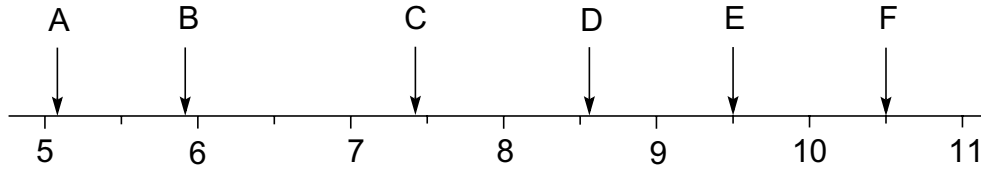

- 2) This rectangle has dimensions measured correct to the nearest cm.

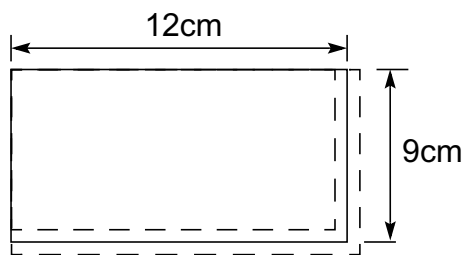

- Calculate the minimum area of the rectangle.
- Calculate the maximum area of the rectangle.

- 3) The diagram below shows the plan of a running track. It is made up of two straight lengths of 100m and two semicircles of 60m diameter. The dimensions are given correct to the nearest metre.

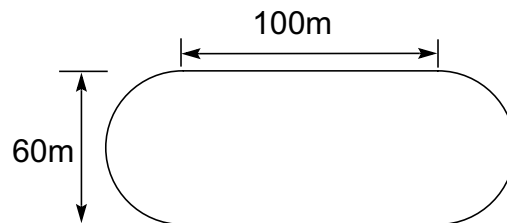

What is the minimum distance around the track?

- 4) The length of a piece of wood is given as 137cm correct to the nearest cm. Complete this statement:-

$$\dots \leq \text{Length of wood} < \dots$$

Explain why the signs \leq and $<$ are used.

- 5) The daily temperatures given by the Weather Bureau are always rounded to the nearest degree celsius. What are the maximum and minimum values of a temperature of 20°C ?
- 6) Five people get into a lift. The lift will not move if their combined mass is greater than 500kg. The masses of the 5 people are 105kg, 95kg, 89kg, 109kg and 101kg, all measured to the nearest kilogram. Explain why the lift refuses to move.

Imprecision of Measurement

L.7

- 1) Boxes and their lids are made to these dimensions, correct to the nearest mm.

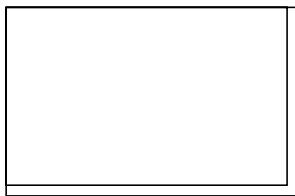
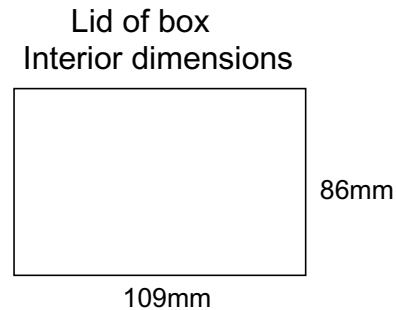
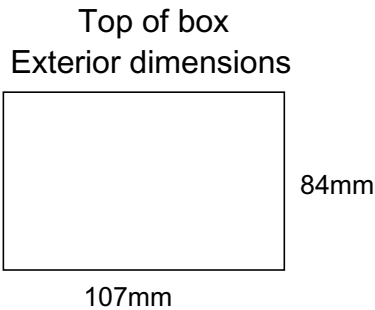

When the lid is put on the box there is a gap between them, as shown on the left.

- a) What is the maximum gap between lid and box?
- b) What is the minimum gap between lid and box?

- 2) The timetable says that the buses arrive at the bus stop every 10 minutes, at 8:00, 8:10, 8:20, 8:30 and so on. The bus company says that they are always on time to the nearest minute.

Jan arrives at the bus stop just as a bus is leaving.

- a) What is the maximum time she will have to wait for the next bus?
 - b) What is the minimum time she will have to wait for the next bus?
- 3) At an athletics meeting, the javelin throws are measured to the nearest centimetre. The winning throw was 37.31 metres, equalling the record. Explain why this throw could have been the new record.
- 4) At the same athletics meeting the 400 metres relay race was won in a time of 58.3 seconds, correct to the nearest $\frac{1}{10}$ th of a second. Between what two values does the actual time lie?
- 5) Water tanks are made in the shape of open cuboids. They are made 94cm tall, 100cm wide and 112cm long. Each dimension is measured to the nearest centimetre.

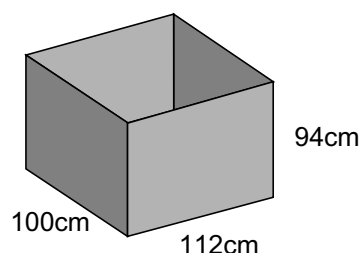

The makers advertise them as capable of holding up to 1068 litres.

Is this a good estimate?

Explain your answer.

Compound Measure

L.7

- 1) A small car has an average fuel consumption of 48 miles per gallon. A large car has a fuel consumption of 23 miles per gallon.
 Jaspal calculates that he travels 9,500 miles each year.
- How many gallons of petrol would he use in a year if he bought the small car?
 - How many gallons of petrol would he use in a year if he bought the large car?
 - A third car is medium sized and the fuel consumption is 10 kilometres per litre. How many gallons of petrol would he use in a year if he bought this car?
- 2) The outside walls of a house are to be painted. The plan of the house is a rectangle measuring 13 metres by 10 metres. The walls are 5 metres tall.

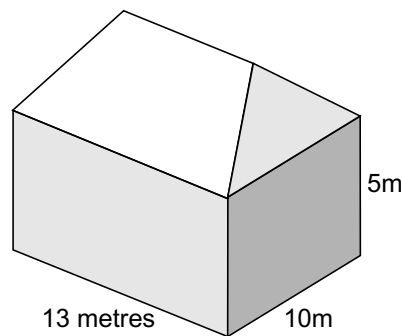

- Calculate the total area of the four walls.
 The house has 12 windows in it and 2 doors. Four of the windows measure 130cm by 250cm and six others measure 130cm by 150cm. The remaining two windows measure 130cm by 60cm. The doors measure 90cm by 2m.
 - Calculate the total area of the windows and doors in m^2 .
 - What is the total area of wall needing to be painted?
 - Paint is bought in cans containing 10 litres and 1 litre is sufficient to cover 8.5m^2 . How many cans of paint are needed?
- 3) The distance from the bus terminus to Ama's house is 3.5 kilometres. The journey takes 8 minutes. Calculate the average speed of the bus in kilometres per hour.
- 4) The velocity of sound through air is approximately 760 miles per hour. If the noise of thunder takes 8 seconds to reach the listener approximately how far away will it be in metres?
- 5) A hosepipe feeds water into a tank of height 2 metres and internal diameter of 1.6m.
- Calculate the volume of water in the tank when it is full.
 The hosepipe has an internal diameter of 2.5cm.
 - Calculate the volume of 1 metre of water in the pipe.
 The tank takes 30 minutes to fill up.
 - How much water enters the tank in 1 second?
 - Calculate the speed of the water in the pipe in metres per second.

Currency

L.7

- 1) Donna goes to Florida on a holiday. She takes 600 dollars with her to spend. She buys this money at a rate of \$1.37 for £1.00. Calculate how much it costs, to the nearest penny.
She buys the money from a travel agent who adds on another 2.5% commission. What is her total bill?

- 2) On the back of a book the price is written in three ways.

£5.99 in UK
 \$7.99 in USA
 \$14.99 in Australia.

 If the rate of exchange is 1.37 US dollars to a pound and 2.67 Australian dollars to a pound, in which country will the book cost most and in which will it cost least?

- 3) Dan travels to Canada for a holiday. He changes £400 into Canadian dollars before he goes at a rate of \$2.11 for £1.00. He spends a week in Vancouver then travels on to the USA. He decides to change 200 of his Canadian dollars into American dollars. He knows that in the UK he can get 1.37 American dollars for £1.00. How many US dollars does he expect to get?

- 4) The exchange rate between the UK pound and the Turkish lira is £1.00 equals 1,877 lira.
Donna goes on a holiday to Turkey. How many lira can she buy for £250?
When Donna gets to Turkey she finds that the exchange rate has changed to 1,936 lira to a pound. How many more lira could she have gained if she had changed her money in Turkey?

- 5) The car Mrs Lee wants to buy costs £7,890 in her town. She finds that in Europe the same car costs 9,400 euros. If 1 euro is worth 66p, how much money does Mrs Lee save by buying it in Europe?

- 6) Rik wants to go on a travelling holiday to New Zealand. It costs £450 to travel from the UK to New Zealand or £790 return. However, he is told that the one way fare from New Zealand back to the UK is \$1000. If £1.00 buys 3.29 New Zealand dollars, is it more economical to buy a return fare or two one way fares?

- 7) In 2001 Erol bought a pair of sandals in Portugal for 5,500 escudos. On the bottom of his receipt it says '205 escudos = 1 euro'. Erol knows that 1 euro is worth 69p. What is the cost of his shoes in pounds?

Coach Journey

L.7

The simplified graph shows the journey a coach makes between Manchester and London.

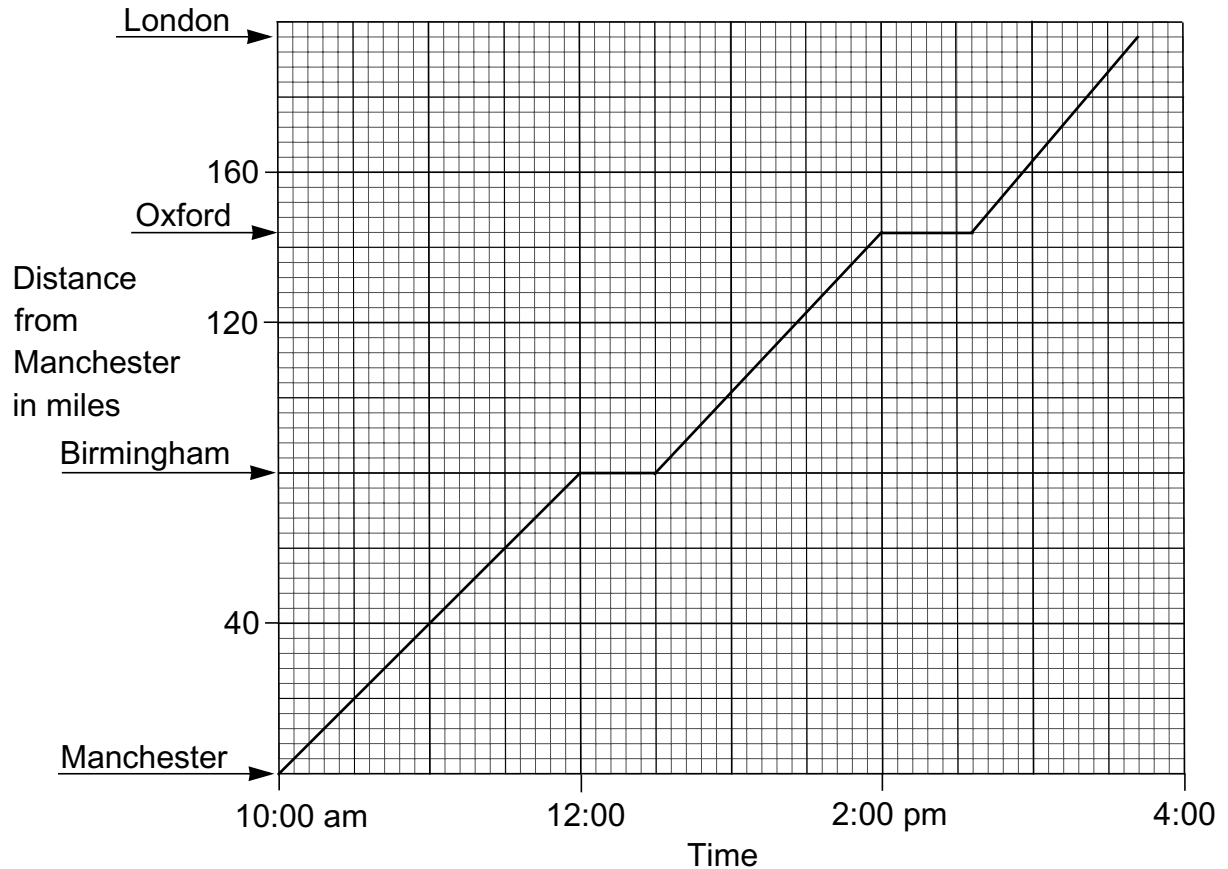

- What distance does the coach travel between Manchester and Birmingham?
- What is the average speed of the coach between Manchester and Birmingham?
- For how long does the coach stop in Birmingham?
- What is the distance travelled by the coach between Birmingham and Oxford?
- What is the average speed of the coach between Birmingham and Oxford?
- For how long does the coach stop in Oxford?
- At what time does the coach leave Oxford?
- What is the distance between Oxford and London?
- What is the average speed of the coach between Oxford and London?
- At what time does the coach arrive in London?

Train Journey

L.7

Mair takes a train journey to Glasgow from Cardiff. She has to change trains at Birmingham. Below is shown a simplified graph of her journey.

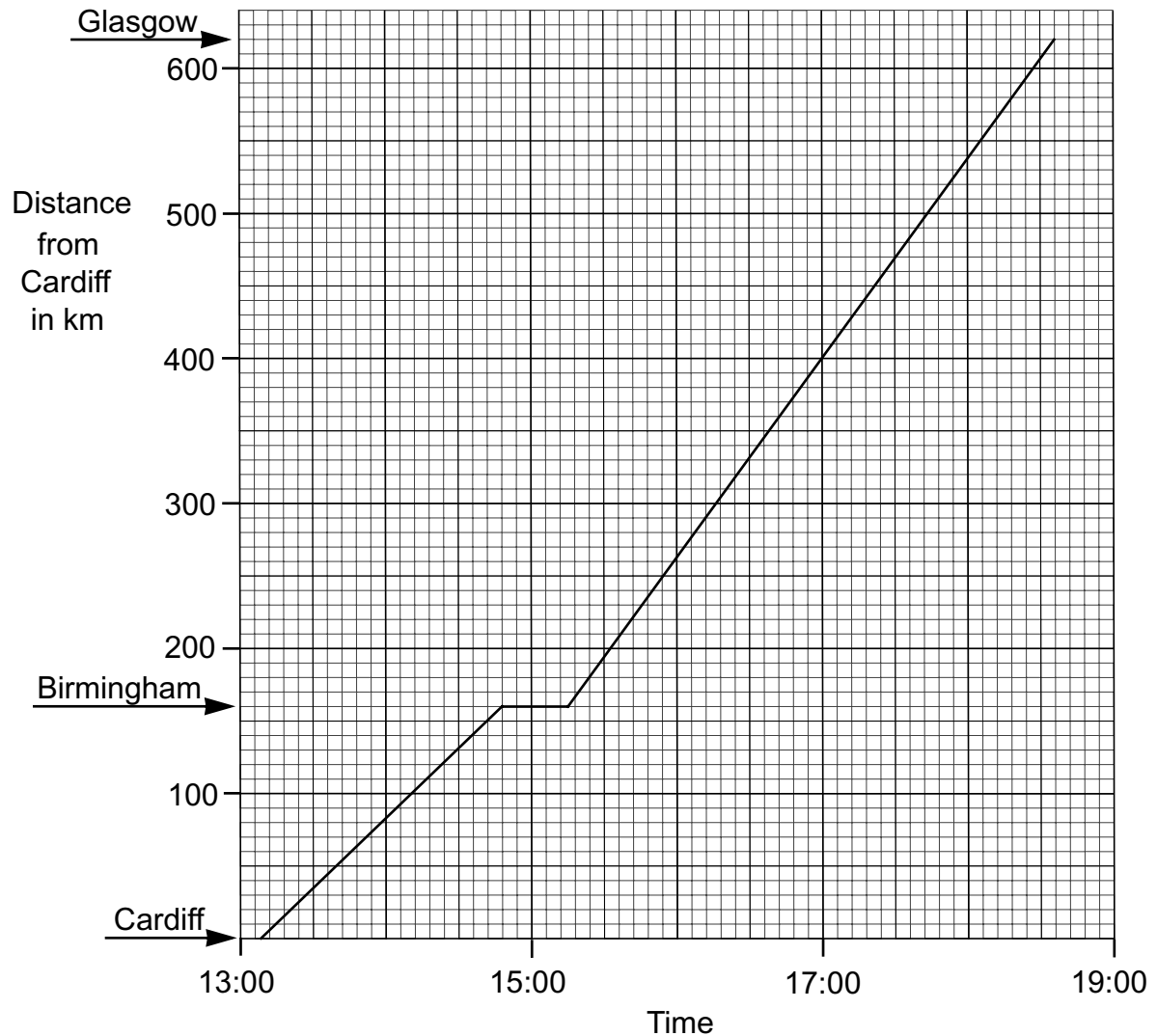

- Without calculating, say over which part of her journey the train travelled at the greatest speed.
- What were the average speeds over the two parts of the journey?
- What is the distance from Birmingham to Glasgow?
- What was the total time for her journey?
- How long did she have to wait at Birmingham station?
- Another train leaves Glasgow for Birmingham at 14:27. It arrives at Birmingham at 17:12. At approximately what time do the trains pass?
- How far from Glasgow is Mair when the two trains pass?

Road Race

L.7

Two friends, Brody and Hari run a 20 kilometre race from Ambridge to Blaconsfield and back. The diagram below shows a rough sketch of their journeys.

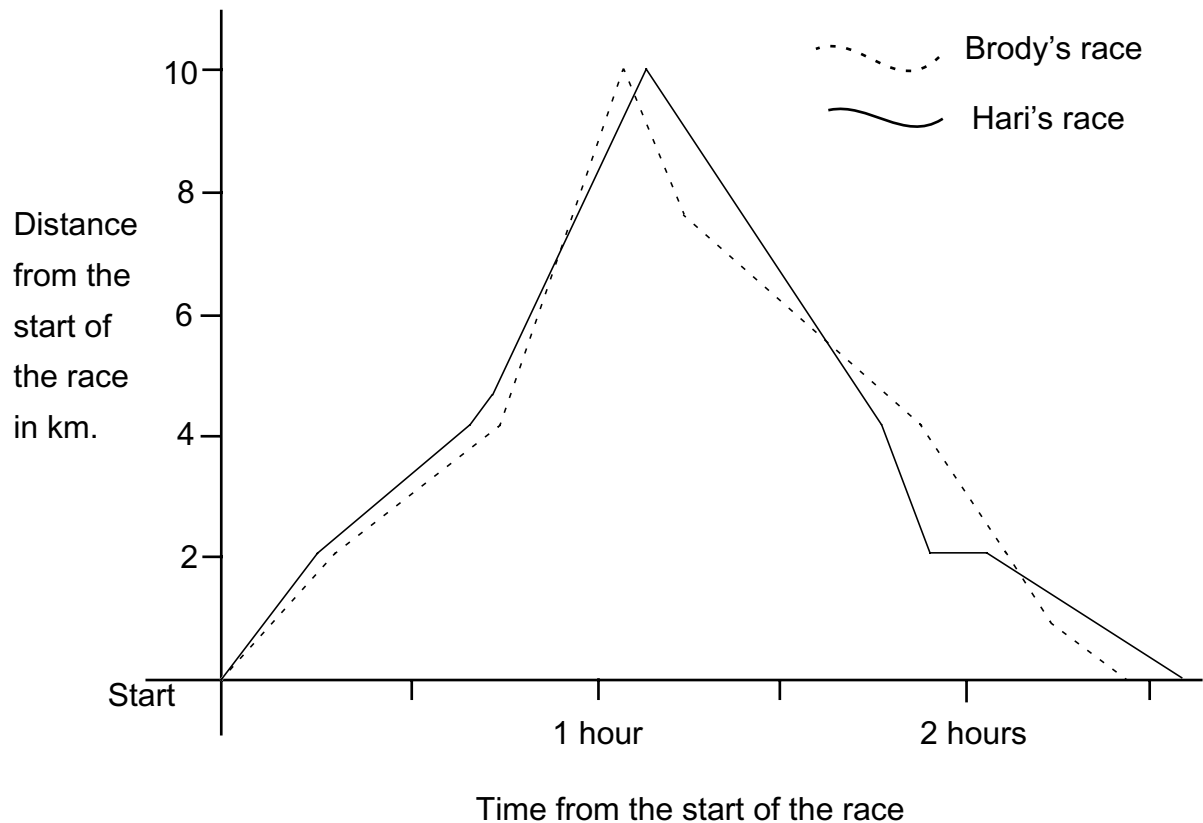

- Which of the two friends first takes the lead?
- Along the journey they encounter a hill. Approximately how far from Ambridge is the beginning of the hill?
- At what time did the lead first change?
- How many times did they pass each other?
- How many times did the lead change?
- Who was in the lead at the 1 hour point?
- Who was running the fastest just after the half way point?
- Why did their speed increase between the 1hr 45min and 2hr points?
- Who won the race and by what time interval?
- What was Brody's approximate average speed for the whole race?
- Give an explanation of the dramatic events at the 18km point.

Mean

L.7

- 1) Joe grows plants in his greenhouse. After one week he measures the heights of them. These are the results he gets, correct to the nearest cm.

Height of plant cms	Number of plants
45	5
46	8
47	19
48	23
49	12
50	3

- Calculate the mean height of the plants, correct to the nearest millimetre.
- What is the modal height of the plants?
- What is the median height of the plants?
- What is the range of their heights?

- 2) The table below shows the sales of two books in 50 stores throughout the country.

Number of books sold	Number of shops selling book A	Number of shops selling book B
0	3	7
1	10	6
2	7	5
3	7	5
4	8	7
5	7	5
6	4	6
7	1	5
8	0	2
9	3	2

For example, 3 shops sold no book A's and 7 shops sold no book B's.

- For each of the two books, calculate the mean number sold at the stores.
- For each book, how many shops sold less than the mean?

These stores are part of a larger group of 210 stores.

- For each book, calculate the approximate number of books the company sold in all its stores.

Mean and Range

L.7

- 1) The mean and range of these numbers are equal. What is the value of the missing number?

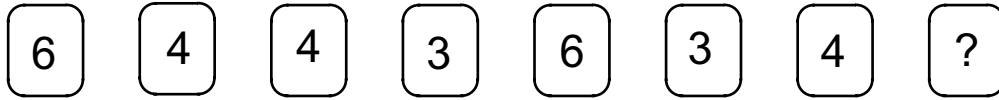

- 2) The ages of 8 children are shown below. If the mean is 7 what is the range?

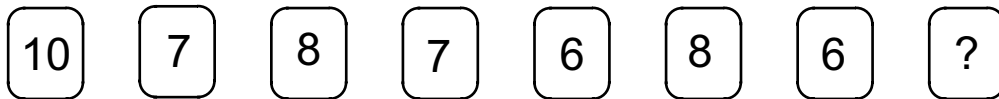

- 3) Card number 8 will increase the mean of these numbers by 2. What number is on the new card?



- 4) The mean of these 8 numbers is 9 and their range is 8. What are the two missing numbers?



- 5) The mean of these 8 numbers is 4 and their range is 4. What are the two missing numbers?



- 6) The ages of 8 children are shown below. If the mean and range are equal and all are below 10, what are the missing ages?



- 7) The cards below have 8 numbers on them. The mean and range of these numbers are equal. What are the missing card numbers if they are equal to each other?



Sweets

L.7

A company make packets of coloured sweets. They counted the number of red and yellow sweets in 50 packets. The results are shown in the diagram below.

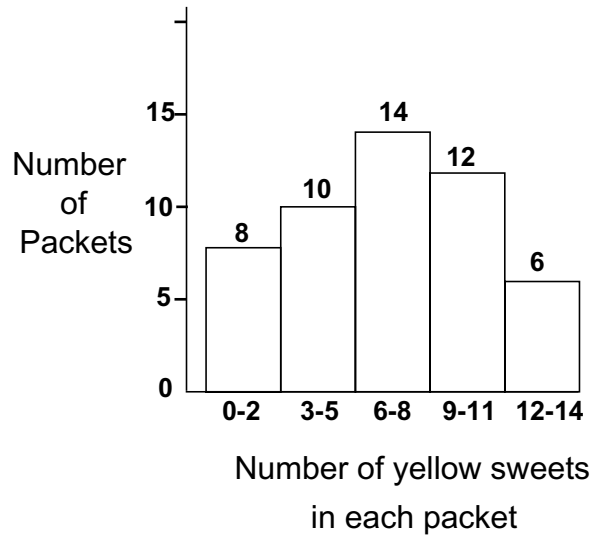
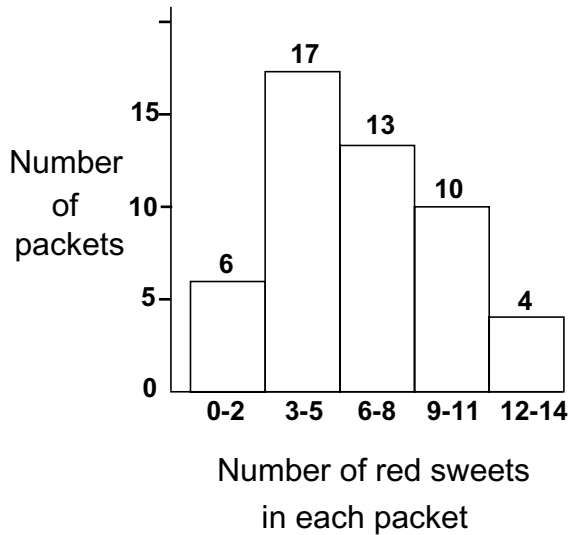

- a) Complete the table below. Use it to estimate the mean number of red sweets in a packet.

Number of red sweets	Mid point of bar (x)	Number of packets (f)	xf
0-2	1	6	6
3-5	4	17	68
6-8	7	13	
9-11	10	10	
12-14	13	4	
		50	

- b) Draw a similar table and estimate the mean number of yellow sweets in a packet.
- c) Each day the company produces 1,000 packets of sweets. Approximately how many red and yellow sweets does it make?
- d) Approximately how many packets contain 10 or less red sweets?

Flower Seeds

L.7

A company produce packets of seeds that will grow into a mixture of blue and white flowers. 100 packets were sown and the resulting colour of the flowers were recorded. The table below shows the results.

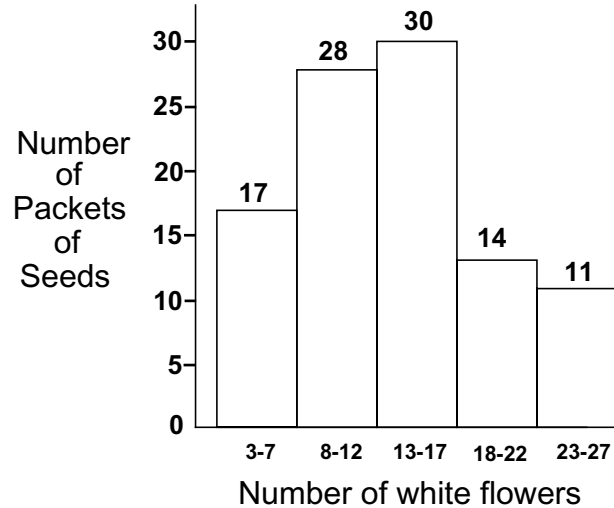
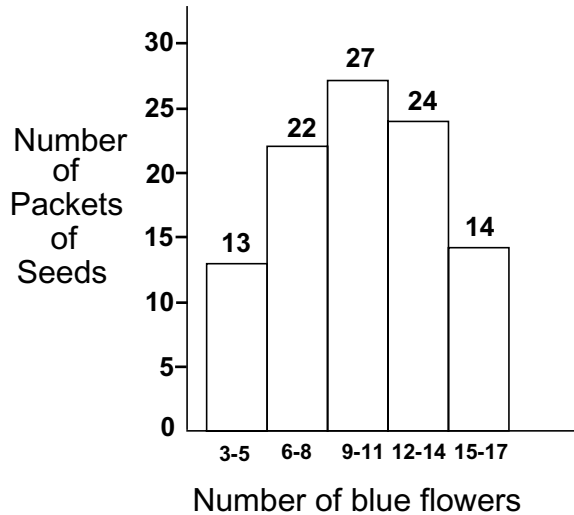

a) Complete the table below and estimate the mean number of blue flowers a packet of seeds will produce.

Number of blue flowers	Mid point of bar (x)	Number of packets (f)	xf
3-5	4	13	52
6-8	7	22	
9-11	10		
12-14			
15-17			

- b) Draw a similar table and estimate the mean number of white flowers a packet of seeds will produce.
- c) Each year the company produces 15,000 packets of these seeds. Approximately how many blue and white flowers will the packets produce?
- d) Approximately how many packets produce more than 14 white flowers?
- e) Which of the two charts shows a greater range? Explain your answer.
- f) Fill in the blanks in this sentence 'A packet of seeds usually has more seeds in it than seeds'.

Measuring Scatter

L.7

- 1) At The Castle Cafe they sell soup to their lunchtime customers. The scatter diagram below shows the number of bowls sold in May plotted against the lunchtime outdoor temperatures.

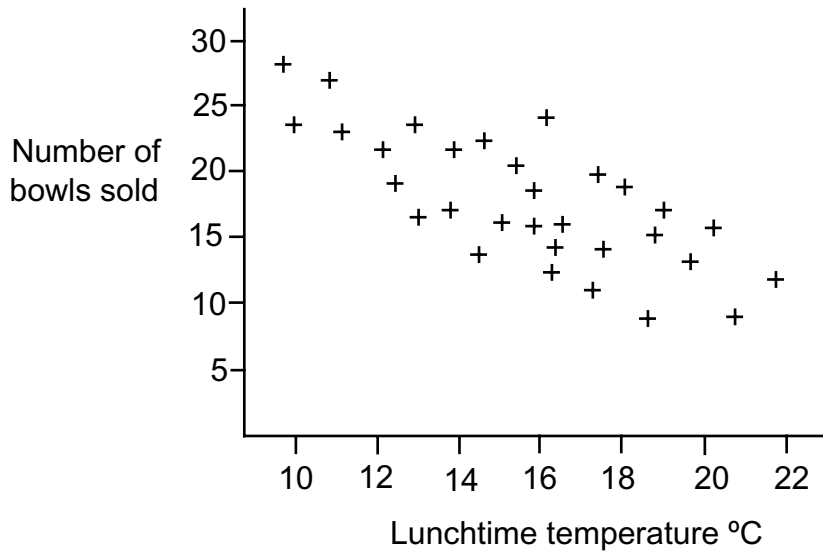

- Draw in a line of best fit.
 - How many bowls of soup would you expect to sell when the temperature is 19°C?
 - Would you expect to sell more or less soup in January?
- 2) A spring is hung from a hook and masses attached to it. The length of the spring is measured each time a mass is attached to it. The results are then plotted. These are shown below.

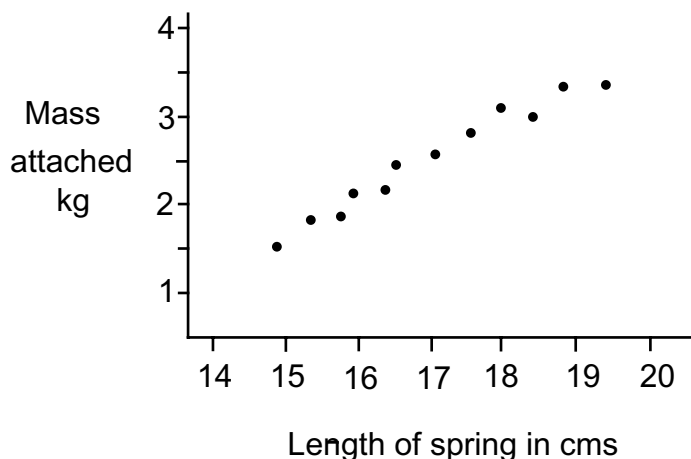

- Draw a line of best fit.
- An object is hung on the bottom of the spring. The length of the spring increases to 17.5cm. What is the mass of the object?
- An object has a mass of 2.2kg. What will be the approximate length of the spring?

Relative Frequency

L.7

- 1) A die is rolled 100 times and the number of sixes recorded. How many times would you expect the 6 to occur?
- 2) A bag contains 9 discs, all similar to the touch. Some of the discs are blue, some are green and some are red. Abi takes a disc from the bag and records the colour. She then replaces the disc. She does this 100 times recording all the results in the table below.

Blue	Green	Red
45	34	21

How many discs of each colour do you think are in the bag?

- 3) A small cube has 2 red sides, two blue sides and 2 yellow sides.

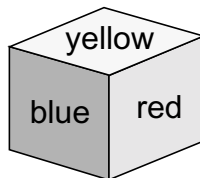

Some friends do an experiment to decide whether this cube is biased. They each roll the cube and record the colour of the top face. These are the results they get.

Name	Number of Throws	Results		
		Red	Blue	Yellow
Emma	100	45	34	21
Liam	160	87	40	33
Harriet	60	28	23	9
Jude	80	46	20	14

- a) Whose data are more likely to give the most accurate estimate of the probability of getting each result? Explain your answer.
- b) Is the cube biased? Explain your answer.

The friends combine their results.

Number of Throws	Results		
	Red	Blue	Yellow
400	206	117	77

- c) Use these results to calculate the probability of getting a yellow.
- d) Use these results to calculate the probability of getting a red.

Probability

L.7

- 1) Euan plays chess against his friend Joy. Over the last month he has won 8 times. He says that his chance of winning the next game is 0.4.
- What is his chance of not winning?
 - How many games have they played altogether?
 - If Joy's chance of winning is 0.5 how many games did they draw?
- 2) Two bags contain red, yellow and blue cubes. All the cubes are the same to the touch.

Bag A contains
12 red
16 yellow and
22 blue cubes

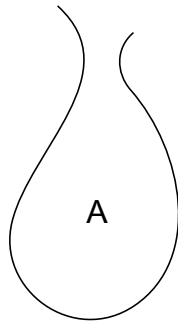

Bag B contains
11 red
14 yellow and
20 blue cubes

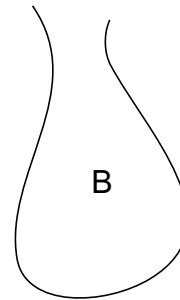

Tariq takes a cube from one of the bags.
He wants to choose a yellow cube.
Which bag should he choose? Explain your answer.

- 3) Bello plays cricket for his school team. Last season they won 5 games, lost 7 and drew 4.
- What was his team's chance of winning a game last year?
He says that this year they have a better chance of winning. He estimates that they should have at least a 40% chance of winning their matches.
 - If they play the same number of matches this season, how many would you expect Bello's team to win?
- c) Half way through the season Bello's team has won 4 games, lost 1 and drawn 3. He adds these values to last years results and calculates a new probability of the team winning.

Results		
Win	Lose	Draw
9	8	7

What did Bello calculate the new probability to be?

- d) Bello uses this value to estimate the number of matches he will win in the second half of the season. What value did Bello get?

Powers

Do not use a calculator

L.8

1) This table shows the powers of 4

$$\begin{aligned}
 4^0 &= 1 \\
 4^1 &= 4 \\
 4^2 &= 16 \\
 4^3 &= 64 \\
 4^4 &= 256 \\
 4^5 &= 1024 \\
 4^6 &= 4096 \\
 4^7 &= 16384 \\
 4^8 &= 65536 \\
 4^9 &= 262144 \\
 4^{10} &= 1048576 \\
 4^{11} &= 4194304 \\
 4^{12} &= 16777216
 \end{aligned}$$

- Explain how the table shows that $256 \times 1024 = 262144$
- Explain how the table shows that $64 \times 262144 = 16777216$
- Explain how the table shows that $1048576 \div 16384 = 64$
- Explain how the table shows that $16777216 \div 1048576 = 16$
- Use the table to work out $\frac{4194304}{16384}$
- Use the table to work out $\frac{16777216}{1048576}$

2) $8^6 = 262144$. Use this information to write down the following.

- What is the units digit of 8^{12} ?
- What is the units digit of 18^{12} ?
- What could the units digit of 8^3 be?
- What could the units digit of 18^3 be?

3) Which of the following are true? Give the correct answer when they are not, or explain why.

- | | | |
|------------------------------|-------------------------------------|------------------------------|
| a) $12^1 \div 6^0 = 6^1$ | b) $2^{10} \div 4^5 = 1$ | c) $3^9 \times 3^2 = 6^{18}$ |
| d) $7^6 \times 7^3 = 7^9$ | e) $16^4 \div 8^2 = 8^2$ | f) $4^2 \times 2^4 = 8^6$ |
| g) $2^7 \times 3^3 = 6^{10}$ | h) $4^{10} \div 2^4 = 4^8$ | i) $8^6 \div 8^1 = 8^6$ |
| j) $12^3 \div 6^3 = 2^3$ | k) $3^{12} \times 3^{12} = 3^{144}$ | l) $8^0 \times 8^0 = 0$ |

Standard Form 1

Do not use a calculator

L.8

1) Write down these numbers in standard form.

- | | | | |
|--------------|----------|---------------|--------------|
| a) 1563 | b) 2,573 | c) 72,835 | d) 834,000 |
| e) 54,000 | f) 3,400 | g) 43,800,000 | h) 243,850 |
| i) 2,460,000 | j) 243 | k) 3,490,000 | l) 6,700,000 |

2) Write down these numbers in standard form.

- | | | | |
|----------------|--------------|-------------|---------------|
| a) 0.0045 | b) 0.0000463 | c) 0.000432 | d) 0.0000351 |
| e) 0.0035 | f) 0.038 | g) 0.000431 | h) 0.00000739 |
| i) 0.000000342 | j) 0.000629 | k) 0.000273 | l) 0.3 |

3) Change these numbers from standard form.

- | | | | |
|-----------------------|-----------------------|-----------------------|-----------------------|
| a) 3.5×10^3 | b) 4.2×10^5 | c) 1.8×10^4 | d) 6.5×10^3 |
| e) 4.61×10^4 | f) 6.72×10^7 | g) 4.58×10^6 | h) 7.4×10^2 |
| i) 2.67×10^5 | j) 5.68×10^3 | k) 4.83×10^6 | l) 2.65×10^4 |

4) Change these numbers from standard form.

- | | | | |
|--------------------------|--------------------------|--------------------------|--------------------------|
| a) 4.3×10^{-2} | b) 5.37×10^{-4} | c) 2.85×10^{-1} | d) 5.9×10^{-4} |
| e) 6.34×10^{-5} | f) 5.9×10^{-3} | g) 8.45×10^{-4} | h) 6.91×10^{-2} |
| i) 6.8×10^{-3} | j) 3.79×10^{-6} | k) 6.91×10^{-2} | l) 9.4×10^{-5} |

5) Write down these numbers in order of size, smallest first.

- 2.3×10^4 5.63×10^3 9.54×10^2 1.76×10^4 6.7×10^2 6.8×10^3

6) Write down these numbers in order of size, smallest first.

- 4.78×10^{-2} 6.78×10^{-4} 5.31×10^{-3} 9.85×10^{-2} 5.1×10^{-3} 4.2×10^{-5}

7) Which of the following have the same value as 4.21×10^5 ?

- | | | | |
|--------------------|---------------------|----------------------|------------------------|
| 42.1×10^6 | 0.421×10^6 | 0.0421×10^8 | 421000 |
| 421×10^3 | 4210×10^3 | 4210000 | 0.000421×10^7 |

8) Which of the following have the same value as 1.45×10^{-6} ?

- | | | | |
|--------------------------|-------------------------|-----------------------|-----------------------|
| 0.00145×10^{-4} | 145×10^{-8} | 0.0000145 | 1,450,000 |
| 1450×10^{-9} | 0.0000145×10^2 | 14.5×10^{-5} | 14.5×10^{-7} |

9) Which of the following have the same values as 4.83×10^4 ?

- 4.83^4 48.3^3 $(4.83 \times 10)^4$ 48.3×10^3 0.483×10^5

Standard Form 2

Do not use a calculator

L.8

1) a) If $\frac{1}{5000} = 0.0002$ write down $\frac{1}{50}$ and $\frac{1}{500}$ in standard form.

b) Calculate (i) $\frac{1}{50} + \frac{1}{500}$ and (ii) $\frac{1}{50} + \frac{1}{5000}$ leaving your answer in standard form.

2) Calculate each of the following, leaving your answer in standard form.

a) $1.32 \times 10^4 + 2.31 \times 10^4$

b) $5.42 \times 10^{-2} + 3.15 \times 10^{-2}$

c) $4.5 \times 10^4 + 2.1 \times 10^5$

d) $3.12 \times 10^{-3} + 2.41 \times 10^{-2}$

e) $4.21 \times 10^5 - 9.31 \times 10^4$

f) $3.21 \times 10^{-4} - 7.31 \times 10^{-5}$

3) Write down each of the following as simply as possible in standard form.

a) $(2 \times 10^3) \times (3 \times 10^3)$

b) $(4 \times 10^2) \times (2 \times 10^4)$

c) $(3 \times 10^5) \times (3 \times 10^2)$

d) $(2.5 \times 10^4) \times (3 \times 10^3)$

e) $(4 \times 10^2) \times (3 \times 10^7)$

f) $(3 \times 10^3) \times (5 \times 10^{-3})$

g) $(5 \times 10^4) \times (7 \times 10^{-2})$

h) $(6 \times 10^{-4}) \times (8 \times 10^4)$

i) $(7 \times 10^{-2}) \times (4 \times 10^5)$

j) $(5 \times 10^6) \times (8 \times 10^{-3})$

4) Write down each of the following as simply as possible in standard form.

a) $\frac{10^6}{10^3}$

b) $\frac{4 \times 10^6}{2 \times 10^2}$

c) $\frac{3 \times 10^4}{10^3}$

d) $\frac{1.5 \times 10^6}{3 \times 10^3}$

e) $\frac{4.5 \times 10^7}{1.5 \times 10^3}$

f) $\frac{2.1 \times 10^7}{7 \times 10^3}$

g) $\frac{1.8 \times 10^9}{6 \times 10^3}$

h) $\frac{2.8 \times 10^7}{4.0 \times 10^5}$

i) $\frac{1.3 \times 10^5}{2.6 \times 10^3}$

j) $\frac{6.3 \times 10^5}{7 \times 10^2}$

k) $\frac{5 \times 10^5}{2 \times 10^2}$

l) $\frac{4.8 \times 10^5}{2.4 \times 10^3}$

5) $\frac{4 \times 10^2}{2 \times 10^{-2}}$ can be written more simply as 2×10^4 . Simplify these.

a) $\frac{6 \times 10^3}{2 \times 10^{-2}}$

b) $\frac{5 \times 10^4}{2 \times 10^{-3}}$

c) $\frac{6 \times 10^7}{3 \times 10^{-2}}$

d) $\frac{8.1 \times 10^4}{9 \times 10^{-2}}$

6) $\frac{9 \times 10^{-4}}{2 \times 10^3}$ can be written more simply as 4.5×10^{-7} . Simplify these.

a) $\frac{9 \times 10^{-2}}{3 \times 10^2}$

b) $\frac{6.3 \times 10^{-3}}{3 \times 10^5}$

c) $\frac{5.6 \times 10^{-2}}{7 \times 10^7}$

d) $\frac{6.4 \times 10^{-5}}{8 \times 10^2}$

Question in Standard Form

L.8

1) The approximate distances of the planets from the Sun are given in the table below.

Planet	Distance from the Sun in km	Distance compared to Earth
Mercury	5.8×10^7	0.39
Venus	1.1×10^8	
Earth	1.5×10^8	1
Mars	2.3×10^8	
Jupiter	7.8×10^8	
Saturn	1.4×10^9	
Uranus	2.9×10^9	
Neptune	4.5×10^9	
Pluto	5.9×10^9	39.3

The final column compares the distance of the earth from the Sun with the distances of the other planets from the Sun.

a) Complete the table.

b) The speed of light is approximately 3×10^8 metres per second. Use the values above to calculate how long it takes for light to travel from the Sun to the Earth.

c) How long will it take for light to travel from the Sun to Pluto?

2) The diameter of Mars is 6.79×10^6 metres. Two man made satellites circle the planet at different altitudes and at different velocities.

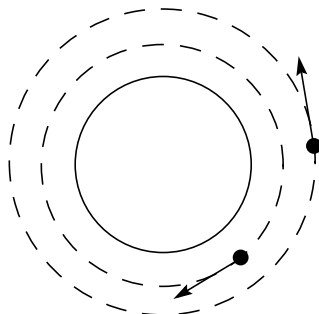

The satellites are circling at heights of 150km and 260 km above the surface of Mars.

a) What is the maximum possible distance between the satellites?

b) What is the minimum possible distance between the two satellites?

3) If 1cm is approximately equal to 0.395 inches, how many cubic centimetres are there in 1 cubic foot? Give your answer in standard form.

Repeated Proportional Change

L.8

- 1) The population of a village at the end of 1998 was 1,450. At the end of the next year it was found to have risen by 10%. At the end of the next year it rose by a further 8%. What was the population at the end of 2000?
- 2) Arlan puts £1000 into a bank account. He plans to leave it there for three years. He is told when he puts the money in that it will grow by 5% each year. Arlan says 'After 3 years I will have £1150 in the bank'
- a) Explain why Arlan is wrong.
- b) Calculate the true amount of money Arlan will have in the bank after 3 years.
- 3) A car costs £8,000. At the end of the first year its value depreciates by 12%.
- a) Which of the following calculations will work out its new value?
 8000×1.12 8000×0.12 8000×0.88 8000×1.08
- b) The next year it will depreciate in value by a further 9%. What calculation must be carried out in order to find its new value?
- c) What is its value at the end of the second year?
- 4) A business employed 2000 people at the end of 1995. The table below shows the number of employees at the end of subsequent years.

End of 1995	2000
End of 1996	10% more
End of 1997	10% more
End of 1998	10% more

- a) Which of the following is used to calculate the number of employees in the company at the end of 1998?
 2000×0.3 2000×1.3 $(2000 \times 1.1)^3$ 2000×1.1^3 2000×3.3
- b) Calculate the number of people employed by the company at the end of 1998.
- 5) Two people go to a restaurant. The food costs £60. To that is added a service charge of 10%. To the new total a tax (VAT) of $17\frac{1}{2}\%$ added.
- a) Which of the following calculations will work out their final bill?
 60×2.275 60×1.2925 60×1.275 60×2.2925
- b) Explain how this calculation is arrived at.

Calculating the Original Amount

L.8

- 1) A bicycle shop increases all its prices by 12%. One of their bicycles now costs £134.40. What was its price before the increase?
- 2) A company reduced its number of employees by a tenth to 675. How many employees did they have before the reduction?
- 3) At the end of the season a garden centre reduced the prices of all its spring plants by 40%. If a plant now costs £7.50, what was its price before the sale?
- 4) A shop had a sale. All its prices were reduced by 10%. A coat costs £63 in the sale. What was its price before the sale?
- 5) A length of wood has $\frac{3}{8}$ cut away. It now measures 85cm. What was the original length of the wood?
- 6) The cost of a rail journey is increased by 4% to £7.80. What was its cost before the increase in price?
- 7) A crowd of 38,270 at a Premier Division football match was 14% fewer than the previous week. How many went to the previous week's match?
- 8) Kamala gives half of her weekly wages to her mum for her keep. One third of the remainder she saves and the rest, £54, she spends on herself. How much money does Kamala earn in a week?
- 9) The height of a tree increased by 16% over a period of a year to 6.93 metres. Bob wants to calculate its height at the beginning of the year.
 - a) Which of the following calculations should he do?
 6.93×1.16 6.93×0.84 $6.93 \div 1.16$ $6.93 \div 0.84$
 - b) What was the height of the tree at the beginning of the year?
- 10) Gwyneth invested some money in a bank account. She left the money in for two years. At the end of the first year her investment had interest of 4% added to it. At the end of the second year a further 4% was added to it. She then had £1,622.40 in her account.
 - a) Calculate the amount in her account at the end of the first year.
 - b) What was her original investment?

Proportion

L.8

- 1) The table below shows the population of two towns, Greystock and Thrusham in 1980 and 2000.

	1980	2000
Greystock	43,520	
Thrusham	27,840	36,480

- a) In Greystock the population fell by 15.4% between 1980 and 2000.
What was the population in Greystock in 2000?
- b) In Thrusham the population increased between 1980 and 2000.
Calculate the percentage increase to 1 decimal place.
- c) Between 1980 and 2000 the population of two other towns, Kinster and Flockborough increased by the same amount. The percentage increase in Kinster was greater than the percentage increase in Flockborough.
Which of the following statements below is true?
 'In 1980 the population in Kinster was higher than in Flockborough'
 'In 1980 the population in Kinster was lower than in Flockborough'
 'In 1980 the population in Kinster was the same as that in Flockborough'
 'From the information given you cannot say whether Kinster or Flockborough had the higher population'
- 2) A company makes laptop computers and mobile phones. The table below shows the value of their sales in thousands of pounds for 1994 and 2000.

	1994	2000
Laptop Computers	11,200	14,300
Mobile Phones	1,400	

- a) What was the percentage increase in the value of the company's laptop computer sales between 1994 and 2000?
- b) The company's sales of mobile phones increased by 2400% between 1994 and 2000. What was the value of their sales in 2000?
- c) What proportion of their 1994 sales were mobile phones?
- d) What proportion of their 2000 sales were mobile phones?

Letters and %

L.8

- 1) A length of string is x cm. Another piece measures $x + 5$ cm. If the second piece is 20% longer than the first, calculate the value of x .
- 2) In 1998 the cost of a bus fare was x pence. In 1999 it increased by 10%.
 - a) What was its price in 1999 in terms of x ?In 2000 the price increased by a further 8%.
 - b) What was the new price in terms of x ?
 - c) If a bus ticket cost £1.50 in 1998, how much did it cost in 2000? (correct to the nearest penny)
- 3) A length of string measuring y centimetres is cut in half. One of the pieces is discarded and the other is cut into thirds. Two of these pieces are discarded and the remaining one is cut in half.
 - a) What is the length of one of these pieces in terms of y ?
 - b) If the original length of string was 600cms, what were the lengths of each of the two final pieces of string?
- 4) The length of a rectangular piece of wood is x cm and its width is y cm. The rectangle is made smaller by cutting 20% off its length and 10% from its width.
 - a) By what percentage does its area decrease?Another piece of wood with the same dimensions has 10% cut from its length and 20% cut from its width.
 - b) By what percent does its area decrease?
 - c) If the original length was 150cm and its width was 40cm, calculate their final areas in each case.
- 5) The population of a town in 1998 was n people. During 1999 the population increased by 8%. During 2000 the population decreased by 2%.
What was the population of the town at the end of 2000 as a percentage of n ?
- 6) A rectangle has a length of x cm and a width of y cm.
 - a) What is its area in terms of x and y ?Another rectangle has the same area, but its width is 10% greater.
 - b) By what percentage is its length smaller?A rectangle measures 110cm by 100cm.
 - c) What are the dimensions of a rectangle having the same area with one side 10% greater?

Substitution

L.8

1) If $a = 0.25$, $b = -2.58$, $c = 4.25$ and $d = -0.24$ calculate the value of each of the following giving your answer correct to 2 decimal places wherever necessary.

- | | | | |
|------------------------------------|-------------------------------------|---------------------|------------------------------------|
| a) $a + c$ | b) $b + d$ | c) $a - c$ | d) $a - d$ |
| e) $2c + 3b$ | f) $2a - 2b$ | g) $3a + 7b$ | h) $4a - 3b$ |
| i) $(c - a)^2$ | j) $\sqrt{c^2 + a^2}$ | k) $\sqrt{b^2 + c}$ | l) $3\sqrt{c + d}$ |
| m) $3b(a + b)^2$ | n) $\frac{a^2 + b^2}{c^2}$ | o) $2a - 3(b + c)$ | p) $\frac{2b - 2(b^2 + c^2)}{a^2}$ |
| q) $\frac{3b - 2(a^2 + b^2)}{c^2}$ | r) $\frac{b + c^2}{d^2}$ | s) $4c(b - d)^2$ | t) $\frac{d + 4(a^2 + d^2)}{b^2}$ |
| u) $3c + 4(a - d)$ | v) $\frac{c - \sqrt{a^2 - 3bc}}{3}$ | w) $2c(b - a)^2$ | x) $\frac{-3(a^2 + d^2)}{c}$ |

2) The solution to the quadratic equation $ax^2 + bx + c = 0$ can be found by using the equation:-

$$x = \frac{-b \pm \sqrt{b^2 - 4ac}}{2a}$$

For example, the solution to $2x^2 + 6x - 1 = 0$ is:-

$$\begin{aligned} x &= \frac{-6 \pm \sqrt{36 - 4 \times 2 \times (-1)}}{2 \times 2} = \frac{-6 \pm \sqrt{36 + 8}}{4} \\ &= \frac{-6 \pm \sqrt{44}}{4} = \frac{-6 + 6.633}{4} \text{ or } \frac{-6 - 6.633}{4} \end{aligned}$$

so $x = 0.16$ or -3.16 correct to 2 decimal places

i.e. the quadratic has two solutions, either $x = 0.16$ or $x = -3.16$

Use the formula $x = \frac{-b \pm \sqrt{b^2 - 4ac}}{2a}$ to solve the following quadratics

- | | | |
|------------------------|------------------------|-------------------------|
| a) $2x^2 - 7x + 6 = 0$ | b) $2x^2 - x - 10 = 0$ | c) $x^2 + x - 12 = 0$ |
| d) $x^2 - 4x - 3 = 0$ | e) $4x^2 - 7x + 1 = 0$ | f) $10x^2 + 2x - 7 = 0$ |
| g) $2x^2 - 7x - 3 = 0$ | h) $3x^2 - 5x + 1 = 0$ | i) $5x^2 + 4x - 7 = 0$ |
| j) $x^2 - 5x + 3 = 0$ | k) $3x^2 - 4x - 2 = 0$ | l) $9x^2 - x - 8 = 0$ |

How many Solutions?

L.8

1) Equations can have different numbers of outcomes. For example:-

$$2x - 1 = 5 \text{ has one solution, } x = 3$$

$$3x - 2 = 2x - 2 + x \text{ is correct for all numbers}$$

$$x^2 = 9 \text{ has 2 solutions, } 3 \text{ and } -3$$

Say whether the following are true for (i) one value, (ii) two values or (iii) all values of x

a) $x + 4 = 12$

b) $2x - 3 = 13$

c) $x^2 = 25$

d) $\frac{3}{4}x = 19$

e) $\frac{x^2 + 4}{3} = 7$

f) $x = 3x + 4$

g) $\frac{2x-1}{2} = 6$

h) $3x^2 - 17 = 54$

i) $\frac{5x-7}{3} = \frac{x-1}{2}$

j) $\frac{2x-1}{2} = \frac{4x-2}{4}$

k) $4 + 6x = 12$

l) $x^2 = 41$

m) $\frac{1}{3}x = 17$

n) $33 - x^2 = 6$

o) $3x + 17 = 4x + 10 - x + 7$

p) $2x^2 = 98$

q) $\frac{x+4}{3} = 7$

r) $x^2 - 7 = 32$

s) $2x + 3 = 3x - 1$

t) $3x - 2 = 2x + 3$

u) $\frac{x^2-9}{4} = 3$

2) Calculate the values of x which satisfy the following equations.

a) $x^2 = 100$

b) $x^2 - 7 = 18$

c) $54 - x^2 = 5$

d) $x^2 + 17 = 138$

e) $84 - x^2 = 20$

f) $14 + x^2 = 95$

g) $(x + 3)^2 = 100$

h) $(10 - x)^2 = 16$

i) $(4 + x)^2 = 121$

j) $\frac{x^2 - 4}{4} = 3$

k) $\frac{x^2 + 11}{3} = 12$

l) $\frac{3x^2 - 15}{4} = 15$

m) $\frac{2x^2 + 3}{5} = 7$

n) $\frac{x^2 - 10}{6} - 9 = 0$

o) $\frac{5x^2 - 20}{3} - 20 = 0$

p) $\frac{25}{x+2} = x + 2$

q) $\frac{100}{x-4} = x - 4$

r) $\frac{36}{x+4} = 4 + x$

3) Which of the following equations have only one solution?

a) $x^2 = 63$

b) $x^2 + 16 = 16$

c) $23 - x^2 = 4$

d) $x^2 + 24 = 96$

e) $53 - x^2 = 27$

f) $34 + x^2 = 34$

g) $\frac{x^2 + 4}{4} = 1$

h) $\frac{x^2 + 9}{5} = 19$

i) $\frac{5x^2 - 1}{4} = 15$

j) $\frac{2x^2 + 35}{5} = 7$

k) $\frac{x^2 - 9}{5} - 8 = 0$

l) $\frac{3x^2 + 27}{3} - 9 = 0$

Formulae

L.8

1) Rearrange the following formulae to make the letter in the brackets the subject.

- | | | | | | |
|-------------------|-----|------------------------|-----|----------------------|-----|
| a) $A = LB$ | (L) | b) $\pi = \frac{C}{D}$ | (C) | c) $y = \frac{x}{a}$ | (a) |
| d) $v = u + at$ | (u) | e) $v = u + at$ | (a) | f) $y = x(a + b)$ | (x) |
| g) $y = x(a + b)$ | (b) | h) $A = \pi r^2$ | (r) | i) $l = xy\sqrt{w}$ | (w) |

2)

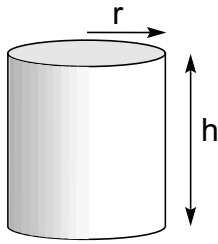

The volume of a cylinder is calculated with the formula $V = \pi r^2 h$.

- a) If $r = \frac{d}{2}$, substitute this in the formula and simplify your answer.
- b) If the height of the cylinder is the same as the radius, what is its volume in terms of the diameter?

3)

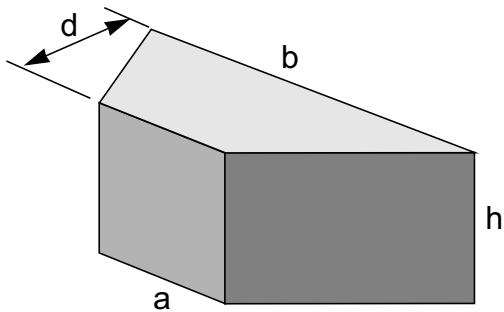

This regular trapezoidal prism has a height of h centimetres and a depth of d centimetres. The two opposite edges of the trapezium are a and b centimetres.

The volume of this shape is given by the formula:-

$$V = \frac{1}{2}(a + b)dh$$

- a) What is its volume if the height and depth are equal?
- b) What is its volume if a , d and h are equal and $a = \frac{1}{2}b$? Give your answer in terms of a .

4)

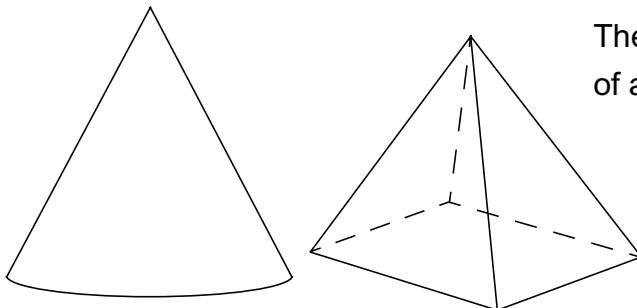

The formula for calculating the volume of a prism or cone like these is

$$\text{Volume} = \frac{1}{3} \text{ area of base} \times \text{height}$$

- a) What is the volume of a cone whose height is h and base radius is r ?
- b) What is the volume of a cone whose height and base diameter d are equal?
- c) What is the volume of a pyramid with a base of sides x and y and height h ?
- d) What is the volume of a pyramid with a base of sides x and a height of $2x$?

In each case simplify your answer as far as possible.

Simultaneous Equation Problems

L.8

- 1) In September, the maths department bought 5 reams of lined paper and 2 reams of graph paper for £25.
In January, they bought 6 reams of lined paper and 4 reams of graph paper for £38.
Write down two simultaneous equations, letting x represent the cost of a ream of lined paper and y the cost of a ream of graph paper. Use these equations to calculate the values of x and y .
In May they bought 6 reams of lined paper and 2 reams of graph paper. What did it cost?
- 2) Mrs. Jenkins buys 5kg of potatoes and 3kg of carrots for £1.38.
Mr Parry buys 8kg of potatoes and 4kg of carrots for £2.04.
Letting x represent the cost of the potatoes and y the cost of the carrots, write down two simultaneous equations.
Showing all your workings, calculate the values of x and y .
What will Mr Pugh have to pay for 7kg of potatoes and 2kg of carrots?
- 3) Dean has a number of small weights all of the same mass, and some larger weights all of the same mass. He tries to calculate their sizes by weighing them against two packets of cheese he has. The 220g block of cheese weighs the same as 4 small weights and 3 large weights. The 250g block of cheese weighs the same as 2 small weights and 5 large weights.

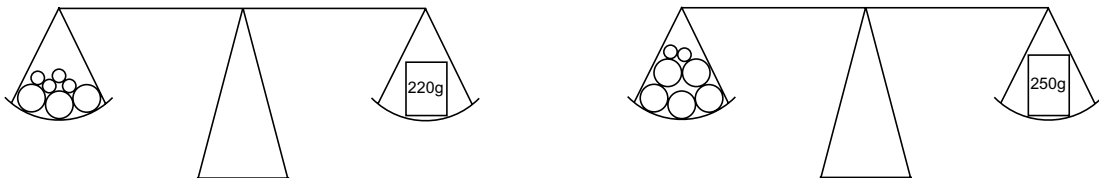

Letting x represent the mass of a small weight and y the mass of a large weight, write down two simultaneous equations.

Use the equations to calculate the masses of the two sizes of weights.

- 4) A quiz game has two types of question, hard and easy.
Team A answers 3 hard questions and 5 easy questions correctly to get 25 points.
Team B answers 4 hard questions and 2 easy questions correctly to get 24 points.
Write down two simultaneous equations using h to represent the points scored for answering a hard question correctly and e to represent the points scored when answering an easy question correctly.
Use the equations to calculate the values of h and e .
Team C answers 6 hard questions correctly and 1 easy question correctly.
How many points do they score?

Equations from Experimental Data

L.8

- 1) A garage hires out a minibus. The daily charge is shown in the table below.

Number of days d	1	2	3	4	5	6
Cost in pounds C	45	70	95			

- a) Complete the table.
 b) Write down an equation for C , the cost to hire the bus, in terms of the number of days d it is hired for.

$$C = \dots$$

- c) Use the formula to calculate the cost of hiring the minibus for 10 days.
 d) How many days can the bus be hired for it to cost £445?

- 2) Water is put into a large tank through a hosepipe. The supply of water entering the tank never varies. The tank has a circular cross section and its sides are vertical. The tank has some water in it before the hosepipe is turned on. The table below shows the depth of the water at 5 minute intervals.

Time in minutes t	5	10	15	20	25	30
Depth in cm D	23	38	53			

- a) Complete the table.
 b) Write down an equation linking the depth of water D to the time taken t minutes.

$$D = \dots$$

- c) Use the formula to calculate the depth of water in the tank after it has been running for 22 minutes.
 d) The tank has a depth of 130 centimetres. How long will it take to fill the tank?

- 3) A metal container is to be designed in the shape of a cylinder, open at the top. Its capacity is to be 10 litres. The table below shows the values of heights and base areas that give a 10 litre capacity.

Height of Can H cm	10		50		200
Area of Base A cm ²		500		100	

- a) Complete the table.
 b) Write down an equation linking the capacity of the can, C litres, to the height of the can, H cm, and the area of the base, A cm².

$$C = \dots$$

- c) The size which the designer chooses has a base area of 400cm². What is its height?
 d) Another can is designed so that its height and diameter are equal. Calculate its height, correct to the nearest 0.1mm.

Solving Equations

L.8

1) Calculate the value of x in each of the following.

a) $4(x + 3) + 4 = 20$

b) $2(x - 1) + 7 = 23$

c) $5(x - 2) - 6 = 24$

d) $3(x + 5) + x = 35$

e) $2(x - 2) - x = 2$

f) $x + 5(x + 4) = 80$

g) $3x + 3(3x - 2) = 54$

h) $4(x + 2) - 2x = 22$

i) $2(2x + 3) - 5x = -6$

j) $3(x + 2) - 2(3x - 5) = -14$

k) $2(x + 2) + 3(x + 1) = 57$

l) $4(x - 2) - 2(x + 3) = -2$

m) $3(x + 4) = 5(x + 2)$

n) $4(2x + 3) = 9(2x - 2)$

o) $3(11x - 7) = 5(4x + 1)$

p) $7(3x + 1) = 8(3x - 1)$

2) Calculate the value of x in each of the following.

a) $\frac{x-2}{3} = 2$

b) $\frac{x-1}{4} = 3$

c) $\frac{x+3}{4} = 1$

d) $\frac{2x+4}{2} = 6$

e) $\frac{3x-6}{3} = 3$

f) $\frac{3x+2}{5} = 10$

g) $\frac{2x+2}{3} = x$

h) $\frac{5x-6}{7} = x$

i) $\frac{4x+1}{6} = x$

j) $\frac{10+x}{3} = 2x$

k) $\frac{18-3x}{2} = 3x$

l) $\frac{14+x}{2} = 4x$

m) $\frac{2x}{2x-3} = 4$

n) $\frac{6-2x}{5x} = 2$

o) $\frac{16+x}{3x} = 3$

p) $\frac{3x}{2x-4} = 3$

q) $\frac{3x}{x+1} = 5$

r) $\frac{10+x}{3x} = 2$

3) Calculate the value of x in each of the following.

a) $\frac{x-2}{2} + \frac{x+4}{2} = 2$

b) $\frac{x+1}{3} + \frac{x+3}{3} = 3$

c) $\frac{x-1}{5} + \frac{x+7}{5} = 4$

d) $\frac{2x-4}{4} + \frac{x+3}{4} = 7$

e) $\frac{x+3}{6} + \frac{4x+5}{6} = 8$

f) $\frac{5x-1}{4} + \frac{x+9}{4} = 8$

g) $\frac{x-4}{2} + \frac{x+1}{4} = 8$

h) $\frac{x+3}{3} + \frac{x+3}{6} = 5$

i) $\frac{x-2}{4} + \frac{x+4}{2} = 6$

j) $\frac{x-6}{2} = \frac{x+2}{4}$

k) $\frac{x+1}{2} = \frac{x+5}{3}$

l) $\frac{x-1}{3} = \frac{x+2}{4}$

m) $\frac{2x-4}{2} = \frac{3x+6}{5}$

n) $\frac{x+2}{3} = \frac{2x+1}{4}$

o) $\frac{4x-3}{3} = \frac{2x+4}{2}$

Factorising Expressions

L.8

1) If $a^2 - b^2 = (a - b)(a + b)$, factorise each of the following and simplify further wherever possible.

a) $x^2 - y^2$

b) $m^2 - n^2$

c) $c^2 - d^2$

d) $x^2 - 2^2$

e) $m^2 - 3^2$

f) $c^2 - 4^2$

g) $x^2 - 9$

h) $m^2 - 16$

i) $c^2 - 25$

j) $23^2 - 17^2$

k) $37^2 - 23^2$

l) $46^2 - 44^2$

m) $9x^2 - y^2$

n) $16m^2 - n^2$

o) $25c^2 - d^2$

p) $25x^2 - 4y^2$

q) $36m^2 - 9n^2$

r) $81c^2 - 25d^2$

s) $b^2 - 1$

t) $a^2b^2 - 9$

u) $a^2b^2 - 1$

2) Simplify each of the following by first finding common factors.

a) $\frac{1}{2}a + \frac{1}{2}b$

b) $\frac{1}{3}ab + \frac{1}{3}a$

c) $\frac{1}{4}xy - \frac{1}{4}y$

d) $x + \frac{1}{2}x^2$

e) $\frac{1}{4}a^2 + ab$

f) $\frac{1}{5}b^2 - b$

g) $\frac{1}{2}a + \frac{1}{4}ab$

h) $\frac{1}{2}ab - \frac{1}{4}b^2$

i) $\frac{1}{2}y^2 - \frac{1}{2}y$

j) $\frac{3}{4}a + ab$

k) $4a^2b + \frac{1}{2}ab^2$

l) $\frac{1}{2}a^2 + \frac{1}{4}a$

m) $\frac{1}{2}b + \frac{1}{4}b^2$

n) $\frac{1}{3}a + \frac{2}{3}a^2$

o) $\frac{1}{2}x + x^2$

p) $\frac{3}{4}ab - \frac{1}{4}b$

q) $\frac{3}{8}x^2 - \frac{1}{8}xy$

r) $\frac{7}{8}b - \frac{1}{4}b^2$

3) Factorise each of the following expressions.

a) $\frac{a}{2} - \frac{b}{2}$

b) $\frac{bc}{5} - \frac{b}{5}$

c) $\frac{ab}{4} + \frac{b}{4}$

d) $\frac{a}{2} + \frac{ab}{4}$

e) $\frac{ab}{4} + \frac{a}{8}$

f) $\frac{2a}{3} + \frac{b}{6}$

g) $\frac{a}{4} - \frac{ab}{4}$

h) $\frac{xy}{2} - \frac{y}{2}$

i) $\frac{y^2}{4} - \frac{y}{4}$

j) $\frac{b}{2} + \frac{3a}{4}$

k) $\frac{5a}{8} + \frac{ab}{4}$

l) $\frac{x^2}{2} + \frac{xy}{4}$

m) $\frac{a^2b}{2} + \frac{a}{4}$

n) $\frac{ab^2}{2} + \frac{ab}{4}$

o) $\frac{xy}{2} + \frac{xyz}{4}$

p) $\frac{a}{2} + \frac{ab}{4}$

q) $\frac{a}{2} + \frac{a^2}{4}$

r) $\frac{a^2}{2} + \frac{a}{4}$

s) $\frac{c}{2} - \frac{c^2}{4}$

t) $\frac{3y^2}{4} + \frac{xy}{4}$

u) $\frac{a}{2} + a^2 - \frac{ab}{2}$

Triangular Numbers

L.8

The arrangements of discs below show the square numbers.

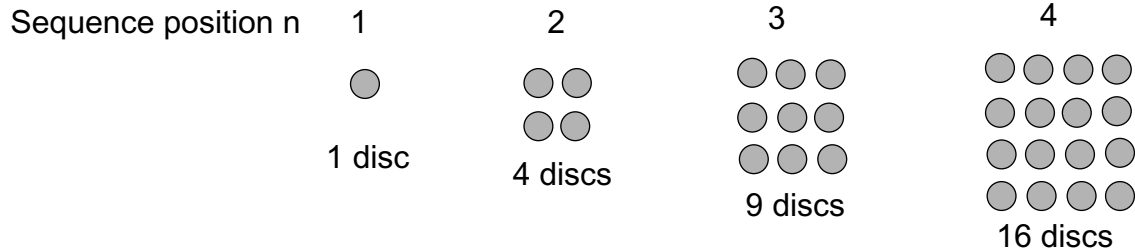

a) What are the next two numbers of discs in the sequence?

The equation for finding the number of discs in an arrangement is

$$D = n^2$$

where D is the number of discs and n is the sequence position

b) Write down the 2 values of n for the inequality:-

$$1000 < D < 1100$$

Grace wants to find an equation for triangular numbers. She says that she can do this by considering the square numbers. The grey discs below represent the series of triangular numbers. Grace has taken some discs away from the square sequence to get the triangular sequence.

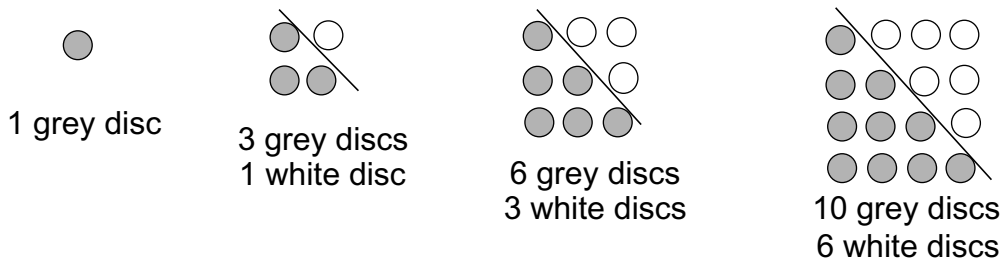

c) Which of the following equations represent the white discs?

$$W = \frac{1}{2}n(n^2 - 1)$$

$$W = \frac{1}{2}n^2 - 1$$

$$W = \frac{1}{2}n^2 - n$$

$$W = \frac{1}{2}n(n^2 - n)$$

$$W = \frac{1}{2}n(n - 1)$$

$$W = \frac{1}{2}n(n + 1)$$

Grace now writes this equation for the sequence of triangular numbers.

$$G = \frac{1}{2}(n^2 + n)$$

d) Show how Grace gets this result.

The Graph of $y = x^2$

L.8

- 1) The diagram on the right shows the graph of $y = x^2$ and its reflection in the x axis. Write down the co-ordinates of the points A, B, C and D.

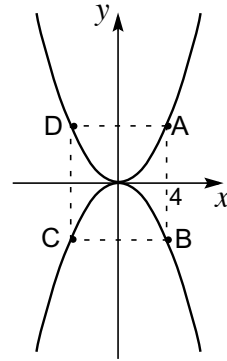

- 2) The diagram on the right shows the graphs of $y = x^2$ and $y = (x - 4)^2$. Write down the co-ordinates of the points A and B.

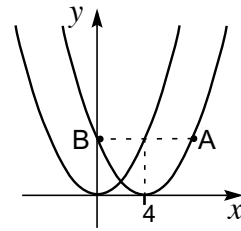

- 3) The diagram on the right shows the graphs of $y = x^2$ and its reflection in the line $x = -2$.
 a) Write down the co-ordinates of the points A and B.
 b) What is the equation of the reflected graph?

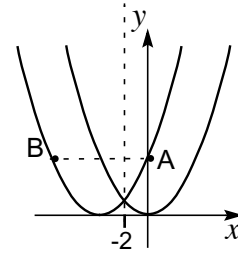

- 4) The diagram on the right shows the graphs of $y = x^2$ and its reflection in the line $y = 9$.
 a) Write down the co-ordinates of the points of intersection of the two graphs.
 b) What is the equation of the reflection?

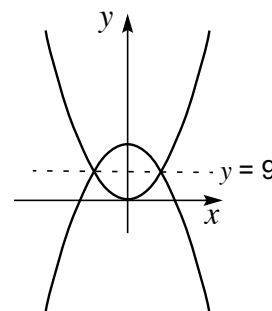

- 5) The diagram on the right shows the graphs of $y = x^2$ and its translation 2 units in the y direction.
 a) Write down the co-ordinates of the points A and B.
 b) What is the equation of the translated graph?

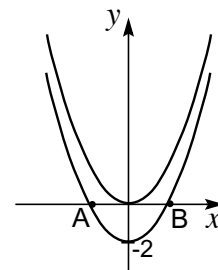

Inequality Questions

L.8

1) A number in the series 0, 0, 1, 3, 6... can be calculated by using the expression

$$\frac{(n-1)(n-2)}{2} \text{ where } n \text{ is a whole number.}$$

For example the 10th number in the series is $\frac{9 \times 8}{2} = 36$

a) By using a trial and improvement method, calculate the three values of n which satisfy the inequality:-

$$500 < \frac{(n-1)(n-2)}{2} < 600$$

b) By using a trial and improvement method, calculate the smallest number in the series which satisfies the inequality:-

$$\frac{(n-1)(n-2)}{2} > 1500$$

c) By comparing $\frac{(n-1)(n-2)}{2}$ and $\frac{(n-2)(n-3)}{2}$, write down the first 5 numbers in the series formed by the expression $\frac{(n-2)(n-3)}{2}$. Check your answers by substitution.

2) A number in the series 0, 2, 9, 24, 50... can be calculated by using the expression

$$\frac{n^2(n-1)}{2} \text{ where } n \text{ is a whole number.}$$

For example the 10th number in the series is $\frac{100(10-1)}{2} = 450$

a) By using a trial and improvement method, calculate the two values of n which satisfy the inequality:-

$$5000 < \frac{n^2(n-1)}{2} < 6000$$

b) By using a trial and improvement method, calculate the smallest number in the series which satisfies the inequality:-

$$\frac{n^2(n-1)}{2} > 100,000$$

c) By comparing $\frac{n^2(n-1)}{2}$ and $\frac{n^3(n-1)}{2}$, write down the first 5 numbers in the series formed by the expression $\frac{n^3(n-1)}{2}$. Check your answers by substitution.

Areas Bounded by Curves

L.8

- 1) The diagram on the right shows the graphs of $y = x^2 - 2$.

Which of the two inequalities below can be used to describe the shaded area below the x axis?

$$\begin{array}{ccc} y > x^2 & y < 0 & y > 2 \\ y > x^2 - 2 & y - 2 > x^2 & \end{array}$$

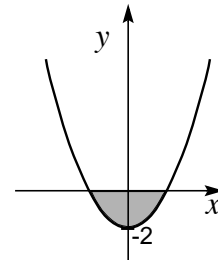

- 2) The diagram on the right show the graphs of $y = 7 - x^2$.

Which of the two inequalities below can be used to describe the shaded area above the x axis?

$$\begin{array}{ccc} x < 0 & y > 0 & y < 0 \\ y > 7 - x^2 & y < 7 - x^2 & \end{array}$$

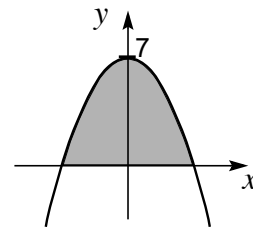

- 3) The diagram on the right shows the graph of $y = x^2$ and the line $y = 4$

Which of the two inequalities below can be used to describe the shaded area above the x axis?

$$\begin{array}{ccc} y < 4 & x < 4 & y > 4 \\ y < x^2 & y > x^2 & \end{array}$$

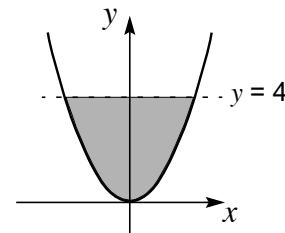

- 4) The diagram on the right shows the graph of $y = (x + 2)^2$ and the line $y = 9$

Which three of the inequalities below can be used to describe the shaded area to the left of the y axis?

$$\begin{array}{cccc} y < 9 & x < 0 & y > 9 & x < -2 \\ y < (x + 2)^2 & y < x^2 & y > (x + 2)^2 & \end{array}$$

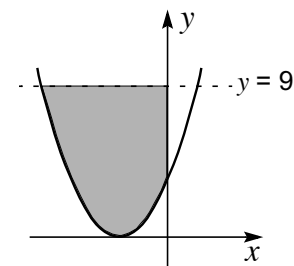

- 5) The diagram on the right shows the graph of $y = -(x^2 + 5)$ and the lines $x = -4$ and $x = 4$.

Which four of the inequalities below can be used to describe the shaded area below the x axis?

$$\begin{array}{ccccc} x > 4 & y < 0 & x < -4 & x > -4 & x < 4 \\ y < -(x^2 + 5) & y < x^2 & y > -(x^2 + 5) & \end{array}$$

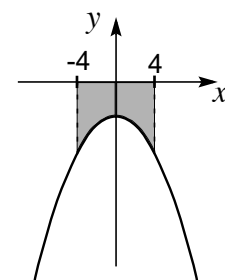

Pythagoras etc

L.8

1)

a)

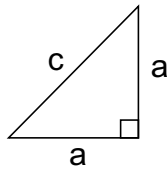

In this right angled triangle two sides are of the same length.

(i) Show that $a = \frac{c}{\sqrt{2}}$

(ii) What is the area of the triangle in terms of c ?

b)

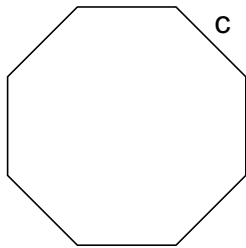

This diagram shows a regular octagon with each side measuring 'c' centimetres. Using the result from part 'a', calculate its area in terms of 'c'.

2)

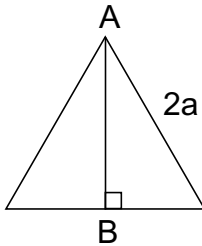

The diagram shows an equilateral triangle with sides of $2a$.

a) Show that the length of the perpendicular AB is $a\sqrt{3}$

b) Write down the area of the triangle in terms of 'a'

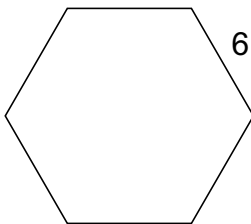

This regular hexagon has sides of 6 centimetres.

c) Use the results above to calculate its area

3)

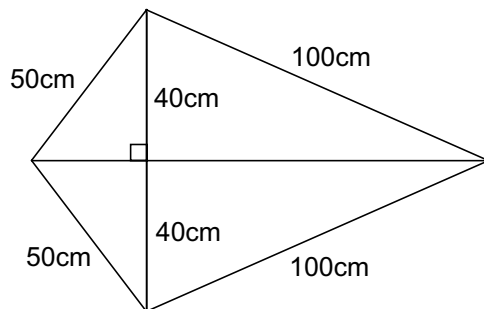

Calculate the area of this kite.

Areas

L.8

1) Calculate the areas of the shaded parts of these shapes.

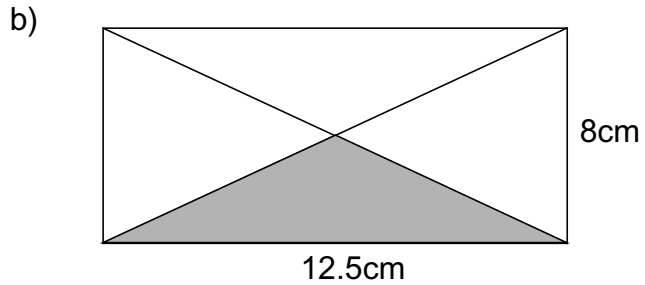
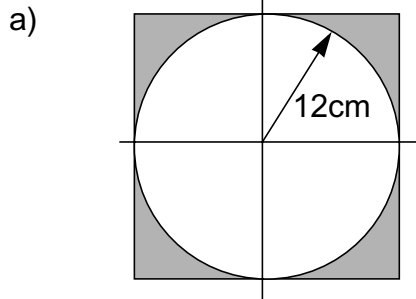

2)

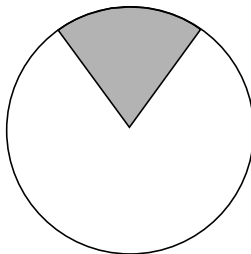

The diagram shows a circle with a sector shaded in. The angle of the sector at the centre is 60° and the radius of the circle is 12cm.

- What fraction of the circle has been shaded in?
- What is the area of the circle?
- What is the area of the sector?

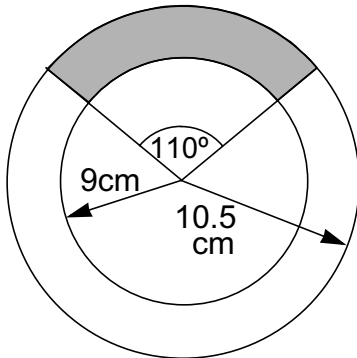

This diagram shows two concentric circles of radii 9cm and 10.5cm. A sector with a centre angle of 110° cuts the circles.

- Calculate the area of the shaded part.

3)

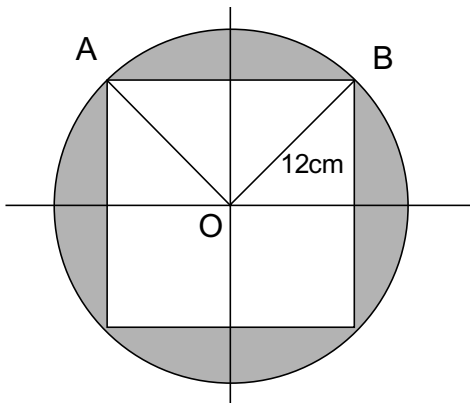

The diagram on the left shows a circle of radius 12cm and a square with diagonals of 24cm. The corners of the square touch the circle.

- Calculate the area of the triangle AOB.
- Calculate the area of the shaded part of the circle.

Areas and Perimeters

L.8

1)

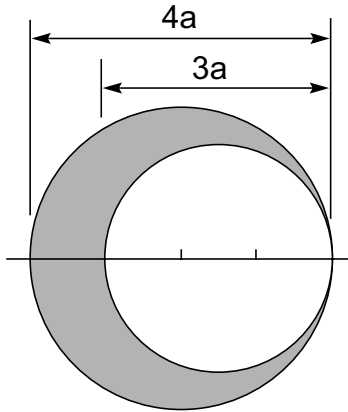

The two circles shown in the diagram have diameters of $3a$ and $4a$. Their edges touch and their diameters are on the same line.

Show that the area of the shaded part is

$$\frac{7}{4}\pi a^2$$

2)

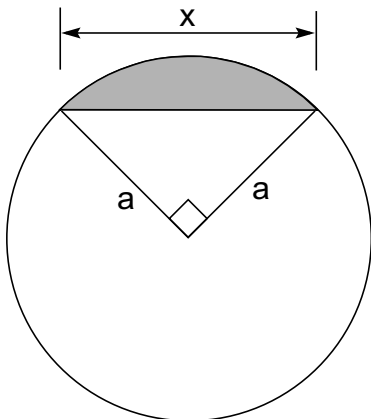

The diagram shows a circle of radius a centimetres. The sector has a right angle at the centre of the circle.

a) What is the area of the sector in terms of a ?

b) Show that the length of the chord x is $a\sqrt{2}$

c) Show that the area of the shaded segment is $\frac{a^2}{4}(\pi - 2)$

3)

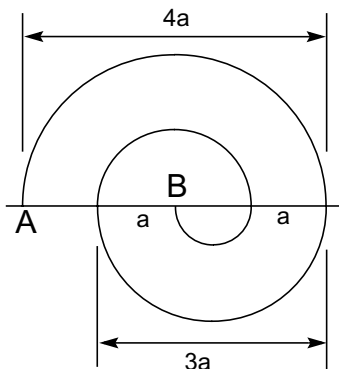

This shape is made up of 4 semicircles.

Show that the distance from A to B, along the curve, is $5\pi a$ centimetres.

Volume

L.8

- 1) A biscuit packet is in the shape of an octagonal prism. One end of the packet is shown. Four sides are each 4cm long. The height of the packet is 8cm and its width is 8cm. The other four sides are equal. It is filled with round flat biscuits.

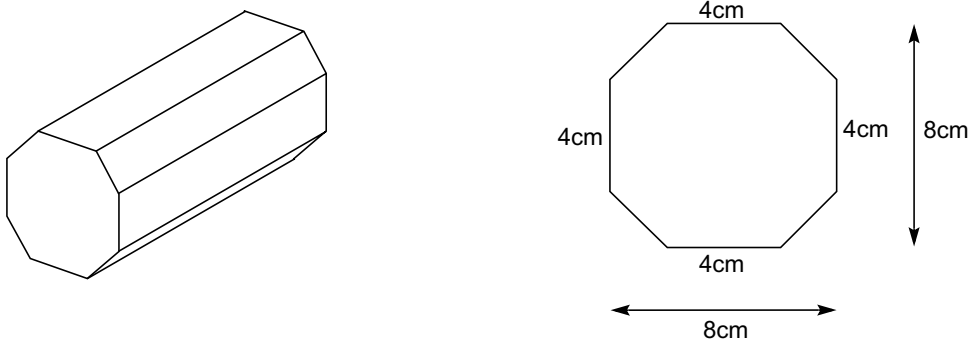

- What is the area of the end of the packet?
 - What is the maximum diameter of the biscuits that are put in the packet?
 - A packet holds 25 biscuits. Each biscuit is 6mm thick. What is the volume of the packet?
 - What percentage of the packet is taken up with biscuits?
 - The packets are put into cuboid shaped boxes designed to hold 100 packets. What is the size of the box? (You may ignore the thickness of the packaging)
- 2) Part of a child's toy is a plastic peg in the shape of a cylinder with a square hole through the middle. The minimum dimension between the hole and the outside is 1 centimetre.

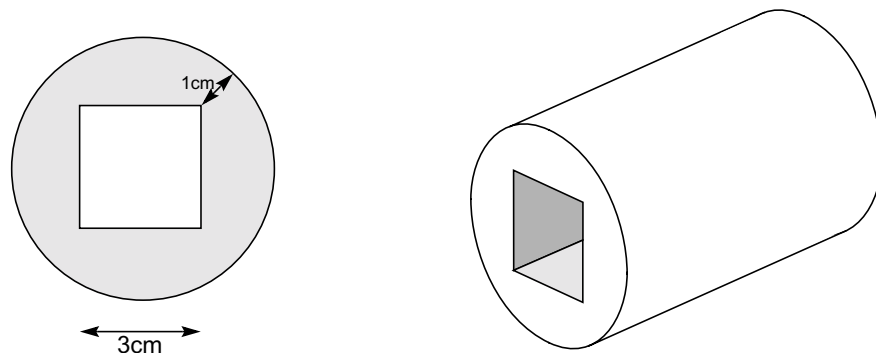

The sides of the square are 3cm.

- Use Pythagoras' theorem to calculate the diameter of the peg.
- What is the area of the end of the peg? (The shaded part of the first diagram)
- If the peg is 10cm long, what volume of plastic is needed to make the peg?
- If 1cm^3 of the plastic has a mass of 0.93g, calculate the mass of one of the pegs.
- If a batch of 125 pegs are made, what will be the total mass of plastic needed?

Congruent Triangles

L.8

1) Which three of these triangles are congruent?

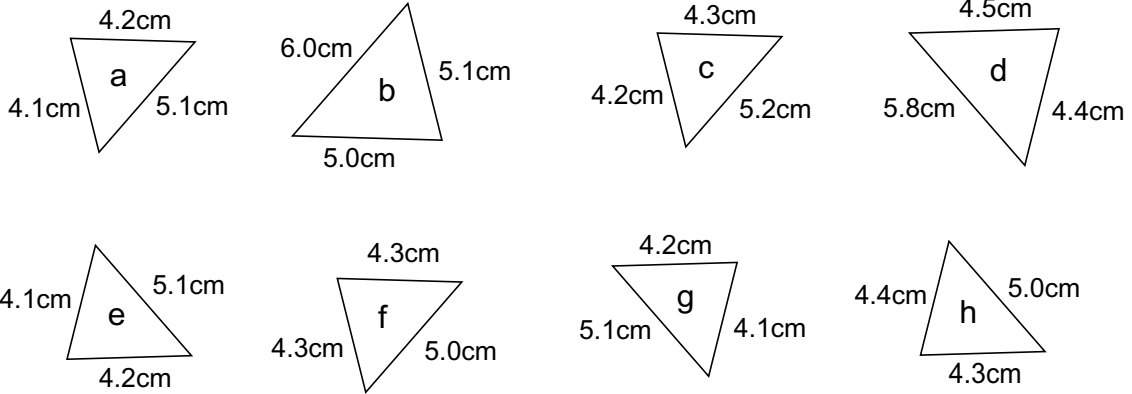

2) Which three of these triangles are congruent?

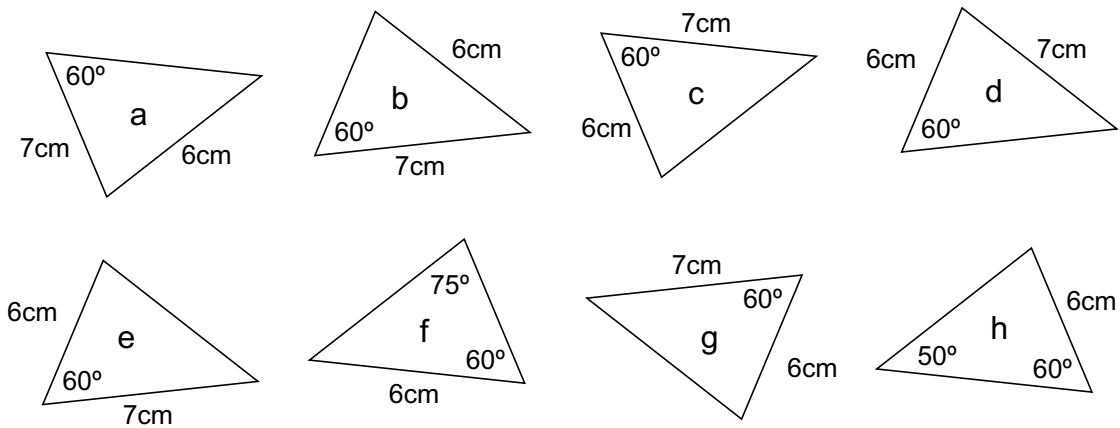

3)

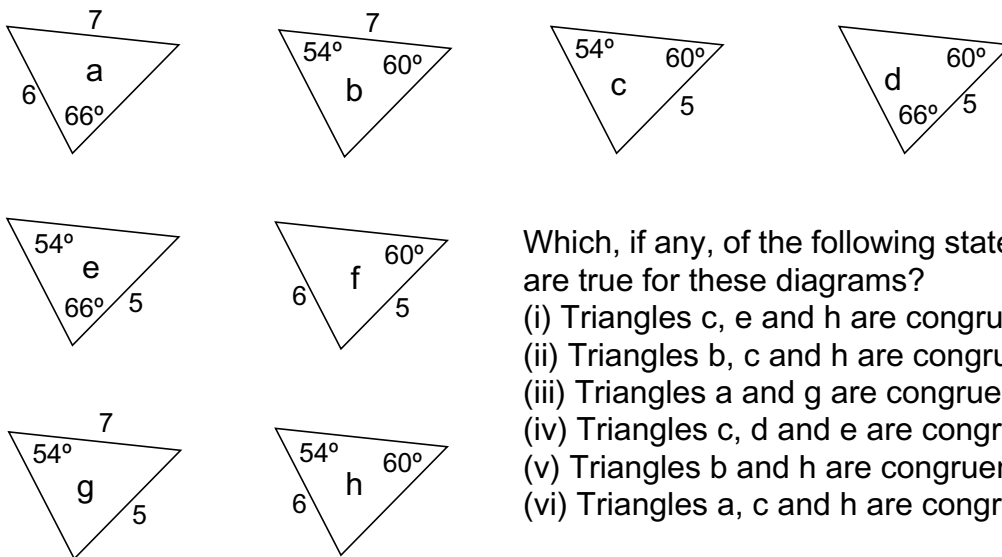

Which, if any, of the following statements are true for these diagrams?

- (i) Triangles c, e and h are congruent.
- (ii) Triangles b, c and h are congruent.
- (iii) Triangles a and g are congruent.
- (iv) Triangles c, d and e are congruent.
- (v) Triangles b and h are congruent.
- (vi) Triangles a, c and h are congruent.

Similar Triangles

L.8

1)

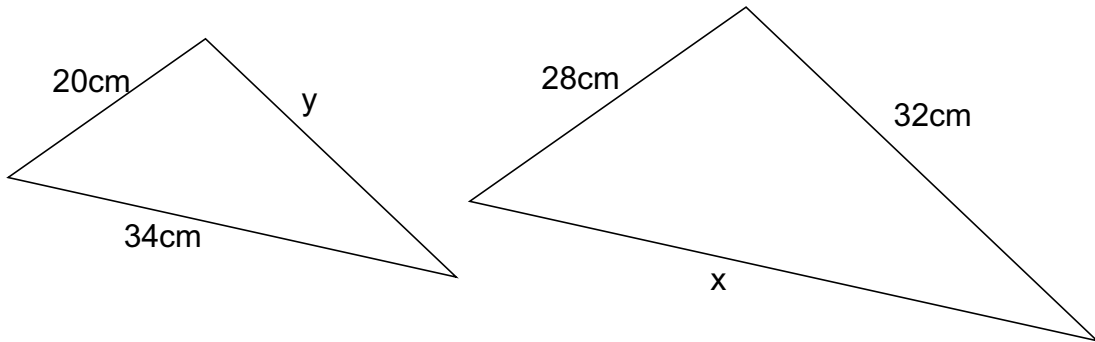

These triangles are similar. Calculate:-

- a) The length of x
- b) The length of y

2)

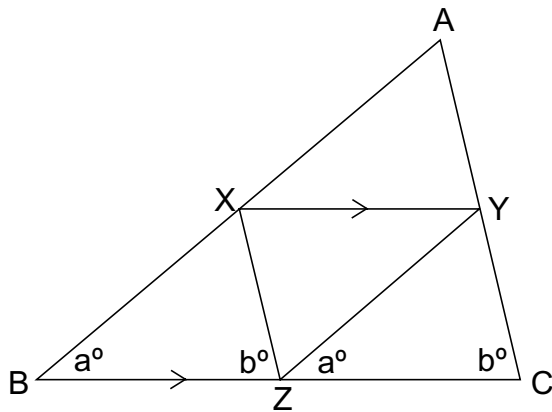

In the triangle ABC, XY is parallel to BC and half its length

- a) What is the size of angle ZXY?
- b) What is the size of angle XYZ?
- c) How many similar triangles are there in this diagram?
- d) If the length of AB is 300cm, what is the length of YZ?
- e) If the length of BZ is 140cm, what is the length of BC?

3)

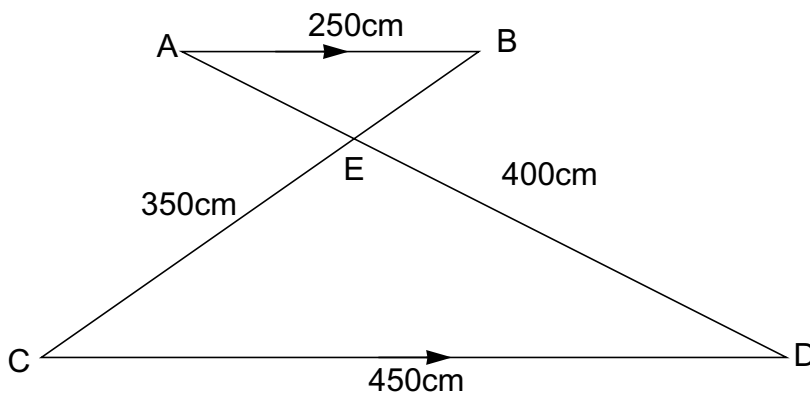

In this shape, AB is parallel to CD.

- a) Which angle is equal to angle ABE?
- b) Which angle is equal to angle ADC?
- c) Calculate the length of AE.
- d) Calculate the length of BE.

Angles

L.8

1)

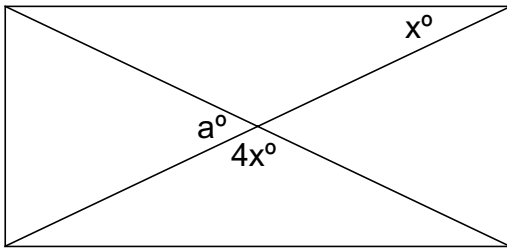

The diagram shows a rectangle with its diagonals. Two angles of x° and $4x^\circ$ are indicated. Calculate the size of the angle marked a° in terms of x .

2)

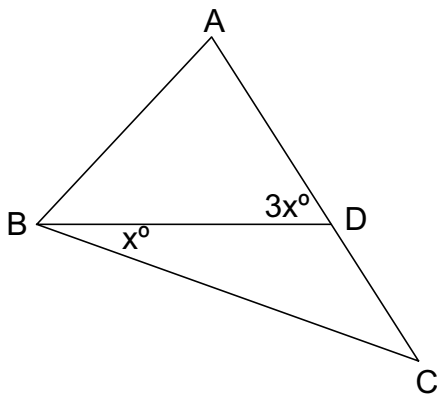

In this shape, $AC = BC$ and $AB = AD$. Two angles, x and $3x$ are marked. Calculate the size of angle x .

3)

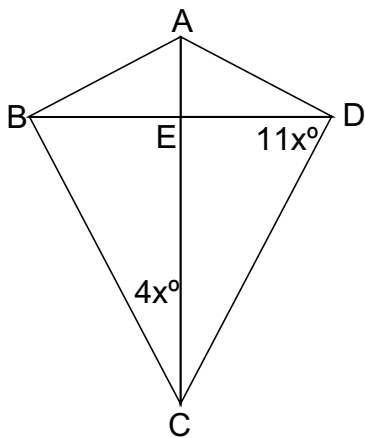

The diagram shows a kite $ABCD$. Triangle ABE is similar to triangle BEC . Two angles of size $4x^\circ$ and $11x^\circ$ are shown.
 a) Calculate the size of x .
 b) What are the sizes of the four angles of the kite?

4)

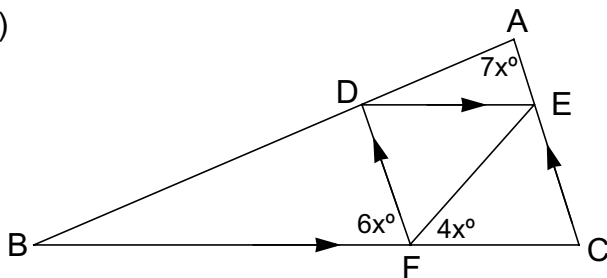

In the diagram, DE is parallel to BC and FD is parallel to CA . Three angles of $6x^\circ$ and $4x^\circ$ and $7x^\circ$ are shown. Angle EFC is twice angle DBF . Calculate the sizes of the angles of triangle DEF .

Sine, Cosine and Tangent Ratios

L.8

1) In each of the following right angled triangles, calculate the size of the unknown side x . Write down your answer correct to the nearest 0.1mm.

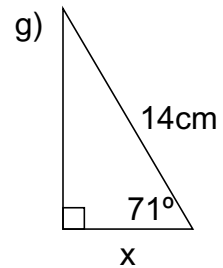
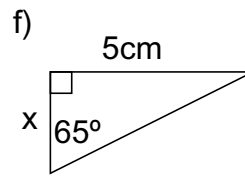
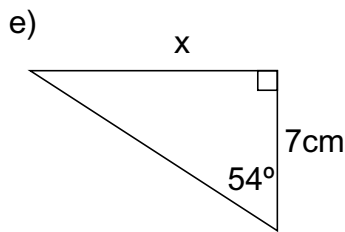
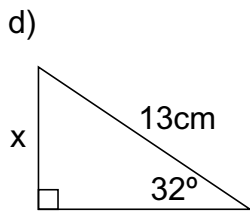
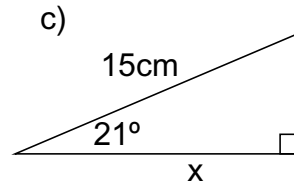
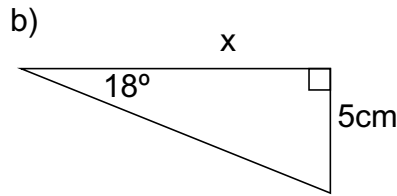
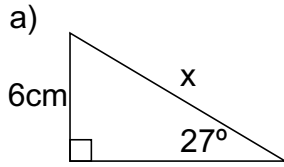

2) In each of the following right angled triangles, calculate the size of the unknown angle x . Write down your answer correct to the nearest 0.1°.

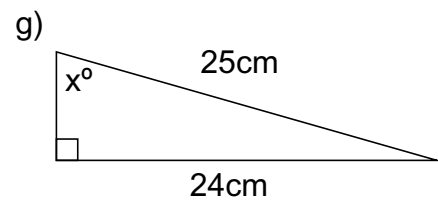
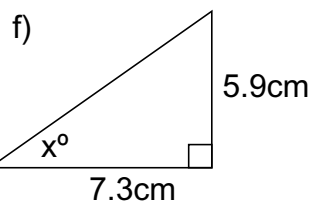
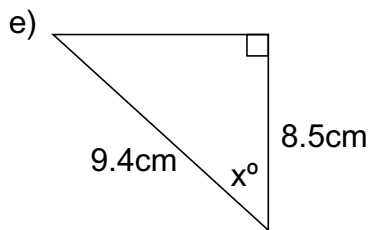
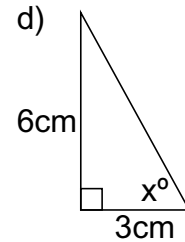
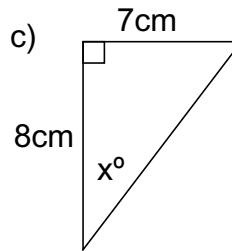
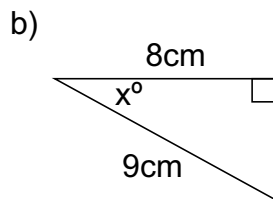
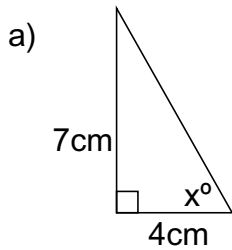

3)

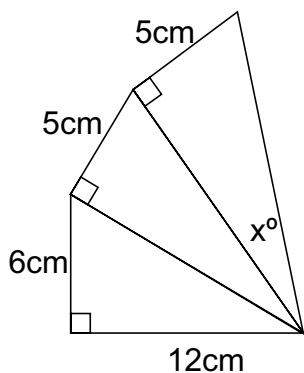

Calculate the size of the angle marked x .

Bearings

L.8

1) In the diagram below, calculate:-

- a) The bearing of Port Benon from the lighthouse.
- b) The bearing of the lighthouse from port Benon.

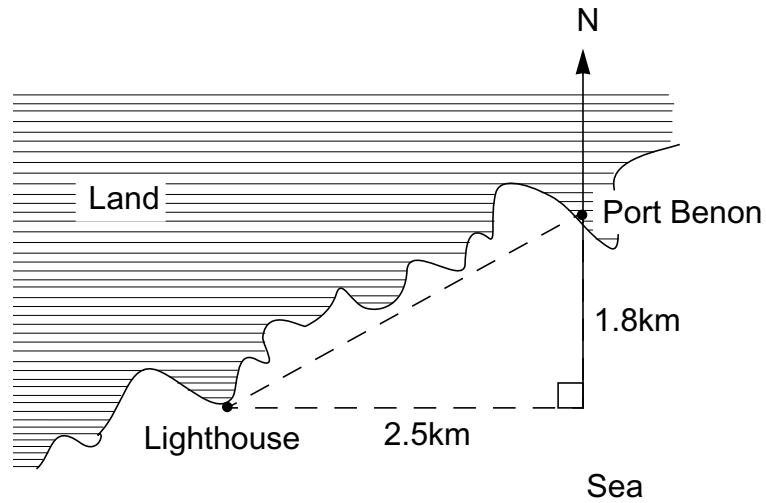

2) Baz stands on Angus Cliff and observes a ship and Regis Head through his binoculars.

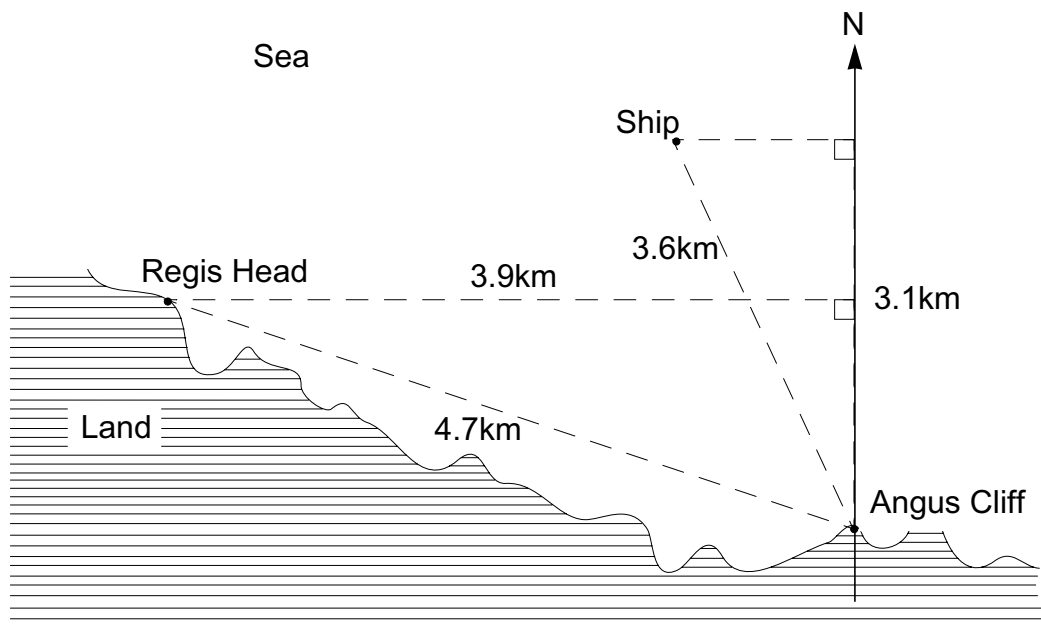

- a) What is the bearing of the ship from Angus Cliff?
- b) What is the bearing of Regis head from Angus Cliff?

Calculating Lengths in Triangles

L.8

1) The diagram below shows a kite.

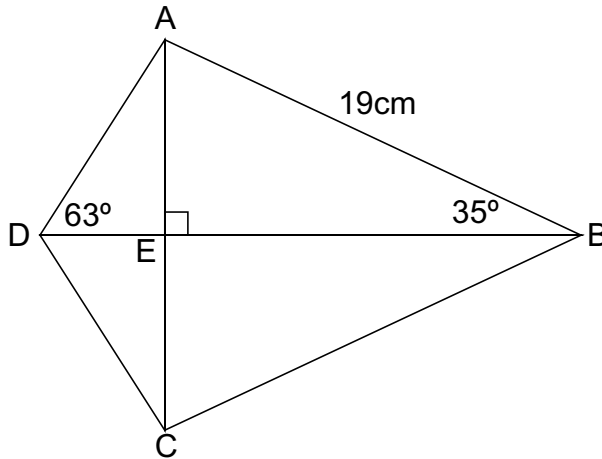

Calculate:-

- The length of EB.
- The length of AE.
- The length of DE.
- What are the lengths of its diagonals?

2) In the shape below, two right angled triangles ADB and DBC make a third right angled triangle ABC.

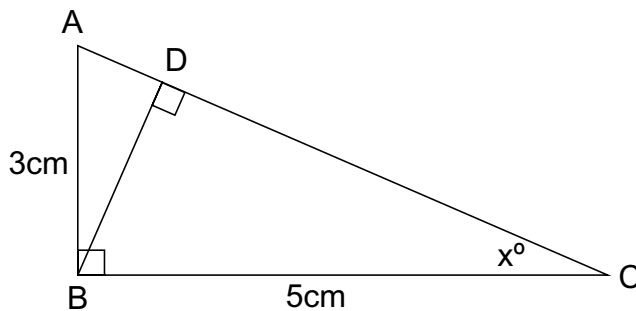

- Calculate the size of the angle marked x .
- What is the size of angle ABD?
- Calculate the length of AD.

3) The triangle ABC has two angles of 48° and 35° . Its height is 16cm. Calculate the length of its side BC.

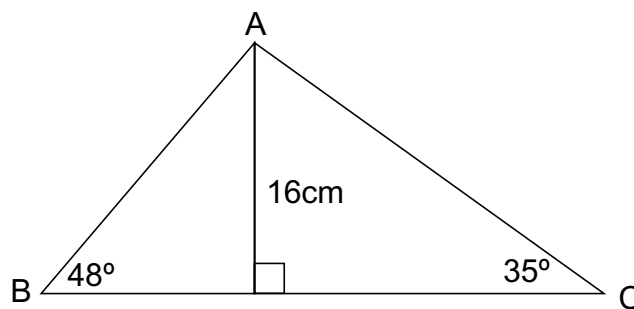

More Similarity

L.8

- 1) The diagram shows an equilateral triangle with sides measuring a cm. The perpendicular height of this triangle is h cm.

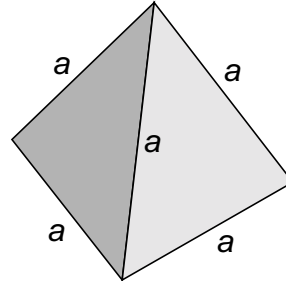
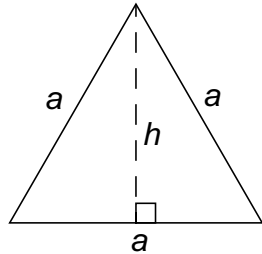

- Use your knowledge of Pythagoras' theorem to calculate the value of h in terms of a .
 - A tetrahedron is made from four of these triangles. What is the surface area of the tetrahedron in terms of a ?
 - A tetrahedron has edges of length 12cm. Calculate its surface area.
 - Another tetrahedron has edges of length $2a$ cms. What is the ratio of the surface area of the tetrahedron with sides of a cm to that of this larger one?
- 2) The diagram below shows two spheres, one with a radius of ' a 'cms and the other with a radius of ' $2a$ 'cms.

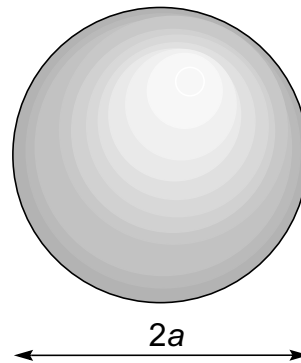
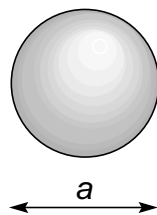

- The surface area of the smaller sphere is $A_s = \pi a^2$. What is the surface area, A_l , of the larger sphere?
- The volume of the smaller sphere is $V_s = \frac{1}{6} \pi a^3$.
Write down a formula for the volume V_l of the larger sphere.
- The diameter of a sphere is 24cms. Calculate its surface area and volume.
- The diameter of a small sphere is 2cm and that of a large sphere is 7cm. Explain why the ratio of their surface areas is 4 : 49.
- A sphere has a radius of 15cm and a larger sphere has a radius of 20cm. Explain why the ratio of their volumes is 27 : 64.

The Cricket Scores

L.8

- a) In the Barsetshire cricket league, the teams play two games a week for 20 weeks. The frequency table below shows the scores of Eggwold Cricket Club for 2001.

Runs Scored	Number of Games
> 50 and ≤ 100	1
> 100 and ≤ 150	3
> 150 and ≤ 200	11
> 200 and ≤ 250	17
> 250 and ≤ 300	6
> 300 and ≤ 350	2

Cumulative Frequency Graph

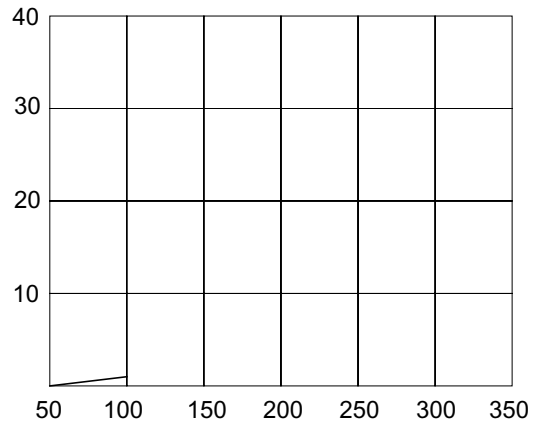

Copy and complete the cumulative frequency graph for Eggwold.

- b) The diagram below shows the cumulative frequency curve for Eggwold's arch rival Feldown. Use it to complete the frequency table for their scores.

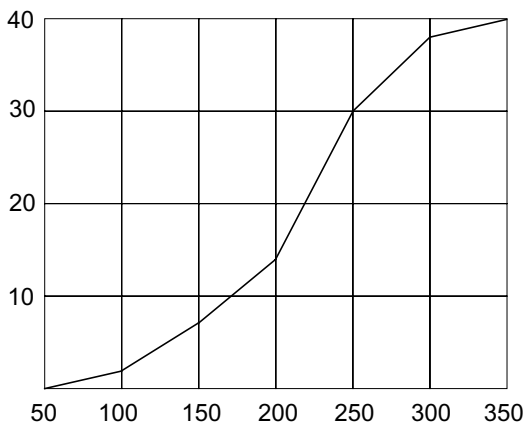

Runs Scored	Number of Games
> 50 and ≤ 100	2
> 100 and ≤ 150	
> 150 and ≤ 200	
> 200 and ≤ 250	
> 250 and ≤ 300	
> 300 and ≤ 350	

- c) Which team had the better median score?
- d) Calculate approximate values for the mean scores for both teams. Which team had the highest mean score?

Cumulative Frequency 1

L.8

1) The graph below shows the cumulative frequency distribution of the marks scored by 50 pupils in a mathematics examination. The marks are out of 100.

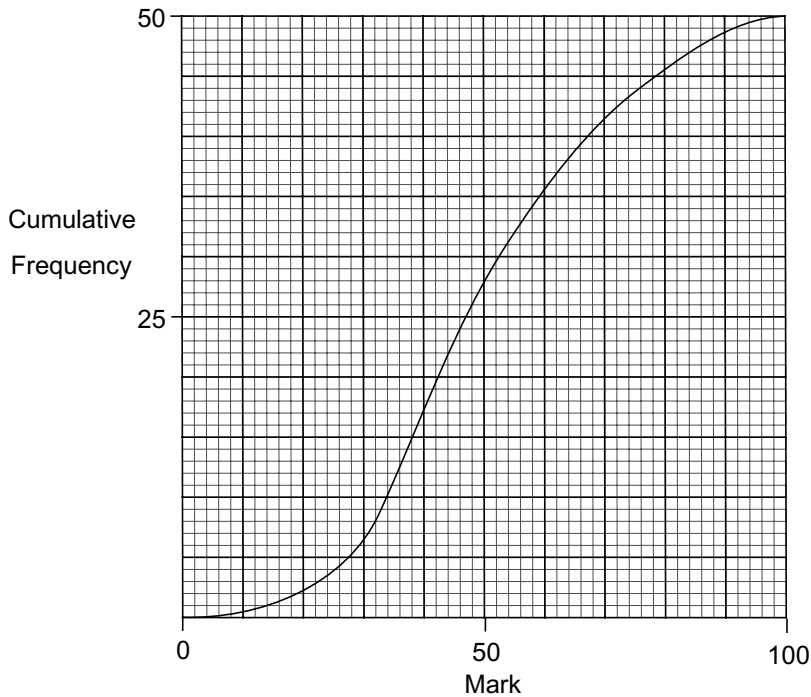

From the graph estimate the following

- What is the median mark?
- How many pupils got more than 40%?
- How many pupils got more than 59%?

2) The pupils in 9W were asked how much pocket money they were given each week. The results are shown on the frequency graphs below.

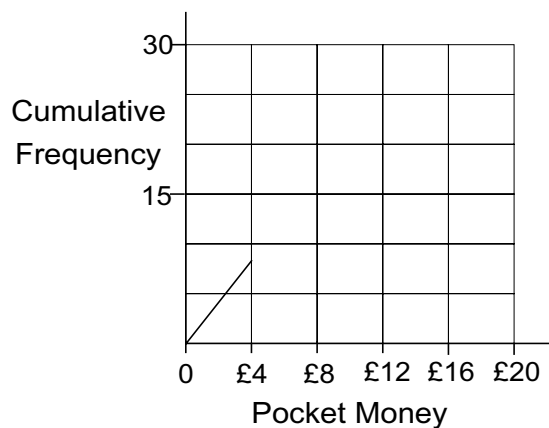
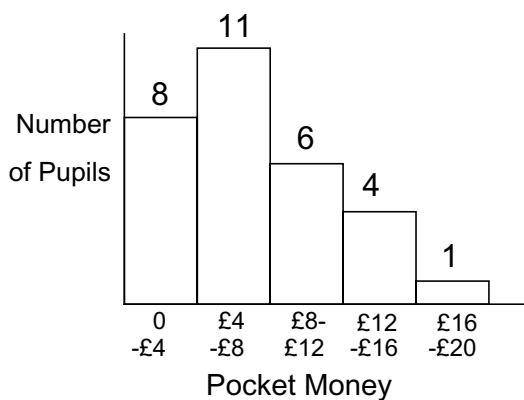

- Complete the cumulative frequency graph.
- Use the graph to estimate the median amount of pocket money the class gets.
- Estimate the percentage of pupils who get more than £10 per week.

Cumulative Frequency 2

L.8

1) The cumulative frequency graph shows the heights of 30 pupils in a class.

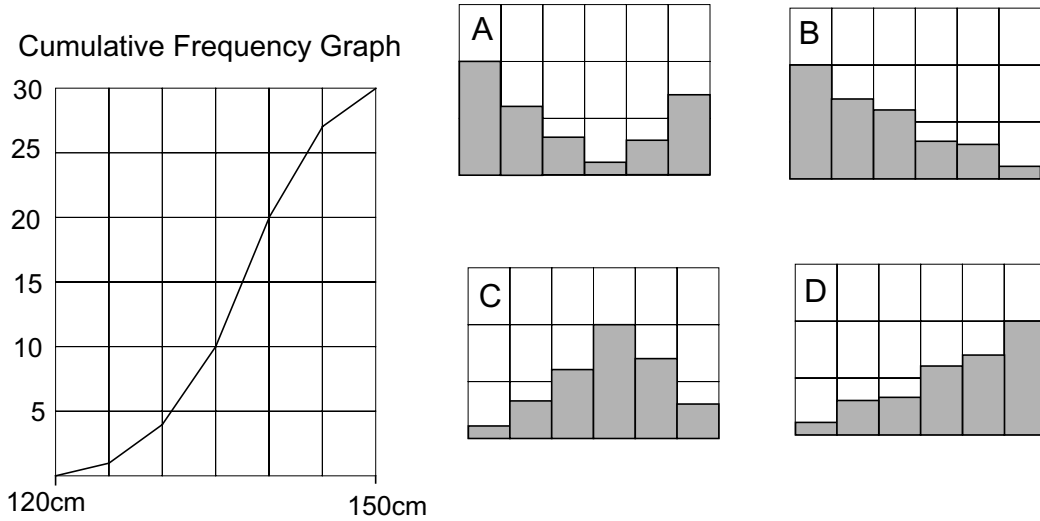

- Which of the four frequency graphs on the right shows this information?
- Draw a cumulative frequency graph for each of the other three frequency graphs.

2) The manufacturer of a new chemical fertiliser says that plants will produce at least 5% more fruit when fed on it.

They do an experiment to test this statement on two sets of plants.

One set they give the fertiliser to, but the second set they don't.

The diagram below shows cumulative frequency curves for the two sets of plants.

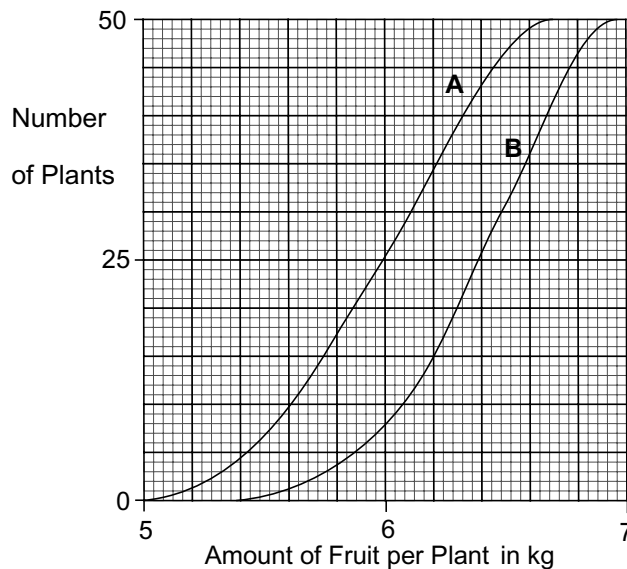

- Which graph, A or B, represents the plants which have had fertiliser?
- What is the median amount of fruit picked from each group of plants?
- What was the range of weights for each of the two groups?
- Do you think that they are justified in claiming a 5% increase in production? Explain your answer.

Cumulative Frequency 3

L.8

- 1) 100 pupils from year 9 were asked what time they got out of bed last Saturday morning. The results are shown in the tables below.

Table A

Time	Frequency
06:00 ≤ time < 07:00	2
07:00 ≤ time < 08:00	8
08:00 ≤ time < 09:00	23
09:00 ≤ time < 10:00	47
10:00 ≤ time < 11:00	20

Table B

	Cumulative Frequency
≤ 06:00	0
≤ 07:00	2
≤ 08:00	10
≤ 09:00	
≤ 10:00	
≤ 11:00	

- Use table A to show that the mean time they got out of bed was approximately 09:15
 - Complete the cumulative frequency table for the data.
 - Draw a cumulative graph for the data.
 - From your graph estimate the median time the pupils got out of bed.
- 2) A computer shop sells 70 different kinds of games. The frequency graph below shows their prices.

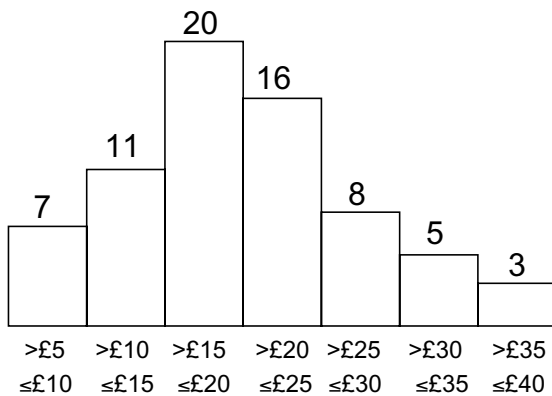

	Cumulative Frequency
≤ £5	0
≤ £10	7
≤ £15	18
≤ £20	
≤ £25	
≤ £30	
≤ £35	
≤ £40	

- Show that the mean price of a computer game in the shop is approximately £19.93
- Complete the cumulative frequency table for the data.
- Draw a cumulative frequency graph and from it estimate the median price of the computer games.

Probability 1

L.8

- 1) Tony has fair die. He rolls it and records the result.
- What is the probability of him getting a 3 when he rolls it once?
 - What is the probability of him getting two 3's when he rolls it twice?
 - What is the probability of him getting three 3's when he rolls it three times?
 - What is the probability of him getting a 2 followed by a 1 when he rolls it twice?
 - What is the probability of him not getting a 4 when he rolls it twice?

- 2) I have two bags containing coloured discs.

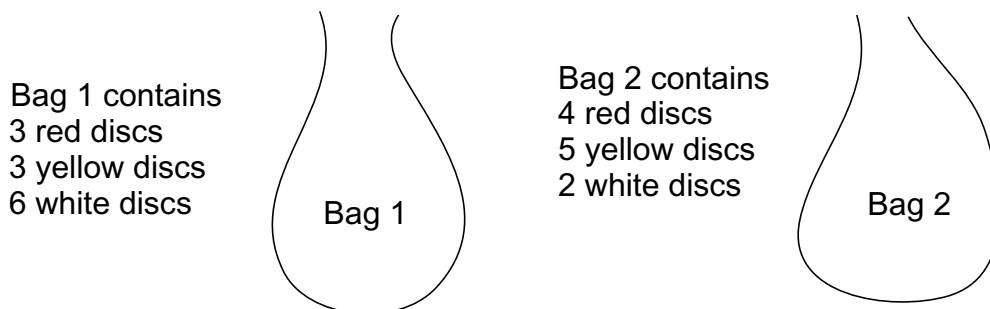

Discs are withdrawn from the bags.

- What is the probability of withdrawing a yellow disc from bag 1?
 - What is the probability of withdrawing a yellow disc from bag 2?
- c) I withdraw two discs, one from bag 1 and one from bag 2. Which of the calculations below shows the probability of getting a white disc followed by a red disc?
- | | | | |
|------------------------------------|-------------------------------|------------------------------------|-------------------------------|
| $\frac{2}{11} \times \frac{1}{22}$ | $\frac{2}{11} + \frac{1}{22}$ | $\frac{6}{12} \times \frac{4}{11}$ | $\frac{6}{12} + \frac{4}{11}$ |
|------------------------------------|-------------------------------|------------------------------------|-------------------------------|
- d) Chen takes a disc from bag 1 then a disc from bag 2. What is the probability that he takes a yellow disc each time?
- 3) In 7D there are 14 boys and 12 girls. In 7F there are 13 boys and 15 girls. Two people are to be chosen at random by the head of year, one from each group.
- What is the probability that they are both boys?
 - What is the probability that they are both girls?
 - What is the probability that one boy and one girl are chosen?
- 4) At the inter-schools athletics meeting, Goma is entered for the 200 metres and the high jump finals. She knows from past experience that her chance of winning the 200 metres is 0.6 and her chance of winning the high jump is 0.3.
- What is her chance of winning both events?
 - What is her chance of winning just the high jump?
 - What is her chance of winning just the 200 metres?
 - What is her chance of winning at least one of the events?

Probability 2

L.8

- 1) In a class of 28 pupils, some have brothers, some have sisters, some have both and some have neither. The diagram below shows this. There are 7 pupils who have both brothers and sisters.

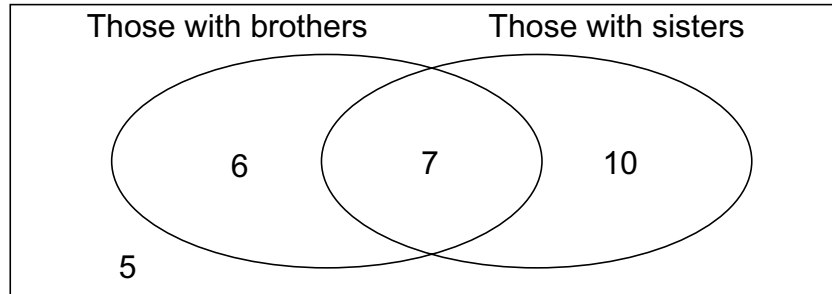

- a) How many pupils have a brother?
 b) What is the probability that a pupil, chosen at random, will have a brother?
 c) What is the probability that a pupil, chosen at random, will have a sister?
 d) What is the probability that a pupil, chosen at random, will not have a brother or a sister?
 e) What is the probability that a pupil who has a brother also has a sister?
- 2) In order to get from her home to her Grans, Ciana has to catch two busses. She knows that when she waits for a bus at the first stop there is a probability of 0.7 that she will have to wait more than 5 minutes. At the second stop, the probability is 0.2.
- a) Calculate the probability that she will have to wait more than 5 minutes at both stops.
 b) She visits her Gran every Saturday for 50 weeks. How many times would you expect her to wait for both buses for more than 5 minutes each?
- 3) George has a biased die. He calculates that the probability of getting a 1, 2 or 3 are each 0.2.
- a) The probability of him getting a 1 followed by a 4 is 0.03. What is the probability of him getting a 4 with one roll of the die?
 b) What is the probability of getting a 5 if it is the same as the probability of getting a 6?
- 4) Six cards have the numbers 1 to 6 written on them.

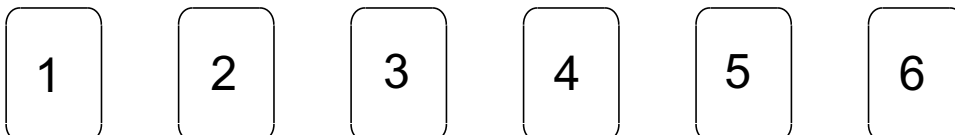

The cards are shuffled and placed face down on a table, one on top of the other. Calculate the following probabilities.

- a) The top card has a 1 on it.
 b) The top card is a 1 and the next card is a 2.
 c) The top two cards are 1 and 2 in any order.

