

Contents.

Adding	7
Subtracting	8
Negative Numbers	9
Fractional Parts	10
Equivalent Fractions	11
Approximation	12
Number Chains	13
Money Problems	14
Rules	15
Triangular Dots	16
Angles	17
Turning	18
Similar Shapes	19
Fitting Shapes	20
Reflection Symmetry	21
3 Dimensional Symmetry	22
Measurements	23
Reading Scales	24
Time Intervals	25
Paving Stones	26
Information	27
Reading Tables	28
Information Tables	29
Calendar	30
Using Information	31
Pictograms	32
Bar charts	33
Charts and Pictograms	34
Frequency Tables	35
Putting Data into Tables	36
Adding Decimals	37
Subtracting Decimals	38
Multiplying	39
Dividing	40
Writing Fractions	41
Percentages	42
Mixing	43
Multiplication Tables	44
Combining Multiplication Tables	45
Missing Numbers	46
Number lines	47
Putting Numbers into Order	48
Magic Squares	49
Making Numbers	50
Comparing	51
Chain Rules	52
Mental Arithmetic	53

Tests for Dividing	54
Tens, Hundreds and Whole Numbers	55
Tens, Hundreds and Decimals	56
Position	57
Co-ordinates	58
Number Patterns	59
Number Machines	60
Angles Between	61
Turning Patterns	62
Reflections	63
Rotation	64
Volume of a Cuboid	65
Volume of a Shape	66
Packing Boxes	67
Area and Perimeter	68
Measuring Lines	69
Measuring Instruments	70
Measuring Lengths	71
Adding Time	72
Making Areas	73
Years	74
Bars	75
Clothes Sizes	76
Book Prices	77
Mode and Range	78
Describing Data	79
Rainfall Graph	80
Second-hand Cars	81
Train Fares	82
Probability	83

Adding

Do not use a calculator

L.3

1) Add together each of the following pairs of numbers.

a)

$$\begin{array}{r} 26 \\ +34 \\ \hline \end{array}$$

b)

$$\begin{array}{r} 53 \\ + 5 \\ \hline \end{array}$$

c)

$$\begin{array}{r} 46 \\ +29 \\ \hline \end{array}$$

d)

$$\begin{array}{r} 45 \\ +56 \\ \hline \end{array}$$

e)

$$\begin{array}{r} 43 \\ +34 \\ \hline \end{array}$$

f)

$$\begin{array}{r} 29 \\ +86 \\ \hline \end{array}$$

g)

$$\begin{array}{r} 63 \\ +98 \\ \hline \end{array}$$

h)

$$\begin{array}{r} 34 \\ +94 \\ \hline \end{array}$$

i)

$$\begin{array}{r} 76 \\ +91 \\ \hline \end{array}$$

j)

$$\begin{array}{r} 72 \\ +76 \\ \hline \end{array}$$

k) $46 + 25$

l) $94 + 31$

m) $87 + 76$

n) $47 + 34$

o) $39 + 87$

p) $65 + 6$

q) $43 + 76$

r) $72 + 93$

2) Add together each of the following pairs of numbers.

a)

$$\begin{array}{r} 364 \\ + 76 \\ \hline \end{array}$$

b)

$$\begin{array}{r} 23 \\ +476 \\ \hline \end{array}$$

c)

$$\begin{array}{r} 673 \\ + 37 \\ \hline \end{array}$$

d)

$$\begin{array}{r} 285 \\ + 85 \\ \hline \end{array}$$

e)

$$\begin{array}{r} 754 \\ + 65 \\ \hline \end{array}$$

f)

$$\begin{array}{r} 145 \\ + 93 \\ \hline \end{array}$$

g)

$$\begin{array}{r} 54 \\ +123 \\ \hline \end{array}$$

h)

$$\begin{array}{r} 453 \\ +326 \\ \hline \end{array}$$

i)

$$\begin{array}{r} 472 \\ +437 \\ \hline \end{array}$$

j)

$$\begin{array}{r} 38 \\ +746 \\ \hline \end{array}$$

k) $34 + 674$

l) $53 + 534$

m) $764 + 43$

n) $439 + 543$

o) $385 + 185$

p) $364 + 549$

q) $28 + 798$

r) $784 + 19$

3) Add together each of the following.

a)

$$\begin{array}{r} 34 \\ 356 \\ + 6 \\ \hline \end{array}$$

b)

$$\begin{array}{r} 32 \\ 7 \\ +468 \\ \hline \end{array}$$

c)

$$\begin{array}{r} 2 \\ 35 \\ +572 \\ \hline \end{array}$$

d)

$$\begin{array}{r} 25 \\ 6 \\ + 365 \\ \hline \end{array}$$

e)

$$\begin{array}{r} 5 \\ 47 \\ 84 \\ + 568 \\ \hline \end{array}$$

f)

$$\begin{array}{r} 754 \\ 17 \\ 23 \\ +475 \\ \hline \end{array}$$

g)

$$\begin{array}{r} 3 \\ 43 \\ 476 \\ +274 \\ \hline \end{array}$$

h)

$$\begin{array}{r} 3 \\ 154 \\ 75 \\ + 547 \\ \hline \end{array}$$

i)

$$\begin{array}{r} 475 \\ 34 \\ 263 \\ +367 \\ \hline \end{array}$$

j)

$$\begin{array}{r} 375 \\ 435 \\ 274 \\ + 37 \\ \hline \end{array}$$

k) $6 + 13 + 342$

l) $34 + 476 + 3$

m) $45 + 723 + 43$

n) $34 + 786 + 543$

o) $34 + 67 + 549 + 197$

p) $65 + 7 + 354 + 85$

Subtracting

Do not use a calculator

L.3

1) Subtract the following pairs of numbers.

$$\begin{array}{r} \text{a)} \\ 27 \\ - 4 \\ \hline \end{array}$$

$$\begin{array}{r} \text{b)} \\ 39 \\ - 6 \\ \hline \end{array}$$

$$\begin{array}{r} \text{c)} \\ 43 \\ - 12 \\ \hline \end{array}$$

$$\begin{array}{r} \text{d)} \\ 56 \\ - 24 \\ \hline \end{array}$$

$$\begin{array}{r} \text{e)} \\ 67 \\ - 45 \\ \hline \end{array}$$

$$\begin{array}{r} \text{f)} \\ 12 \\ - 9 \\ \hline \end{array}$$

$$\begin{array}{r} \text{g)} \\ 24 \\ - 17 \\ \hline \end{array}$$

$$\begin{array}{r} \text{h)} \\ 36 \\ - 29 \\ \hline \end{array}$$

$$\begin{array}{r} \text{i)} \\ 53 \\ - 37 \\ \hline \end{array}$$

$$\begin{array}{r} \text{j)} \\ 72 \\ - 34 \\ \hline \end{array}$$

$$\text{k) } 38 - 12$$

$$\text{l) } 45 - 22$$

$$\text{m) } 65 - 34$$

$$\text{n) } 56 - 32$$

$$\text{o) } 84 - 54$$

$$\text{p) } 45 - 39$$

$$\text{q) } 84 - 56$$

$$\text{r) } 67 - 39$$

$$\text{s) } 93 - 27$$

$$\text{t) } 82 - 56$$

$$\text{u) } 76 - 63$$

$$\text{v) } 34 - 19$$

2) Subtract the following pairs of numbers.

$$\begin{array}{r} \text{a)} \\ 125 \\ - 3 \\ \hline \end{array}$$

$$\begin{array}{r} \text{b)} \\ 243 \\ - 11 \\ \hline \end{array}$$

$$\begin{array}{r} \text{c)} \\ 187 \\ - 54 \\ \hline \end{array}$$

$$\begin{array}{r} \text{d)} \\ 385 \\ - 126 \\ \hline \end{array}$$

$$\begin{array}{r} \text{e)} \\ 956 \\ - 546 \\ \hline \end{array}$$

$$\begin{array}{r} \text{f)} \\ 120 \\ - 6 \\ \hline \end{array}$$

$$\begin{array}{r} \text{g)} \\ 240 \\ - 23 \\ \hline \end{array}$$

$$\begin{array}{r} \text{h)} \\ 365 \\ - 47 \\ \hline \end{array}$$

$$\begin{array}{r} \text{i)} \\ 485 \\ - 347 \\ \hline \end{array}$$

$$\begin{array}{r} \text{j)} \\ 475 \\ - 339 \\ \hline \end{array}$$

$$\begin{array}{r} \text{k)} \\ 648 \\ - 179 \\ \hline \end{array}$$

$$\begin{array}{r} \text{l)} \\ 850 \\ - 176 \\ \hline \end{array}$$

$$\begin{array}{r} \text{m)} \\ 532 \\ - 487 \\ \hline \end{array}$$

$$\begin{array}{r} \text{n)} \\ 930 \\ - 862 \\ \hline \end{array}$$

$$\begin{array}{r} \text{o)} \\ 700 \\ - 287 \\ \hline \end{array}$$

$$\text{p) } 438 - 7$$

$$\text{q) } 583 - 32$$

$$\text{r) } 745 - 34$$

$$\text{s) } 673 - 24$$

$$\text{t) } 642 - 29$$

$$\text{u) } 274 - 38$$

$$\text{v) } 748 - 256$$

$$\text{w) } 496 - 159$$

- 3) There are 156 pupils in year 8. If 72 of them are girls, how many are boys?
- 4) A box contains 150 apples. If 27 are removed, how many are left?
- 5) There are seats for 56 people on a bus. If there are 73 people on the bus, how many are without a seat?
- 6) The distance from Claire's home to London is 254 miles. How many miles are left when she has travelled 145 miles?
- 7) A piece of wood measures 240 centimetres. Angela cuts it into 2 pieces. If one piece measures 159cm what is the length of the second piece?
- 8) A shopkeeper has a stock of 253 books. If she sells 169 of them, how many will she have left?

Negative Numbers

L.3

- 1) The school thermometer reads -4°C at 9 o'clock in the morning.
At Lunchtime it reads -1°C .
At 3 o'clock in the afternoon it reads -5°C .
- At what time of the day was it warmest?
 - At what time of the day was it coldest?

2)

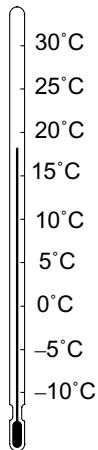

The diagram shows a thermometer. It shows a temperature of 18°C .

Use the diagram to answer these questions.

- What is the lowest temperature shown?
- What is the hottest temperature shown?
- What is the coldest temperature shown?
- Which temperature is the warmer, 5°C or -10°C ?

3)

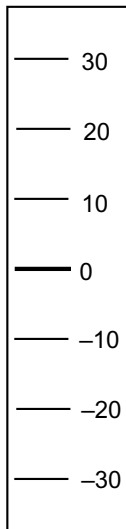

The diagram shows a board to measure the height of the river. It is fixed to the river bank.

The normal height of the river is 0 feet

In the Autumn floods the river reached point A. In the Summer the river reached point B.

Fill in the blanks in these sentences.

- In Autumn the height of the river was about feet above normal.
- In Summer the height of the river was about feet below normal.

- 4) A video tape has a running time of 6 hours. Half way through the tape the counter on the recorder is set to zero, 0:00. If it is now run to the beginning of the tape, the counter shows $-3:00$. When it is run to the end of the tape, the counter shows 3:00.

What will the counter read in each of the following positions?

- 1 hour from the start of the tape.
- 1 hour from the end of the tape.
- 30 minutes from the end of the tape.
- Two and a half hours from the beginning of the tape.

Fractional Parts

L.3

1) Say what fraction of these diagrams is shaded in.

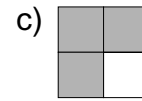
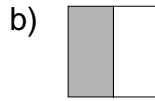
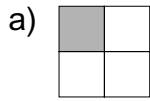

2) Point X is half way along the line.

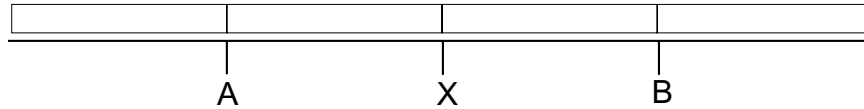

- a) How far along the line is A?
- b) How far along the line is B?

3) Point X is half way along the line.

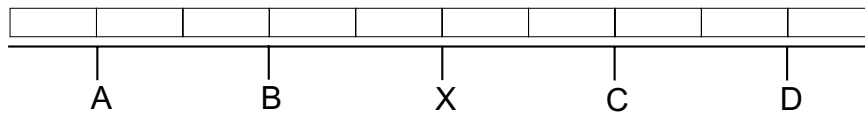

- a) How far along the line is point A?
- b) How far along the line is point B?
- c) How far along the line is point C?
- d) How far along the line is point D?

4) Point A is one fifth of the way along this line.

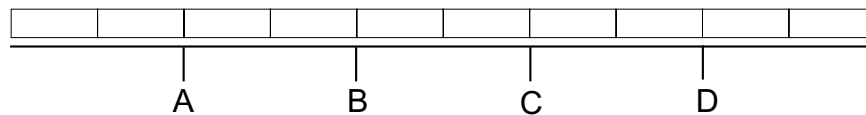

How far along the line are the other points?

5) Say what fraction of these shapes has been shaded in.

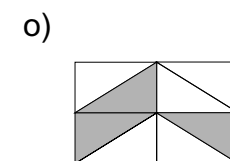
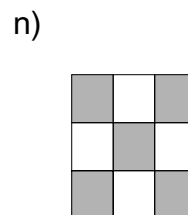
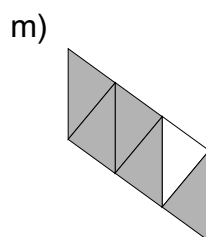
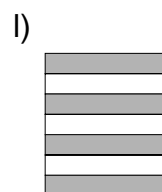
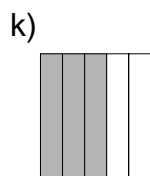
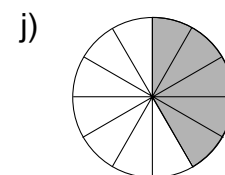
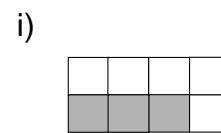
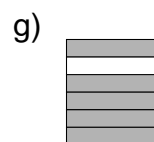
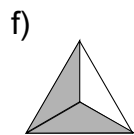
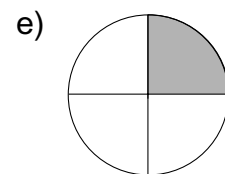
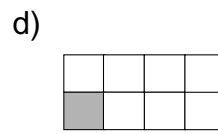
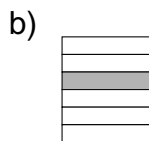
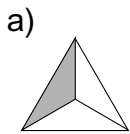

Equivalent Fractions

L.3

1) Which of the fractions below are the same size as $\frac{1}{2}$?

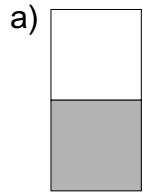

$$\frac{1}{2}$$

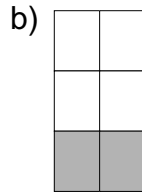

$$\frac{2}{6}$$

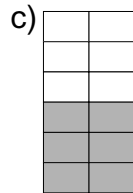

$$\frac{6}{12}$$

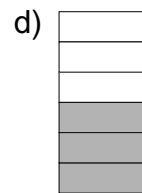

$$\frac{3}{6}$$

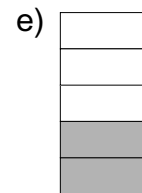

$$\frac{2}{5}$$

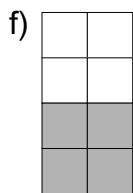

$$\frac{4}{8}$$

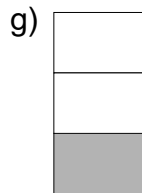

$$\frac{1}{3}$$

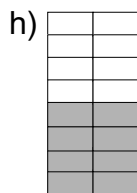

$$\frac{8}{16}$$

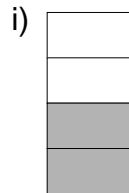

$$\frac{2}{4}$$

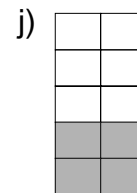

$$\frac{4}{10}$$

2) Which of these fractions is equivalent to $\frac{1}{3}$?

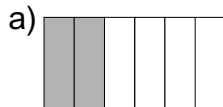

$$\frac{2}{6}$$

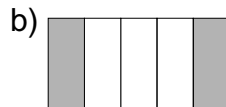

$$\frac{2}{5}$$

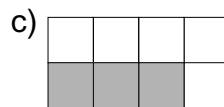

$$\frac{3}{8}$$

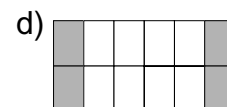

$$\frac{4}{12}$$

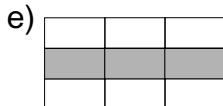

$$\frac{3}{9}$$

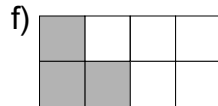

$$\frac{3}{8}$$

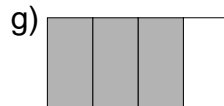

$$\frac{3}{4}$$

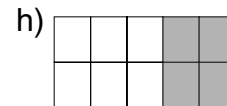

$$\frac{4}{10}$$

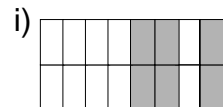

$$\frac{6}{16}$$



$$\frac{1}{2}$$

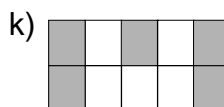

$$\frac{5}{10}$$

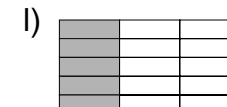

$$\frac{5}{15}$$

3) Which of these fractions are equivalent to $\frac{3}{4}$?

- a) $\frac{1}{3}$, b) $\frac{6}{8}$, c) $\frac{4}{9}$, d) $\frac{5}{7}$, e) $\frac{12}{16}$, f) $\frac{10}{12}$, g) $\frac{6}{10}$, h) $\frac{9}{12}$, i) $\frac{3}{5}$, j) $\frac{7}{11}$, k) $\frac{4}{6}$

Approximations

Do not use a calculator

L.3

- 1) In each of the following, say what the value of the 6 is.
a) 26 b) 136 c) 560 c) 164 d) 654 e) 761 f) 436
- 2) In each of the following, say what the value of the 1 is.
a) 10 b) 210 c) 601 d) 186 e) 551 f) 910 g) 619
- 3) There are 174 pupils in year 7.
Nick says "There are about 180 pupils in year 7"
Helen says "There are about 170 pupils in year 7"
Who is correct and why?
- 4) David and Alice estimate the number of pupils in the school assembly. They count up the number of rows of seats and the number of seats in each row. Not every seat has someone sitting on it and there are some pupils standing.
Alice says "I think there are about 250"
David says "I think there are about 220"
After assembly they find out that there were 239 pupils. Who gave the closest estimate?
- 5) In the school hall there are 25 rows of seats. Each row has 20 seats in it.
 - a) Calculate how many seats there are altogether.
 - b) On Tuesday evening at the school production there are some seats left empty.
Which of these statements could be true?
 - (i) "There are 500 people at the production"
 - (ii) "There are less than 500 people at the production"
 - (iii) "There are about 480 people at the production"
 - (iv) "There are more than 500 people at the production"
 - (v) "There are more than 400 people at the production"
 - c) On Friday evening all the seats are taken and there are some people standing up.
Write down three statements which could be true to describe the number of people at the production.
- 6) Catherine estimates that there are about 750 people at the school football match. A bus arrives with some more spectators. Sian says "The bus is full so there must be about 60 people on it". If Sian is correct, which of the following statements are correct?
 - (i) "There are now about 800 people at the football match"
 - (ii) "There are now about 810 people at the football match"
 - (iii) "There are now more than 800 people at the football match"
 - (iv) "There are now exactly 810 people at the football match"

Number Chains

Do not use a calculator

L.3

In each of the following number chains, write down the next two numbers and say what the rule is.

a) $2 \rightarrow 4 \rightarrow 6 \rightarrow 8 \rightarrow 10 \rightarrow$

b) $5 \rightarrow 10 \rightarrow 15 \rightarrow 20 \rightarrow 25 \rightarrow$

c) $1 \rightarrow 3 \rightarrow 5 \rightarrow 7 \rightarrow 9 \rightarrow$

d) $0 \rightarrow 3 \rightarrow 6 \rightarrow 9 \rightarrow 12 \rightarrow$

e) $2 \rightarrow 5 \rightarrow 8 \rightarrow 11 \rightarrow 14 \rightarrow$

f) $1 \rightarrow 6 \rightarrow 11 \rightarrow 16 \rightarrow 21 \rightarrow$

g) $1 \rightarrow 2 \rightarrow 4 \rightarrow 8 \rightarrow 16 \rightarrow$

h) $1 \rightarrow 3 \rightarrow 9 \rightarrow 27 \rightarrow 81 \rightarrow$

i) $1 \rightarrow 1 \rightarrow 2 \rightarrow 3 \rightarrow 5 \rightarrow$

j) $1 \rightarrow 2 \rightarrow 4 \rightarrow 7 \rightarrow 11 \rightarrow$

k) $5 \rightarrow 3 \rightarrow 1 \rightarrow -1 \rightarrow -3 \rightarrow$

l) $5 \rightarrow 2 \rightarrow -1 \rightarrow -4 \rightarrow -7 \rightarrow$

m) $-9 \rightarrow -7 \rightarrow -5 \rightarrow -3 \rightarrow -1 \rightarrow$

n) $-8 \rightarrow -6 \rightarrow -4 \rightarrow -2 \rightarrow 0 \rightarrow$

o) $-20 \rightarrow -17 \rightarrow -14 \rightarrow -11 \rightarrow -8 \rightarrow$

p) $7 \rightarrow 3 \rightarrow -1 \rightarrow -5 \rightarrow -9 \rightarrow$

q) $8 \rightarrow 4 \rightarrow 2 \rightarrow 1 \rightarrow \frac{1}{2} \rightarrow$

Money Problems

L.3

- 1) Jenny goes to the local shop. She buys a bottle of milk for 42p, a comic for 48p and a packet of sweets for 62p.
 - a) How much did she spend altogether?
 - b) She paid with a £2 coin. How much change did she get?

- 2) In the supermarket a loaf of bread costs 37p. How many loaves can David buy with a £2 coin? How much money will be left over?

- 3) The single train fare from Gary's home into the centre of town is £1.90. The single train fare from town back to Gary's is also £1.90.
 - a) How much does Gary pay altogether if he goes to town and back?
The next week Gary buys a return fare for £3.20. This gets Gary into town and back out again.
 - b) If he pays with a £10 note what change will he get?
 - c) He says "It is cheaper to buy a return ticket than two single tickets". How much will he save by buying a return?

- 4) Graham writes out a cheque for sixty three pounds and sixteen pence. How did he write this amount in figures?

- 5) Abigail has to write a cheque. She writes the amount in words 'Three hundred and fifty six pounds, twenty four pence'. Write down this amount in figures.

- 6) Susan has £10.25. She wants to buy 5 Christmas presents. She spends the same amount of money on each present. How much does she spend on each present?

- 7) Paula buys cinema tickets. They cost £5.50 each. How many can she buy with a £20 note, and how much money will be left over?

- 8) How many chocolate bars costing 27p each can be bought for £5? How much money will be left over?

- 9) Ranjit goes to the cinema. He buys a ticket for £4.25 and popcorn for £1.30. His bus fare costs £1.40 and he buys a drink for 76p when he leaves the cinema. If he leaves home with a £10 note, how much change does he return with?

- 10) Eileen goes to the supermarket. She buys 4 tins of beans costing 32p each, 7 oranges costing 18p each, 2 packets of frozen peas costing 78p each and 3 bottles of cola costing 45p each.
 - a) What was the total cost of these items?
 - b) In her purse she had a £10 note, one £2 coin, four £1 coins, three 20p coins and four 5p coins. If she gave the correct money, which coins did she use?

Rules

L.3

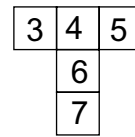
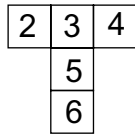
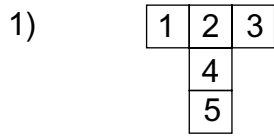

Complete the numbers in these T shapes

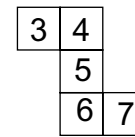
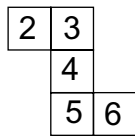
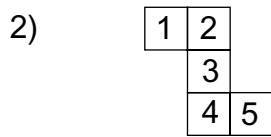
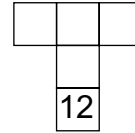
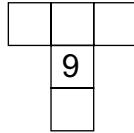
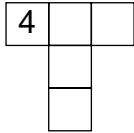

Complete the numbers in these shapes

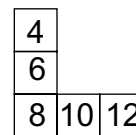
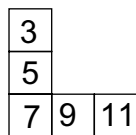
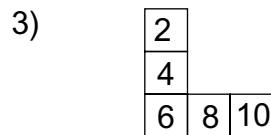
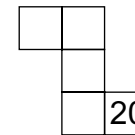
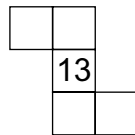
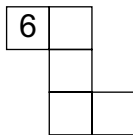

Complete the numbers in these shapes

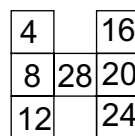
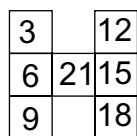
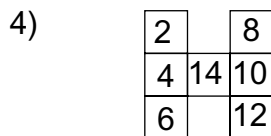
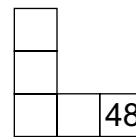
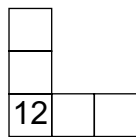
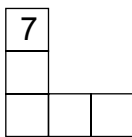

Complete the numbers in these shapes

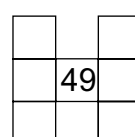
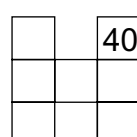
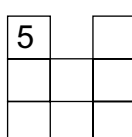

Triangular Dots

L.3

You will need triangular spotty paper for this work

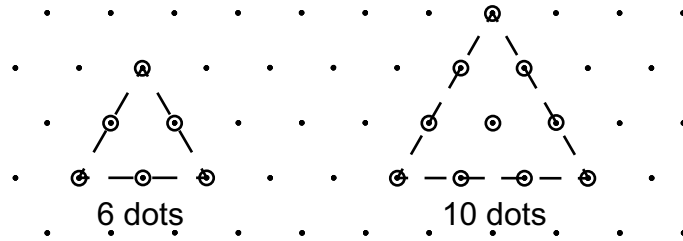

On triangular spotty paper, Ben puts a circle around some of the dots.
 If he circles 6 dots he gets a triangle.
 If he circles 10 dots he gets a bigger triangle.
 6 is called a triangular number.
 10 is called a triangular number.

On triangular spotty paper, make up some more triangles.
 What other triangular numbers are there?
 Remember to include all the dots inside the triangle.

- 1) a) What is the smallest triangular number you can find?
- b) Is 4 a triangular number?
- c) Is 16 a triangular number?
- d) Is 21 a triangular number?

Triangular numbers can be calculated like this

$$1 + 2 + 3 = 6$$

$$1 + 2 + 3 + 4 = 10$$

and so on

- 2) Use this rule to calculate all the triangular numbers smaller than 100.

Marc decides to make some triangles without the dots on the inside.

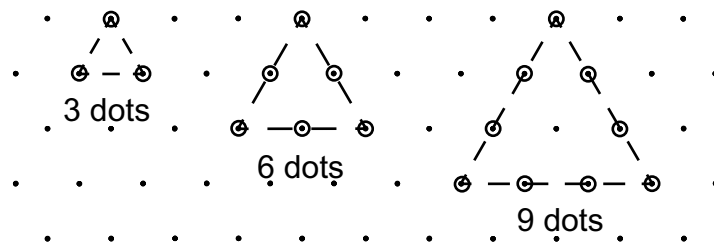

Draw some more of these shapes

- 3) a) Can one of these triangles be made from 16 dots?
- b) Can one of these triangles be made from 21 dots?
- c) Can one of these triangles be made from 30 dots?
- d) What kind of number will make these triangles?

Angles

L.3

1) There are 8 angles shown below. Write down the angles in order of size. Start with the smallest and end with the largest.

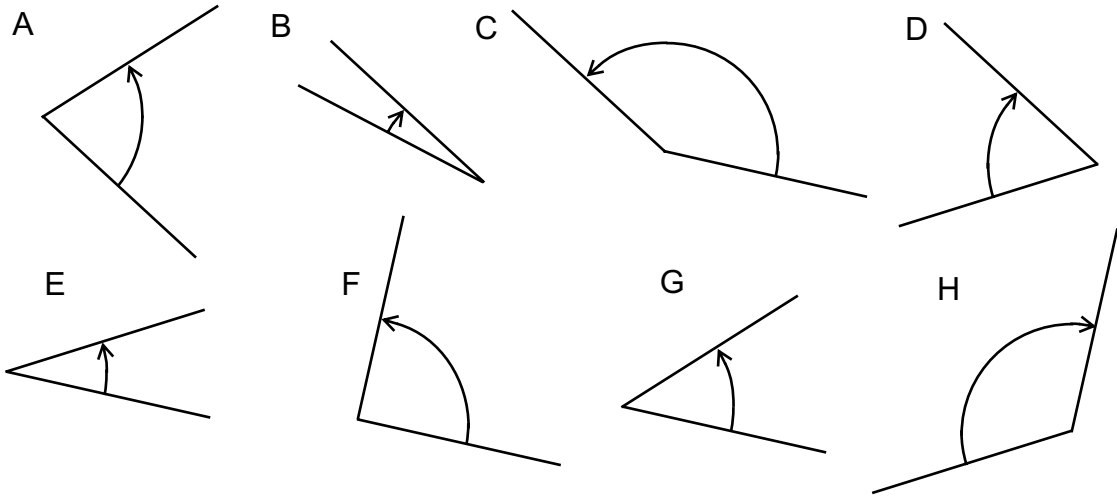

2) Some of these angles are acute, some are obtuse and some are right angles. Say which are which.

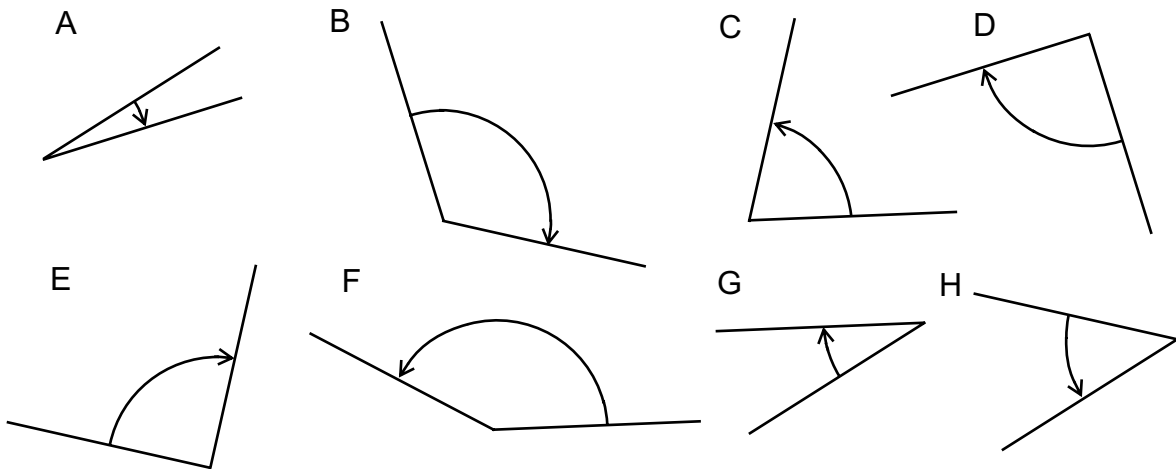

3) In the diagrams below there are 11 angles marked A to K. Write down whether each angle is acute, obtuse or right.

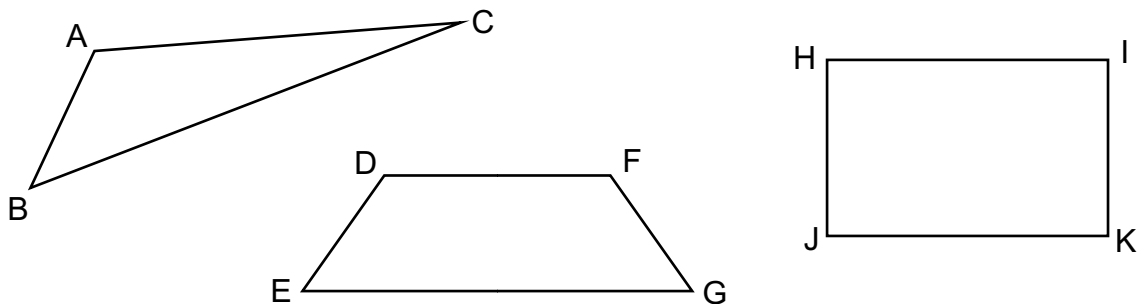

Turning

L.3

1)

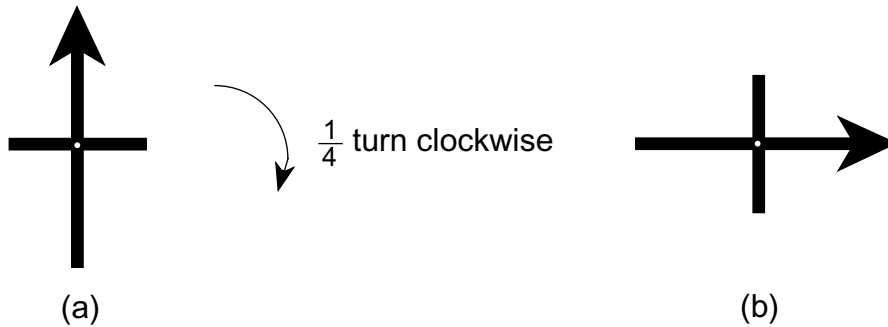

Draw the shape that diagram (a) will look like when it is rotated

- (i) $\frac{1}{4}$ of a turn anticlockwise
- (ii) $\frac{1}{2}$ of a turn anticlockwise
- (iii) $\frac{1}{2}$ of a turn clockwise
- (iv) $\frac{3}{4}$ of a turn clockwise
- (v) $1\frac{1}{4}$ turns anticlockwise

2)

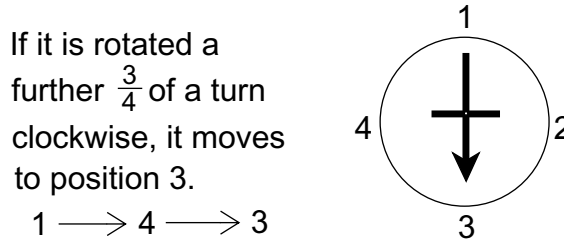
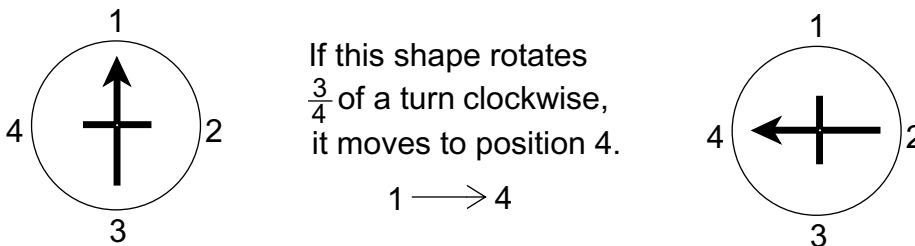

a) Continue this number sequence for $\frac{3}{4}$ of a turn clockwise until you reach position 4 again

b) This number sequence begins at position 2.

$$2 \longrightarrow 1 \longrightarrow 4$$

What kind of turn does it describe?

c) What is the number sequence for $1\frac{1}{4}$ turns clockwise, starting at position 1?

d) What is the number sequence for $1\frac{3}{4}$ turns anticlockwise starting at position 3?

Similar Shapes

L.3

Morag wants to enlarge a shape.

She does this by using 4 shapes of the same size (called congruent shapes).

Her result with the triangle is shown below.

Do this with the other shapes in questions 1 to 5. Use 4 congruent shapes each time.

In question 6 use 12 triangles to get a bigger similar trapezium.

1. Triangle

2. Rectangle

3. Rhombus

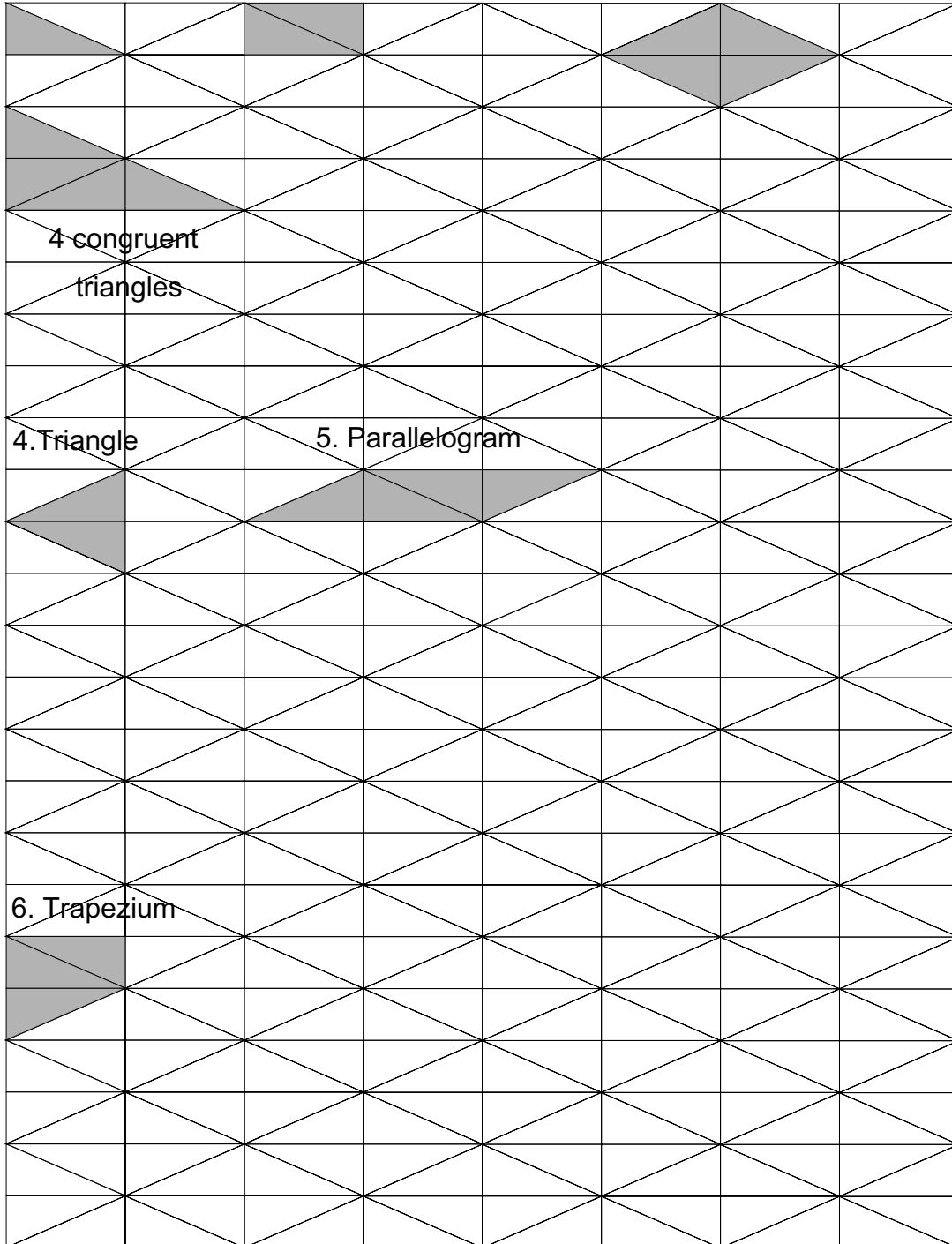

Fitting Shapes

L.3

1) Each of these diagrams have been made up from triangles like this
Draw these shapes and show the triangles in them.

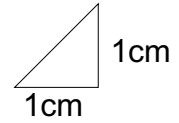

Question a) has been done for you

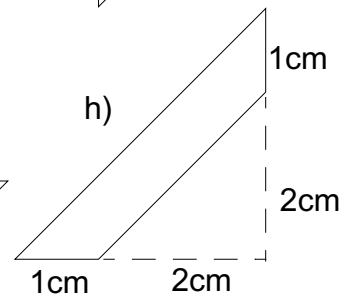
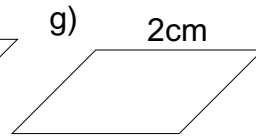
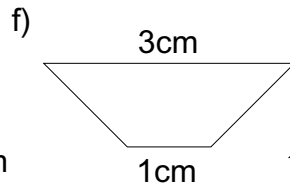
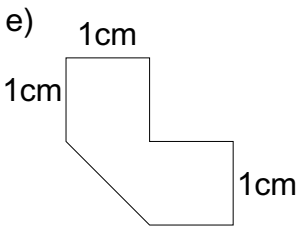
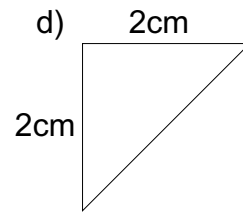
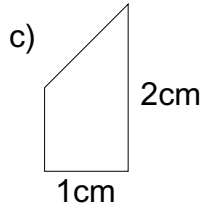
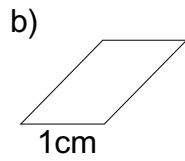
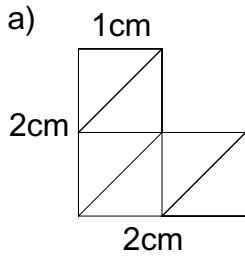

2) How many tiles like this

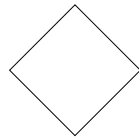

will fit into each of these shapes? Sketch each shape and show the tiles.

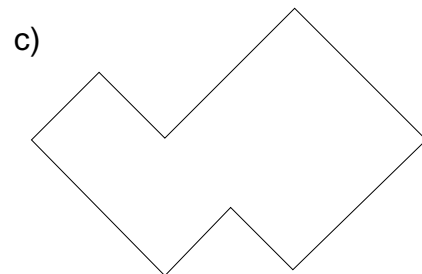
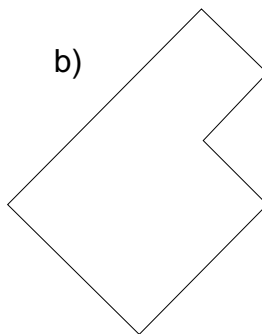
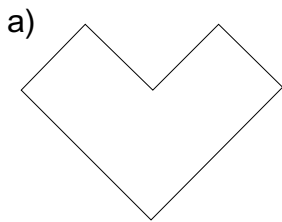

3) How many tiles like this

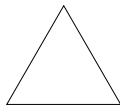

will fit into each of the shapes below? Sketch each shape and show the tiles.

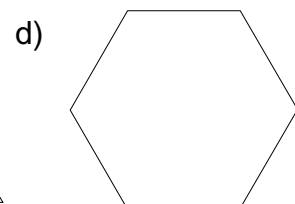
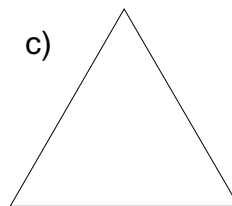
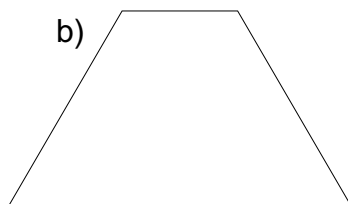
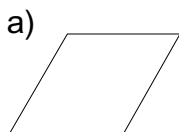

Reflection Symmetry

L.3

Each of these shapes has reflection symmetry.

Copy these shapes.

Draw on them the lines of symmetry.

Some may have only one line of symmetry, some may have more.

a)

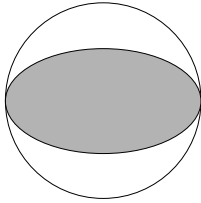

b)

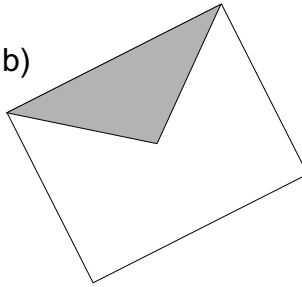

c)

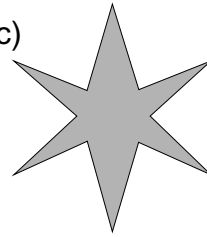

d)

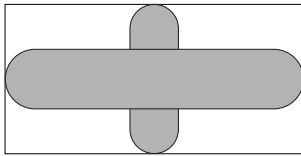

e)

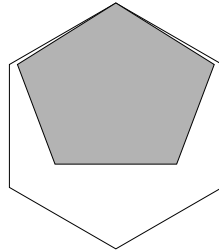

f)

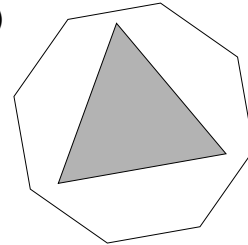

g)

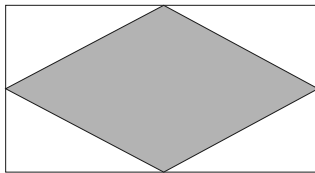

h)

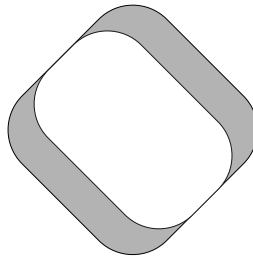

i)

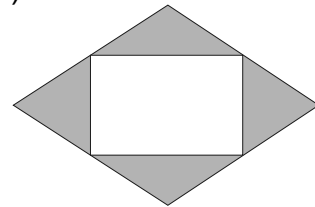

j)

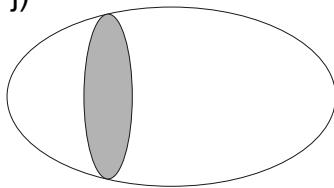

k)

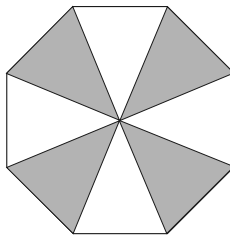

l)

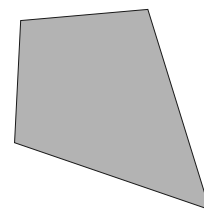

m)

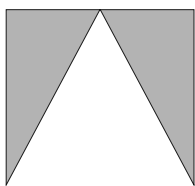

n)

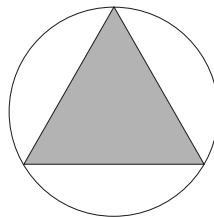

o)

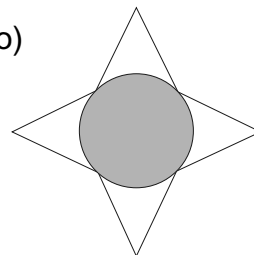

3 Dimensional Shapes

L.3

Here are the names of some 3 dimensional shapes.

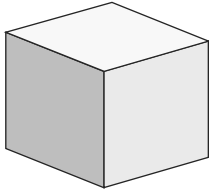

Cube

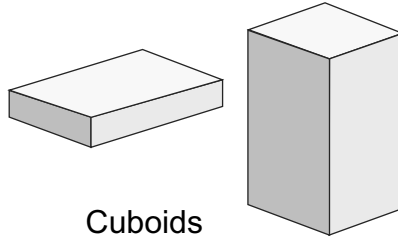

Cuboids

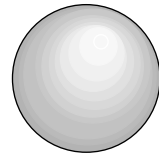

Sphere

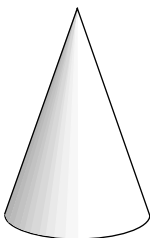

Cone

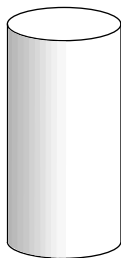

Cylinder

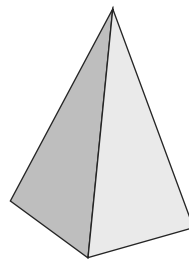

Pyramid

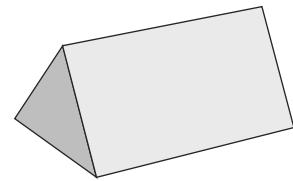

Triangular Prism

1) Which of the shapes above best describe these objects?

- a) A cherry
- b) A tin of baked beans
- c) A box of corn flakes
- d) A marble
- e) A shoe box
- f) A bubble
- g) A wizards hat
- h) A dice
- i) The moon
- j) An oxo
- k) The trunk of a tree
- l) A toilet roll

2) These shapes have been made up of more than one smaller shape. Say what the smaller shapes are.

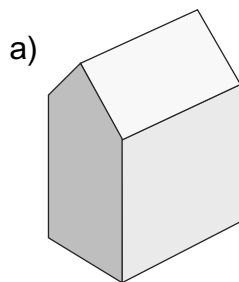

A House

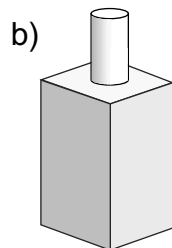

A Chimney



A Crayon

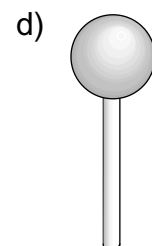

A Lollipop

Measurements

L.3

Exercise 1

In each case, say which of the three alternatives is true.

- 1) The distance from London to Manchester is - a) 320 metres b) 320 centimetres
c) 320 kilometres
- 2) The height of a house is - a) 10 metres b) 10 centimetres c) 10 millimetres
- 3) The weight of a book is - a) 1 gram b) 1 kilogram c) 1 milligram
- 4) A large bottle of cola holds - a) 2 litres b) 2 millilitres c) 20 millilitres
- 5) The weight of a man is - a) 80 grams b) 80 kilograms c) 80 tonnes
- 6) A bag of sugar weighs - a) 1 gram b) 10 grams c) 100 grams d) 1000 grams
- 7) My handspan measures - a) 15mm b) 15cm c) 15m
- 8) The thickness of a book is - a) 3cm b) 30cm c) 300cm
- 9) A cup full of coffee holds - a) 20 millilitres b) 200 millilitres c) 2 litres
- 10) The height of a table is - a) 75mm b) 75cm c) 75m
- 11) The height of a hedge is - a) 150cl b) 150cm c) 150g
- 12) The amount of water in the bath is - a) 200 metres b) 200 grams c) 200 litres

Exercise 2

In each of the following, say which two are equal.

- 1) 100cm, 1 metre, 10mm, 10cm
- 2) 60 litres, 60ml, 600ml, 6000ml, 6 litres
- 3) 7kg, 70g, 70kg, 7000g, 700g
- 4) 1000mm, 1km, 1000cm, 1000m
- 5) 10g, 100g, 1kg, 1000g
- 6) 300mm, 30cm, 3cm, 3m, 30m
- 7) 20 litres, 200ml, 2000ml, 20ml, 2 litres

Exercise 3

In each of the following, write down which measurement you would use.

Each time choose one of the measurements from this list:-

millimetres, centimetre, metre, gram, kilogram, millilitre, litre.

- 1) To measure the length of a garden.
- 2) To measure the weight of an egg.
- 3) To measure the capacity of a car's petrol tank.
- 4) To measure the length of pencil.
- 5) To measure the weight of a man.
- 6) To measure the capacity of a teaspoon.

Reading Scales

L.3

In each of the following diagrams say what number the arrow is pointing to.
In some cases you will have to approximate

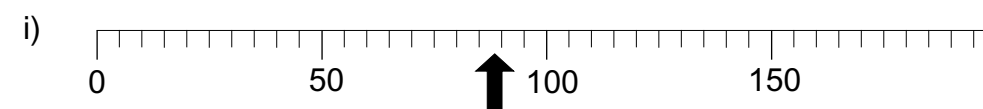
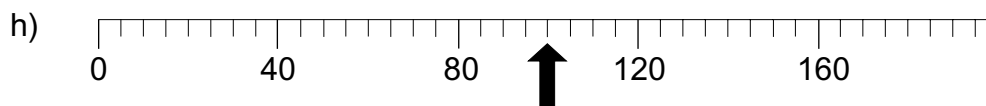
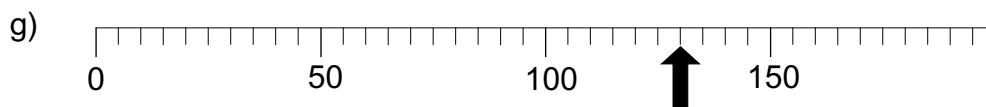
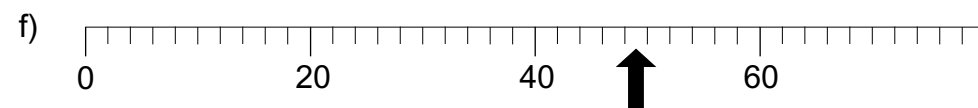
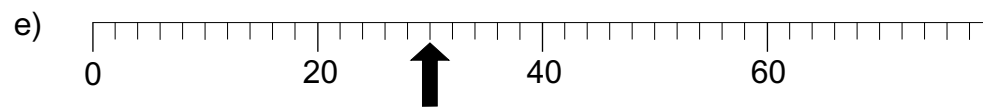
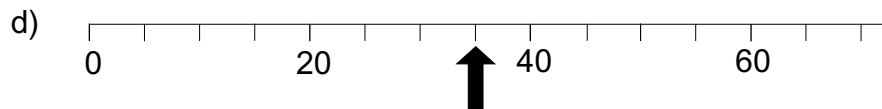
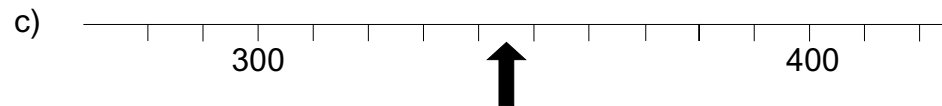
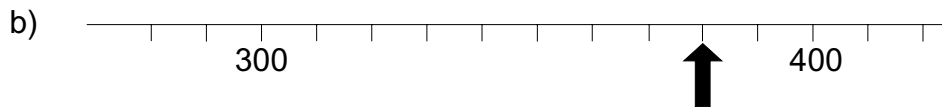
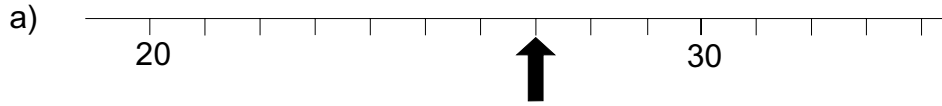

Time Intervals

L.3

What is the time interval between these pairs of clocks?

a)

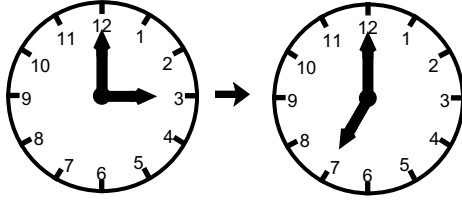

b)

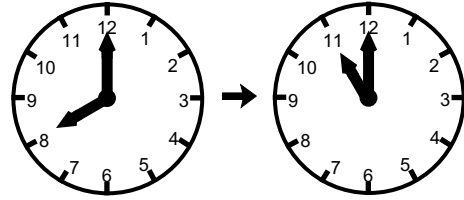

c)

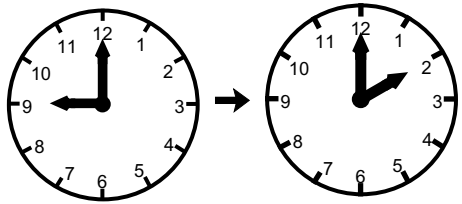

d)

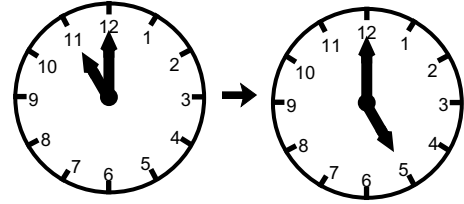

e)

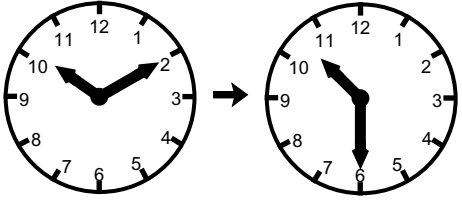

f)

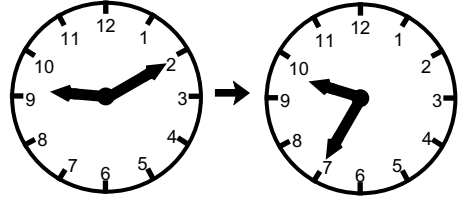

g)

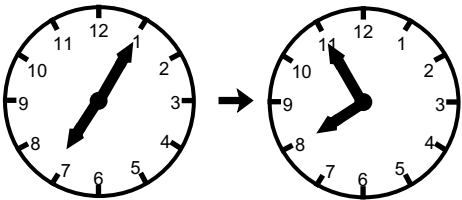

h)

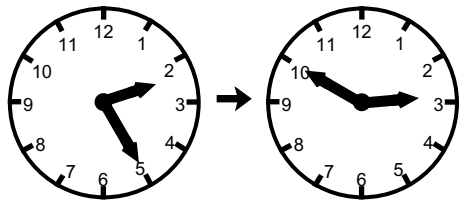

i)

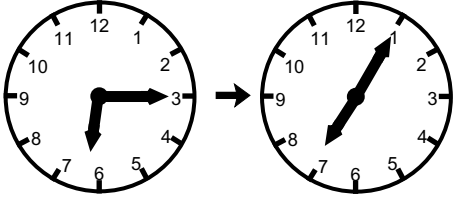

j)

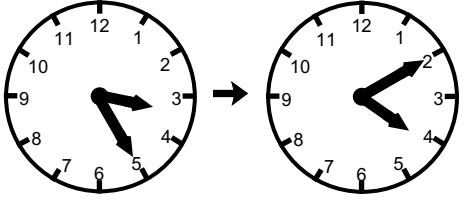

k)

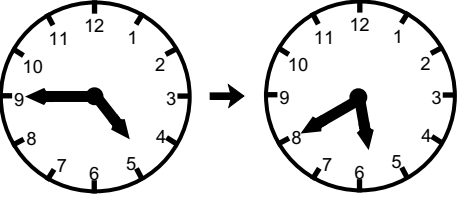

l)

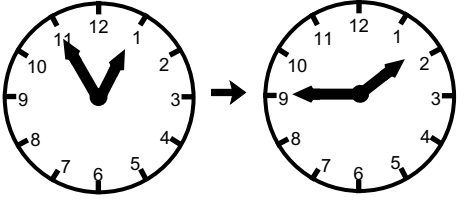

Paving Stones

L.3

A garden centre sells paving stones to make patios. The square paving stones are in three sizes.

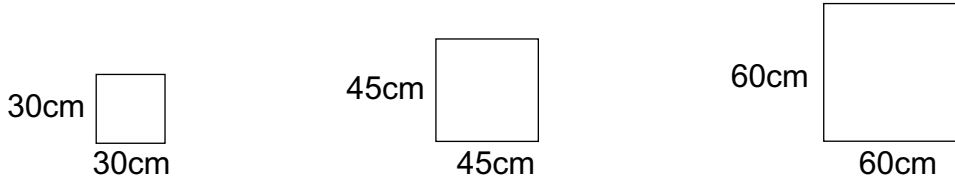

Twelve 30cm paving stones fit like this

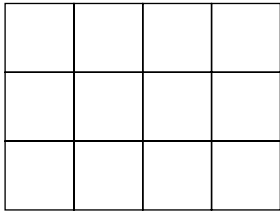

Six 45cm paving stones fit like this

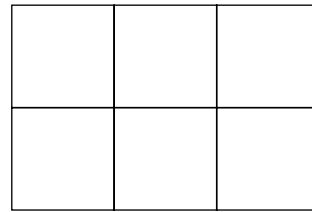

How many paving stones will be needed for these patios?

1) Length 180cm

Width 120cm

Using 30cm paving stones.

2) Length 360cm

Width 180cm

Using 60cm paving stones

3) 300cm

180cm

Using 30cm paving stones

4) 360cm

360cm

Using 60cm paving stones

5) 450cm

180cm

Using 45cm paving stones

Information

L.3

1) Leo does a survey of all the people in his class. This was the result.

	Number of boys	Number of girls
Blond hair	1	2
Brown hair	7	9
Black hair	5	6

Use the table to write down the answers to these questions

- a) How many boys are in Leo's class?
- b) How many girls are in Leo's class?
- c) How many people have blond hair?
- d) How many girls have black hair?

2) The menu for The Bridge Cafe is shown below.

Soup.....	£1.20
Main course	
Fish, chips, peas, bread and butter.....	£3.78
Mixed grill.....	£4.85
Jacket potato with cheese filling.....	£2.55
Roast chicken, potatoes and vegetables.....	£4.28
Roast beef, Yorkshire pudding and vegetables.....	£4.56
Puddings	
Bread and butter pudding.....	£1.80
Ice cream.....	£1.50
Apple pie and custard.....	£1.60
Drinks	
Pot of tea.....	£0.80
Coffee.....	£0.75
Orange juice.....	£0.65

Use the menu to calculate the cost of a meal for each of the people in a, b and c.

- a) Dianne has a jacket potato, ice cream and an orange juice.
- b) Tony has a mixed grill, apple pie and custard with a cup of coffee.
- c) Ben has soup, followed by roast chicken, potatoes and vegetables then bread and butter pudding. He finishes with a pot of tea.
- d) If you have a £10 note what would you buy? Calculate the cost of the food.
What change do you have left?
- e) Jill has £5.50. She wants to buy fish, chips, peas, bread and butter with a pudding.
What is the most expensive pudding she can buy?

Reading Tables

L.3

- 1) The A6 road begins in London and ends in Carlisle.
The table below shows some of the towns it goes through.
The number is the distance of that town from London.

London	0 miles
Luton	32 miles
Leicester	96 miles
Derby	124 miles
Manchester	189 miles
Kendal	255 miles
Carlisle	307 miles

For example - Derby is 124 miles from London.

Use the table to do each of these.

- How far is Manchester from London?
 - How far is Kendal from Manchester?
 - What is the distance from Carlisle to London?
 - Jim travels from Luton to Derby using the A6. How far does he travel?
 - Which is further, Leicester from London or Leicester from Manchester?
- 2) The chart shows the cost of a nights stay at a four different hotels.

Type of Hotel	1st Jan – 31st Mar 1st Nov – 31st Dec		1st Apr – 31st May 1st Sep – 31st Oct		1st Jun – 31st Aug	
	Adult	Child	Adult	Child	Adult	Child
4 star	£60	£33	£70	£39	£81	£42
3 star	£52	£30	£61	£33	£69	£36
2 star	£41	£22	£47	£29	£55	£31
1 star	£36	£19	£40	£22	£48	£29

For example - the cost for a child to stay for 1 night in a 4 star hotel in September is £39. If the child stays 2 nights the cost is $2 \times £39 = £78$.

Use the chart to answer these questions.

- What is the cost of 1 nights stay for an adult at a 2 star hotel in August?
- What is the cost of 1 nights stay for a child at a 2 star hotel in August?
- What is the cost of 7 nights stay for an adult at a 2 star hotel in August?
- What is the cost of 7 nights stay for a child at a 2 star hotel in August?
- What is the cost of 1 weeks stay for a family of 2 adults and 3 children at a 2 star hotel in August?

Information Tables

L.3

1) The table below shows the number of pairs of shoes sold in a shoe shop during one week.

	Monday	Tuesday	Wednesday	Thursday	Friday	Saturday
Women's	10	9	12	7	11	15
Men's	8	5	6	7	8	11
Boy's	3	5	1	5	3	23
Girl's	2	2	4	4	1	19

For example, 10 pairs of women's shoes were sold on Monday.

Use the table to answer these questions.

- How many pairs of boy's shoes were sold on Wednesday?
- How many pairs of shoes were sold on Wednesday?
- How many pairs of men's shoes were sold during the week?
- What was the total number of pairs of shoes sold during the week?
- Why were more children's shoes sold on Saturday?

2) Look at this table. It shows part of the bus timetable from High Street to Earlsway.

Town Buses – High Street to Earlsway					
High Street <i>departs</i>	08:40	09:25	10:40	11:25	12:40
Earlsway <i>arrives</i>	09:05	09:50	11:05	11:50	13:05

For example, the 09:25 bus from the High Street arrives at Earlsway at 09:50.

- A bus leaves High Street at 10:40. At what time does it arrive at Earlsway?
- How long does this bus take to travel from High Street to Earlsway?
- Karen has to get to Earlsway for 11:30. What is the latest bus she can catch from High Street?
- The last bus of the day leaves High Street at 22:10. At what time do you think it will arrive at Earlsway?
- The 11:25 from High Street is delayed by road works. It arrives at Earlsway at 12.03. For how long was it delayed?
- The next day the 09:25 was delayed by 6 minutes. At what time did it arrive at Earlsway?

Calendar

L.3

The calendar for the first six months of a year is shown below.

January					February							
S		6	13	20	27	S		3	10	17	24	
M		7	14	21	28	M		4	11	18	25	
T	1	8	15	22	29	T		5	12	19	26	
W	2	9	16	23	30	W		6	13	20	27	
T	3	10	17	24	31	T		7	14	21	28	
F	4	11	18	25		F	1	8	15	22		
S	5	12	19	26		S	2	9	16	23		
March					April							
S		3	10	17	24	31	S		7	14	21	28
M		4	11	18	25		M	1	8	15	22	29
T		5	12	19	26		T	2	9	16	23	30
W		6	13	20	27		W	3	10	17	24	
T		7	14	21	28		T	4	11	18	25	
F	1	8	15	22	29		F	5	12	19	26	
S	2	9	16	23	30		S	6	13	20	27	
May					June							
S		5	12	19	26	S		2	9	16	23	30
M		6	13	20	27	M		3	10	17	24	
T		7	14	21	28	T		4	11	18	25	
W	1	8	15	22	29	W		5	12	19	26	
T	2	9	16	23	30	T		6	13	20	27	
F	3	10	17	24	31	F		7	14	21	28	
S	4	11	18	25		S	1	8	15	22	29	

Use this calendar to answer these questions

- On what day of the week is May 7th?
- What date comes before May 1st?
- How many days are there in February?
- How many Tuesdays are there in April?
- How many Fridays are there in January?
- What is the 5th day after January 18th?
- What is the date of the 4th Saturday in June?
- What is the 5th day after January 30th?
- How many days are there from April 22nd to May 20th?
- On what day of the week is July 1st?
- On what day of the week was December 31st?
- On what day of the week is July 7th?
- On what day of the week was December 25th?
- How many weeks are there from Sunday February 17th to Saturday June 1st?

Using Information

L.3

1) The table shows the distances between some towns in Great Britain.

	Aberdeen																	
471																		
434	123																	
537	118	108																
126	336	298	401															
361	111	101	204	255														
549	238	120	155	390	216													
237	277	210	320	108	177	288												
489	292	175	268	360	241	115	257											
632	247	203	163	496	299	241	416	354										

Two have been highlighted for you.

The distance between Aberystwyth and Liverpool is 111 miles.

The distance between Edinburgh and Plymouth is 496 miles.

Use the table to answer these questions.

- What is the distance between Plymouth and Newcastle?
- What is the distance between Cardiff and Newcastle?
- Which two towns are furthest apart?
- Which two towns are closest?
- Reg normally travels from Edinburgh to London directly. One day he has to travel to Birmingham first, then on to London. How many extra miles does he travel?
- Which town is furthest from Liverpool?

2) The TV listings for part of an evening are shown below.

- 7:00 Film
- 8:45 Evening News
- 9:05 History Programme
- 9:50 Documentary
- 10:35 Football

Use the table to answer these questions.

- For how long did the film last?
- For how long did the documentary last?
- If the football programme lasted for 45 minutes, at what time did it finish?
- The programme before the film lasted for half an hour. At what time did it start?

Pictograms

L.3

- 1) The pictogram shows the number of fruit pies sold by a baker.
Each square represents 10 pies

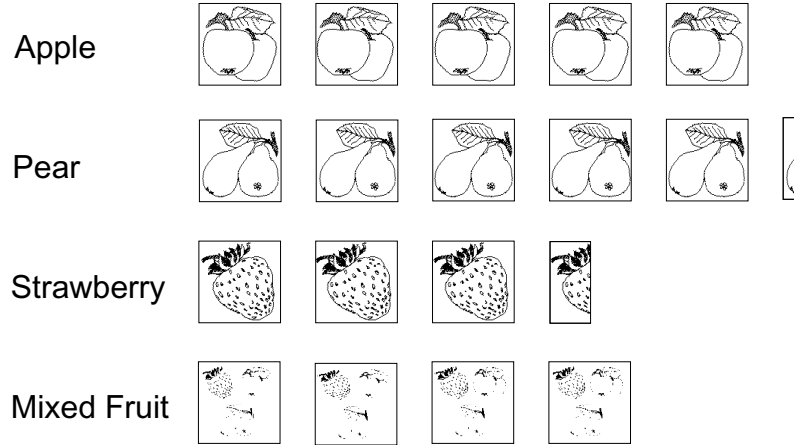

Look at the diagram and answer these questions.

- How many apple pies were sold?
 - How many strawberry pies were sold?
 - Approximately how many pear pies were sold?
 - The number of mixed fruit pies sold was 47. Draw the shape missing from the diagram.
- 2) A class of pupils were asked what types of pet they had. The results are shown on the pictogram below. One square represents 4 replies.

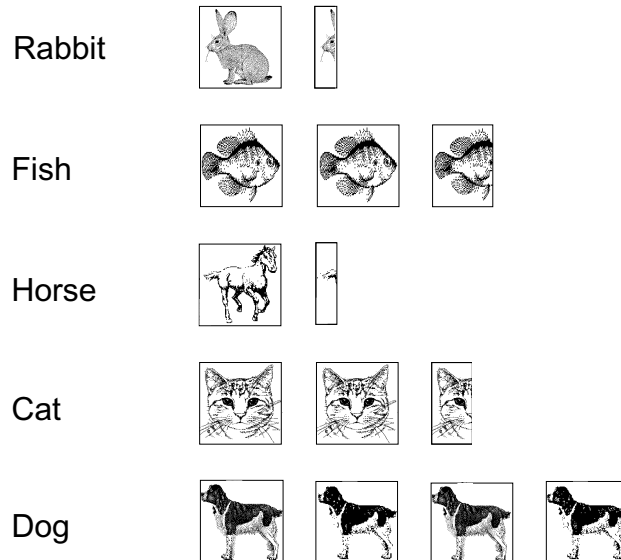

- How many pupils said that they have a dog?
- How many pupils said they kept fish?
- How many pupils said that they kept a cat?
- Which two groups had the same number of replies?
- What was the total number of replies?

Bar Charts

L.3

1) Peter does a survey. He asks the pupils in his group how they get to school. He puts the data onto a block diagram, like this.



- How many pupils go to school by bus?
- What was the most popular way of getting to school?
- What way of getting to school did 4 people have?
- How many pupils did Peter ask?

2) The bar chart shows the items sold during one month in an electrical shop.

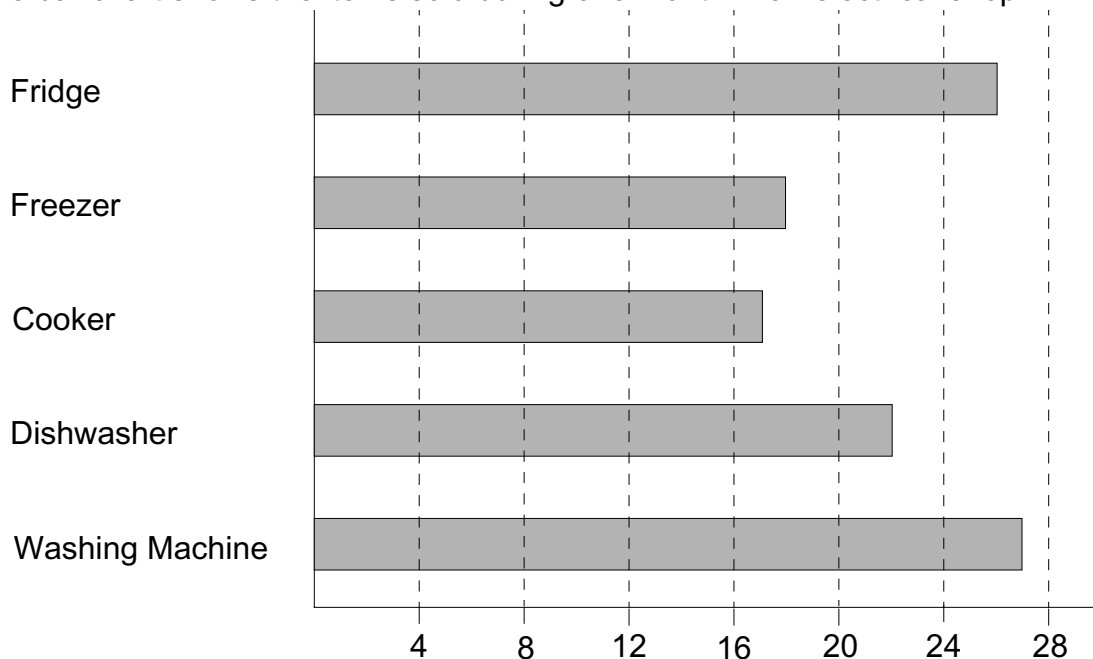

Use the diagram to answer the questions.

- What was the most popular item sold?
- How many cookers were sold?
- How many fridges were sold?
- What was the total number of items sold?

Charts and Pictograms



L.3

- 1) Kim does a survey. She asks the pupils in her class what their favourite pet is. She puts the data down like this.





Type of pet	Number of people
Dog	5
Cat	10
Hamster	8
Fish	4
Other	7

- What animal was the most popular?
 - What does 'other' mean? Give an example.
 - Draw a bar chart to show this data. Draw the bars horizontally.
- 2) The table below shows the number of people who bought drinks in a cafe during one day. Draw a pictogram to show the data.

Type of drink	Number of people
Cola	13
Tea	15
Coffee	10
Squash	12
Milk	7

Use a figure like this  to represent two people and half  to represent one.

- 3) Jill surveys the first 50 sales at the lunchtime tuck shop. Here are her results.

Type of snack	Number of sales
Apple	
Chocolate bar	
Orange	
Crisps	
Biscuits	

- How many chocolate bars were sold?
- Use this data to draw a pictogram. Use one square to represent 4 sales. Put your own picture in the squares. The first line has been done for you.

Apple   

Frequency Tables

L.3

- 1) Rifat does a survey. She asks the pupils in her class what kind of pet they have. She records the data in a frequency table like this.

Pet	Tally	Frequency
Dog		9
Cat		11
Hamster		3
Fish		5
Other		10
	Total	38

Look at the table then answer the questions.

- a) Rifat has made a mistake. She has added up one set of tally marks wrong. Which is it?
- b) What should the total be?
- c) Which animal is there most of?
- d) There are 29 pupils in the class. Why is the total more than 29?
- 2) Daniel does a survey. He asks pupils in his class how they get to school. He recorded the data on a frequency table.

Transport	Tally	Frequency
Taxi		
Walk		
Bus		
Bicycle		
Car		
	Total	

- a) Copy the table into your book. Write down all the numbers in the frequency column
- b) How many pupils did Daniel ask?
- c) What was the most popular way of getting to school?
- d) What was the least popular way of getting to school?

Putting Data into Tables

L.3

1) Andrew does a survey.

He asks the pupils in his class which breakfast they like best.

He gives them the choice of Cold Cereal (C), Porridge (P), Egg and Bacon (E), Toast (T), None of these (N).

This is his list of results.

C, C, E, P, N, E, C, E, C, C, C, E, P, T, T, N, C, C, T, P, E, E, C, T, C, P, E, C, N, T

a) Copy this frequency table into your book and complete it. Fill the tally in first, then the frequency.

Breakfast	Tally	Frequency
Cold Cereal		
Porridge		
Egg and Bacon		
Toast		
None of these		
	Total	

Use the table to answer these questions.

- How many pupils like Egg and Bacon best?
- How many pupils are there in the class?
- What is the favourite breakfast?

2) The ages of the children who go to judo club are

11, 12, 11, 13, 12, 11, 14, 11, 12, 12, 14, 13, 12, 12, 12, 11, 13, 14, 13, 12

a) Copy this frequency table into your book and complete it.

Age	Tally	Frequency
11		
12		
13		
14		
	Total	

- How many members are aged 11?
- How many members are there altogether?

Adding Decimals

Do not use a calculator

L.4

1) Add together the numbers in each of the following

a)

$$\begin{array}{r} 11.0 \\ + 3.6 \\ \hline \end{array}$$

b)

$$\begin{array}{r} 24.00 \\ + 358.98 \\ \hline \end{array}$$

c)

$$\begin{array}{r} 0.6 \\ + 3.87 \\ \hline \end{array}$$

d)

$$\begin{array}{r} 12.8 \\ + 27 \\ \hline \end{array}$$

e)

$$\begin{array}{r} 64.8 \\ 9.87 \\ + 285 \\ \hline \end{array}$$

f)

$$\begin{array}{r} 5.98 \\ 14.6 \\ + 38 \\ \hline \end{array}$$

g)

$$\begin{array}{r} 5.87 \\ 5 \\ + 17 \\ \hline \end{array}$$

h)

$$\begin{array}{r} 8.7 \\ 0.76 \\ + 3.6 \\ \hline \end{array}$$

i)

$$\begin{array}{r} 75 \\ 86.4 \\ + 100 \\ \hline \end{array}$$

j)

$$\begin{array}{r} 2.87 \\ 0.87 \\ + 0.4 \\ \hline \end{array}$$

k)

$$\begin{array}{r} 65.9 \\ 6 \\ + 4.87 \\ \hline \end{array}$$

l)

$$\begin{array}{r} 2.87 \\ 532.76 \\ + 438 \\ \hline \end{array}$$

m) $3 + 15 + 5.9$

n) $23 + 240 + 34.7$

o) $38 + 9.4 + 3$

p) $45 + 9.0 + 5.3$

q) $45 + 7.56 + 19.04$

r) $76 + 398 + 56.91$

s) $654 + 34.94 + 45.9$

t) $96 + 76.94 + 72.9$

u) $63.0 + 56 + 453.97$

2) Dawn buys a radio for £12.75, a compact disc for £9.99 and a pack of batteries for £2.59. How much does she spend altogether?

3) Kate buys a bicycle for £99.99, a cycle helmet for £16.56 and some reflecting strips for £5.34. How much does she spend altogether?

4) David's dad buys a bottle of fizzy water for £1.05, a large bag of potatoes for £3.56 and some tins of cat food for £4.08. How much does he spend altogether?

5) Mrs. Davies pays her electricity bill every 3 months.

In January she pays £123.67.

In April she pays £164.59.

In July she pays £97.

In October she pays £117.74.

How much does she pay for the whole year?

6) Dylan goes with his mum to the Garden Centre. They buy a plant for £5.78, some pots for £2.97 and a bag of compost for £4.76. What is their total bill?

7) The three sides of a triangle measure 15.6 centimetres, 12.7 centimetres and 14 centimetres. What is the perimeter of the triangle?

8) The four sides of a quadrilateral measure 23cm, 18.5cm, 15.74cm and 9.7cm. Calculate its perimeter.

9) A lift contains 4 people. They weigh 72.5kg, 65.63kg, 89.52kg and 90kg. What is the total weight of the people in the lift?

Subtracting Decimals

Do not use a calculator

L.4

1) Subtract the following.

$$\begin{array}{r} \text{a)} \\ 345.9 \\ - 16.4 \\ \hline \end{array}$$

$$\begin{array}{r} \text{b)} \\ 234.98 \\ - 21.57 \\ \hline \end{array}$$

$$\begin{array}{r} \text{c)} \\ 366.7 \\ - 46.5 \\ \hline \end{array}$$

$$\begin{array}{r} \text{d)} \\ 585.74 \\ - 346.33 \\ \hline \end{array}$$

$$\begin{array}{r} \text{e)} \\ 648.6 \\ - 126.7 \\ \hline \end{array}$$

$$\begin{array}{r} \text{f)} \\ 438.85 \\ - 137.9 \\ \hline \end{array}$$

$$\begin{array}{r} \text{g)} \\ 374.06 \\ - 231.3 \\ \hline \end{array}$$

$$\begin{array}{r} \text{h)} \\ 173.64 \\ - 42.48 \\ \hline \end{array}$$

$$\begin{array}{r} \text{i)} \\ 384.65 \\ - 265.07 \\ \hline \end{array}$$

$$\begin{array}{r} \text{j)} \\ 594.3 \\ - 28.73 \\ \hline \end{array}$$

$$\begin{array}{r} \text{k)} \\ 164.84 \\ - 136.69 \\ \hline \end{array}$$

$$\begin{array}{r} \text{l)} \\ 643.8 \\ - 364.77 \\ \hline \end{array}$$

m) $263.85 - 45.8$

n) $648.64 - 54.5$

o) $74.70 - 6.45$

p) $567 - 43.8$

q) $453.7 - 67.87$

r) $85.64 - 7.9$

- 2) Sean buys a bottle of cola for £1.06. What change does he get if he pays for it with a £10 note?
- 3) A piece of wood measures 240 centimetres. Nazir cuts 165.8 centimetres from it. What length is left over?
- 4) Paula's dad weighs 92.4 kilograms. He goes on a diet and loses 9.7kg. What is his new weight?
- 5) Michael buys a jacket with a £50 note. If the jacket costs £33.79, what change will he get?
- 6) Jack comes first in a race. His time was 45.65 seconds. James comes last in the same race. His time was 50.34 seconds. How much faster was Jack than James?
- 7) Glyn's height is 1.54 metres. Sarah's height is 1.38 metres. By how much is Glyn taller than Sarah?
- 8) A lift has a maximum capacity of 295kg. Four people enter the lift. If their total weight is 317.65kg, by how much are they over the limit?
- 9) The perimeter of a triangle is 56.83cm. Two of the sides measure 19.03cm and 22.5cm. What is the length of the third side?
- 10) Jenny has £348.84 in her bank account. She takes out £194.65. What does she have left?
- 11) Jenny takes out some more money. She now has £46.86 in her account. How much did she take out?

Multiplying

Do not use a calculator

L.4

1) Multiply each of the following

$$\begin{array}{r} \text{a)} \\ \times 11 \\ \times 2 \\ \hline \end{array}$$

$$\begin{array}{r} \text{b)} \\ \times 13 \\ \times 3 \\ \hline \end{array}$$

$$\begin{array}{r} \text{c)} \\ \times 21 \\ \times 4 \\ \hline \end{array}$$

$$\begin{array}{r} \text{d)} \\ \times 27 \\ \times 5 \\ \hline \end{array}$$

$$\begin{array}{r} \text{e)} \\ \times 31 \\ \times 6 \\ \hline \end{array}$$

$$\begin{array}{r} \text{f)} \\ \times 42 \\ \times 7 \\ \hline \end{array}$$

$$\begin{array}{r} \text{g)} \\ \times 12 \\ \times 8 \\ \hline \end{array}$$

$$\begin{array}{r} \text{h)} \\ \times 15 \\ \times 9 \\ \hline \end{array}$$

$$\begin{array}{r} \text{i)} \\ \times 30 \\ \times 5 \\ \hline \end{array}$$

$$\begin{array}{r} \text{j)} \\ \times 43 \\ \times 7 \\ \hline \end{array}$$

$$\begin{array}{r} \text{k)} \\ \times 54 \\ \times 2 \\ \hline \end{array}$$

$$\begin{array}{r} \text{l)} \\ \times 62 \\ \times 6 \\ \hline \end{array}$$

$$\begin{array}{r} \text{m)} \\ \times 55 \\ \times 7 \\ \hline \end{array}$$

$$\begin{array}{r} \text{n)} \\ \times 95 \\ \times 2 \\ \hline \end{array}$$

$$\begin{array}{r} \text{o)} \\ \times 54 \\ \times 5 \\ \hline \end{array}$$

$$\begin{array}{r} \text{p)} \\ \times 121 \\ \times 2 \\ \hline \end{array}$$

$$\begin{array}{r} \text{q)} \\ \times 230 \\ \times 4 \\ \hline \end{array}$$

$$\begin{array}{r} \text{r)} \\ \times 142 \\ \times 5 \\ \hline \end{array}$$

$$\begin{array}{r} \text{s)} \\ \times 253 \\ \times 7 \\ \hline \end{array}$$

$$\begin{array}{r} \text{t)} \\ \times 403 \\ \times 6 \\ \hline \end{array}$$

u) 151×2 v) 231×4 w) 183×7 x) 502×4 y) 603×6 z) 501×9

- 2) John's bus journey to and from school each day totals 6 miles. He went to school for 20 days in March. How many miles did he travel in that month?
- 3) A chocolate box contains 23 chocolates. Jane buys 6 boxes for a childrens party. How many chocolates has she bought?
- 4) A lorry will hold 5 tonnes of sand. If it carries 16 loads to a building site, what is the total weight transported?
- 5) There are 52 cards in a pack. Jenny has 4 packs of cards. How many cards does she have altogether?
- 6) Bobbi buys 9 boxes of eggs for her cafe. Each box contains 12 eggs. How many eggs does she buy altogether?
- 7) Sarah plants lettuces in rows of 23 plants. If she has 9 rows how many plants is this?
- 8) Pencils are sold in packs of 6. The mathematics department buys 26 packs. How many pencils do they have?
- 9) A rack holds 16 CD's. Jake has 6 racks. How many CD's does he have when they are all full?
- 10) There are 743 pupils in a school. They all go on a sponsored walk in aid of a charity. If they each get a pledge for £8, how much money will be collected?

Dividing

Do not use a calculator

L.4

1) Divide each of the following.

- | | | | | |
|----------------|----------------|-----------------|-----------------|-----------------|
| a) $50 \div 5$ | b) $22 \div 2$ | c) $36 \div 3$ | d) $48 \div 4$ | e) $65 \div 5$ |
| f) $48 \div 3$ | g) $88 \div 4$ | h) $95 \div 5$ | i) $74 \div 2$ | j) $87 \div 3$ |
| k) $68 \div 4$ | l) $72 \div 6$ | m) $104 \div 4$ | n) $110 \div 5$ | o) $88 \div 8$ |
| p) $84 \div 7$ | q) $96 \div 6$ | r) $108 \div 9$ | s) $108 \div 6$ | t) $136 \div 8$ |

2) Divide each of the following. In each case there will be a remainder.

- | | | | | |
|-----------------|-----------------|-----------------|-----------------|-----------------|
| a) $31 \div 2$ | b) $34 \div 3$ | c) $54 \div 4$ | d) $93 \div 5$ | e) $91 \div 6$ |
| f) $84 \div 5$ | g) $100 \div 8$ | h) $99 \div 7$ | i) $120 \div 9$ | j) $124 \div 3$ |
| k) $173 \div 8$ | l) $185 \div 6$ | m) $187 \div 7$ | n) $223 \div 8$ | o) $148 \div 7$ |

3) Divide each of the following. Some will have remainders.

- | | | | | |
|-----------------|-----------------|-----------------|-----------------|-----------------|
| a) $124 \div 2$ | b) $180 \div 3$ | c) $155 \div 5$ | d) $295 \div 8$ | e) $332 \div 9$ |
| f) $844 \div 2$ | g) $353 \div 4$ | h) $402 \div 6$ | i) $235 \div 7$ | j) $364 \div 5$ |
| k) $493 \div 8$ | l) $537 \div 3$ | m) $543 \div 7$ | n) $654 \div 6$ | o) $781 \div 7$ |

4) A goods train consists of an engine and a number of trucks. Each truck is 8 metres long. The total length of the trucks is 288 metres. How many trucks does the engine pull?

5) Colin places wooden blocks on top of each other for his younger sister. The thickness of each block is 6cm. How many blocks will he have built up when he has a tower 108cm high?

6) Clare has 139 plants to transfer into trays. Each tray will hold 6 plants.

- How many trays does she fill and how many plants are left over?
- How many more plants will she need to fill one more tray?

7) Socks are put into packs of 6 pairs. Simon can pack 1272 pairs of socks in 1 hour. How many packs is this?

8) A village hall will hold 117 people when it is full. If there are 9 rows of seats, how many seats are there in each row?

9) Liam wants to save £190 in order to buy a TV. If he puts £5 each week into his bank, how many weeks will it take to save up the money?

10) A car park can hold 105 cars. There are 7 rows, each holding the same number of vehicles. How many can fit into each row?

11) A driver loads her van with packages. Each package weighs 7kg. The maximum weight her van will hold is 1050kg. What is the most number of packages she can load?

12) Dianne has £2 (or 200p) to spend on chocolate eggs. Each egg costs 6p. What is the most number of eggs she can buy. How much will she have left over?

Writing Fractions

L.4

1) Say what fraction of the dots are black in each case.

a)	b)	c)	d)
e)	f)	g)	h)

2) On the diagram below, point X is approximately half way along the line.

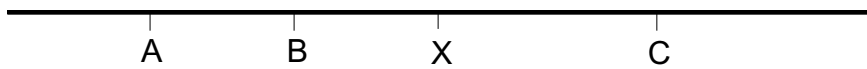

Approximately how far along the line are the points A, B and C?

3) Draw a line of approximately the same length as this one.



- a) Mark on the line point A about $\frac{2}{5}$ of the way along it.
- b) Mark on the line point B about $\frac{7}{10}$ of the way along it.

4) Which of the following are correct and which are incorrect?

- a) Bill got 49 out of 100 in his test. He said that he got about half of his test right.
- b) Nicola got 65 out of 100 in her test. She said that she got about one third of the questions right.
- c) Tracey got 72 out of 100. She said that she got about three quarters of them right.
- d) Dick got 35 out of 100. He said that he got about two thirds right.

5) I set out from my home to London, a distance of 210 miles.

- a) After 54 miles, approximately what fraction of the journey is left?
- b) After 142 miles, approximately what fraction of the journey is left?
- c) After 191 miles, approximately what fraction of the journey is left?

6) Approximately what fraction of these diagrams have been shaded in?

a)	b)	c)	d)	e)
f)	g)	h)	i)	j)

Percentages

L.4

1) Approximately what percentage of the way along the line are the marked points?

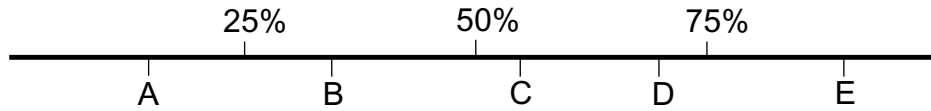

2) Each of these rectangles has been cut into 4 equal parts. Use this to help you to estimate the percentage of the shape shaded in.

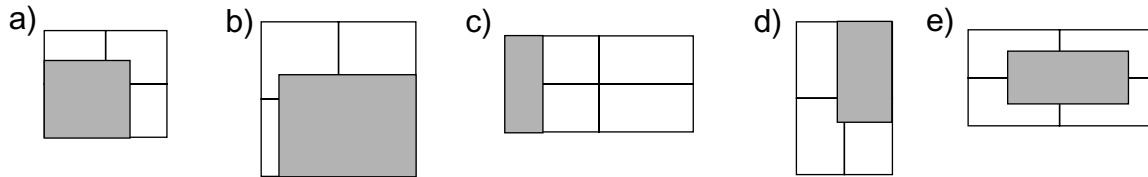

3) Approximately what percentage of these shapes is shaded?

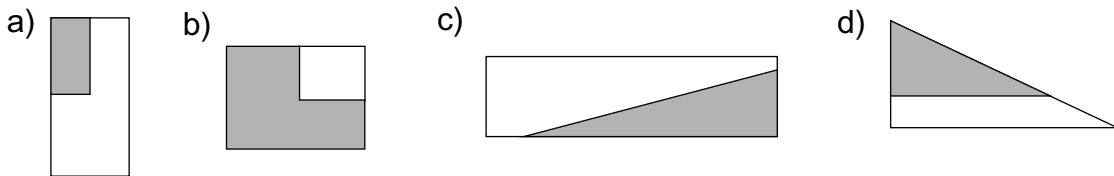

4) There are 910 pupils in a school. 420 pupils are girls. What is the approximate percentage of girls in the school?

5) A length of rope is cut into two parts.

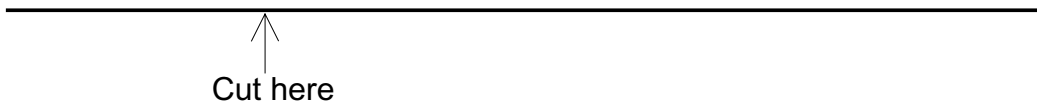

- a) Approximately what percentage of the rope is the shorter part?
- b) Approximately what percentage of the rope is the longer part?

6) The diagram shows a sketch of a house and garden. The lawn has been shaded in.

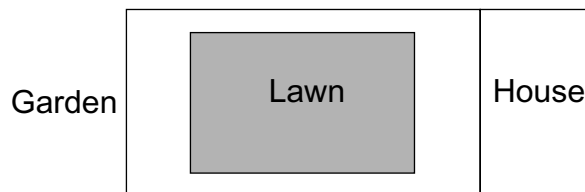

Approximately what percentage of the garden is the lawn?

7) Approximately what percentage of these squares have been shaded in?

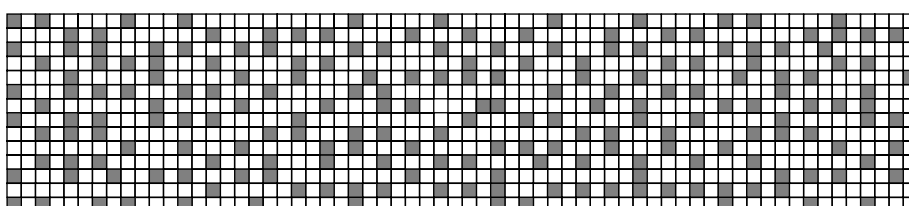

Mixing

L.4

- 1) These are the ingredients to make 16 cakes.
 - 250 grams of butter
 - 250 grams of sugar
 - 400 grams of flour
 - 2 eggs
 - 300 millilitres of milk
 - a) Write out the ingredients for making 8 cakes.
 - b) What ingredients are needed to make 32 cakes?
 - c) Use the answer to part 'a' to calculate the ingredients needed to make 24 cakes.

- 2) These are the ingredients needed for making 12 cheese scones.
 - 60g butter
 - 250g flour
 - 120g grated cheese
 - 1 egg
 - 150ml milk
 - a) What ingredients are needed to make 6 scones?
 - b) What ingredients are needed to make 18 scones?
 - c) What ingredients are needed to make 30 scones?

- 3) Red and yellow paint is mixed to make orange.
 - Bryn mixes 3 tins of yellow with 3 tins of red.
 - Sara mixes 4 tins of yellow with 2 tins of red.
 - Tandi mixes 2 tins of yellow with 4 tins of red.
 - a) Whose mixture gives the reddest shade?
 - b) Whose mixture gives the yellowest shade?
 - c) Sara and Tandi put their mixtures together.
 - Bryn says to Sara 'My mixture is redder than yours'. Is he correct?

- 4) The instruction on a squash bottle says 'Dilute 1 part of squash to 4 parts of water'
 - a) Maria says "I like mine strong so I will mix 1 part of squash with 3 parts of water".
 - Ben says "I like mine strong so I will mix 1 part of squash with 5 parts of water".
 - Who is right? Can you say why?
 - b) If they drink it stronger than the instructions say, will the bottle empty faster or slower?
 - c) Garth makes it according to the instructions. If he uses 40ml of squash, how much water does he use?

Multiplication Tables.

Do not use a calculator

L.4

These are the 39 and 43 times tables.
Complete these tables.

$1 \times 39 = 39$	$1 \times 43 = 43$
$2 \times 39 = 78$	$2 \times 43 = 86$
$3 \times 39 = 117$	$3 \times 43 = 129$
$4 \times 39 = 156$	$4 \times 43 = 172$
$5 \times 39 = 195$	$5 \times 43 = 215$
$6 \times 39 = \dots\dots$	$6 \times 43 = \dots\dots$
$7 \times 39 = \dots\dots$	$7 \times 43 = \dots\dots$
$8 \times 39 = \dots\dots$	$8 \times 43 = \dots\dots$
$9 \times 39 = \dots\dots$	$9 \times 43 = \dots\dots$
$10 \times 39 = \dots\dots$	$10 \times 43 = \dots\dots$

Use them to do these calculations.

- a) $3 \times 39 = \dots\dots$
- b) $4 \times 43 = \dots\dots$
- c) $39 \times 5 = \dots\dots$
- d) $43 \times 5 = \dots\dots$
- e) $312 \div 39 = \dots\dots$
- f) $387 \div 43 = \dots\dots$
- g) $351 \div 9 = \dots\dots$
- h) $195 \div 5 = \dots\dots$
- i) $258 \div 6 = \dots\dots$
- j) $344 \div 8 = \dots\dots$
- k) $10 \times 39 = \dots\dots$
- l) $10 \times 43 = \dots\dots$
- m) $20 \times 39 = \dots\dots$
- n) $30 \times 43 = \dots\dots$
- o) $17 \times 39 = \dots\dots$
- p) $16 \times 43 = \dots\dots$

Combining Multiplication Tables

Do not use a calculator

L.4

1) a) Here are the 8, 9 and 17 times tables. Complete them.

You can calculate the 17 times table by adding together the 9 and 8 times tables.

$1 \times 9 = 9$	$1 \times 8 = 8$	$1 \times 17 = 17$
$2 \times 9 = 18$	$2 \times 8 = 16$	$2 \times 17 = 34$
$3 \times 9 = 27$	$3 \times 8 = 24$	$3 \times 17 = 51$
$4 \times 9 = 36$	$4 \times 8 = 32$	$4 \times 17 = 68$
$5 \times 9 = 45$	$5 \times 8 = 40$	$5 \times 17 = \dots$
$6 \times 9 = \dots$	$6 \times 8 = \dots$	$6 \times 17 = \dots$
$7 \times 9 = \dots$	$7 \times 8 = \dots$	$7 \times 17 = \dots$
$8 \times 9 = \dots$	$8 \times 8 = \dots$	$8 \times 17 = \dots$
$9 \times 9 = \dots$	$9 \times 8 = \dots$	$9 \times 17 = \dots$
$10 \times 9 = \dots$	$10 \times 8 = \dots$	$10 \times 17 = \dots$

b) Use the tables to complete these

$$\begin{aligned} 8 \times 17 &= \dots \\ 8 \times 16 &= \dots \\ 8 \times 18 &= \dots \end{aligned}$$

2) You can calculate the 28 times tables by multiplying the 7 times table by 4

$1 \times 7 = 7$		$1 \times 28 = 28$
$2 \times 7 = 14$		$2 \times 28 = 56$
$3 \times 7 = 21$		$3 \times 28 = 84$
$4 \times 7 = 28$		$4 \times 28 = 112$
$5 \times 7 = 35$	$\times 4 =$	$5 \times 28 = 140$
$6 \times 7 = \dots$		$6 \times 28 = \dots$
$7 \times 7 = \dots$		$7 \times 28 = \dots$
$8 \times 7 = \dots$		$8 \times 28 = \dots$
$9 \times 7 = \dots$		$9 \times 28 = \dots$
$10 \times 7 = \dots$		$10 \times 28 = \dots$

a) Complete the 7 times table and the 28 times table.

b) Use the table to complete these.

$$\begin{aligned} 8 \times 28 &= \dots \\ 8 \times 35 &= \dots \\ 8 \times 42 &= \dots \end{aligned}$$

Missing Numbers

Do not use a calculator

L.4

1) If $27 - 5 = 22$, fill in the missing numbers in each of the following.

a) $22 + \dots = 27$

b) $27 - \dots = 5$

c) $5 + \dots = 27$

2) If $23 \times 15 = 345$, fill in the missing numbers in each of the following.

a) $15 \times \dots = 345$

b) $345 \div \dots = 15$

c) $345 \div \dots = 23$

3) If $34 + 45 = 79$

Then: a) $79 - \dots = 45$

b) $79 - \dots = 34$

c) $45 + \dots = 79$

4) If $16 \times 10 = 160$

Then: a) $10 \times \dots = 160$

b) $160 \div \dots = 10$

c) $\dots \div 10 = 16$

5) If $420 \div 35 = 12$

Then: a) $420 \div \dots = 35$

b) $\dots \times 35 = 420$

c) $\dots \times 12 = 420$

6) Fill in the missing numbers in the following. All the answers are 8.

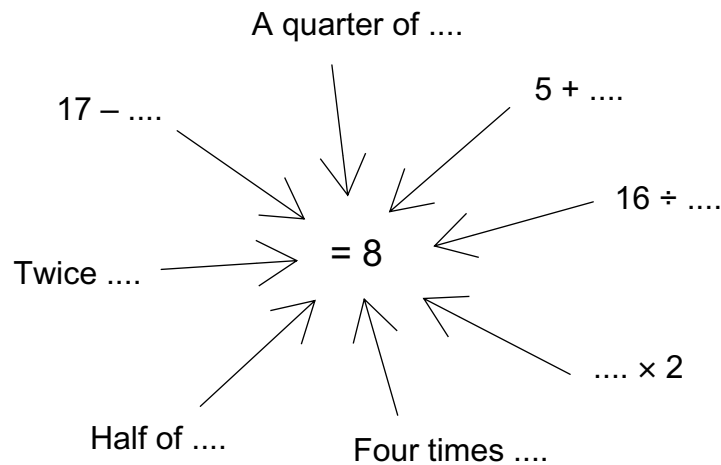

7) Fill in the missing sign, \times , \div , $+$ or $-$

a) $12 \dots 2 = 6$

b) $12 \dots 3 = 15$

c) $4 \dots 3 = 12$

d) $15 \dots 5 = 3$

e) $50 \dots 10 = 5$

f) $4 \dots 10 = 40$

g) $19 \dots 9 = 10$

h) $14 \dots 9 = 23$

i) $14 \dots 7 = 21$

j) $30 \dots 3 = 10$

k) $5 \dots 6 = 30$

l) $30 \dots 20 = 10$

8) Fill in the missing numbers, so that both sides of the $=$ sign are equal.

For example: $24 \div 4 = 12 \div 2$

a) $27 + 3 = 17 + \dots$

b) $42 - 15 = 32 - \dots$

c) $30 \times 10 = 3 \times \dots$

d) $300 \div 100 = 30 \div \dots$

e) $8 \times 3 = 4 \times \dots$

f) $10 \times 4 = 5 \times \dots$

g) $22 + 20 = 32 + \dots$

h) $45 - 22 = 35 - \dots$

i) $10 \div 2 = 20 \div \dots$

j) $16 \div 4 = 32 \div \dots$

k) $19 + 8 = 9 + \dots$

l) $27 - 16 = 17 - \dots$

Number Lines

L.4

Fill in the missing numbers on these number lines.

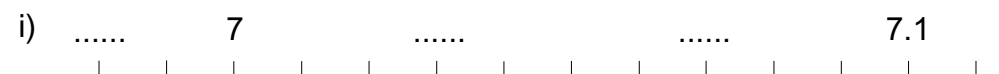
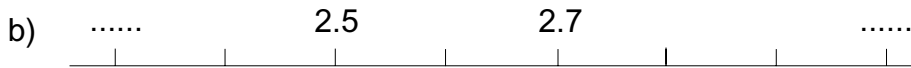

Putting Numbers into Order

L.4

Arrange these numbers into order of size, smallest number first.

Exercise 1

- a) 3, 23, 16, 14, 128
- b) 93, 74, 832, 2, 357
- c) 3.6, 7.4, 0.2, 6.7, 19.2
- d) 8.4, 9.0, 0.7, 4.1, 18.5
- e) 14.5, 3, 17, 27, 8.3
- f) 17, 4.5, 0.5, 73, 81
- g) 0.7, 9.5, 6.3, 7.5, 29
- h) 33.3, 5.7, 8, 9.2, 18.7
- i) 7.4, 6.3, 2, 71, 84.5
- j) 9.1, 5.3, 72.6, 9.4, 0.4

Exercise 2

- a) 3.56, 7.43, 4.85, 7.31, 1.43
- b) 8.34, 1.63, 9.64, 5.28, 7.54
- c) 8.0, 8.45, 6.45, 7.42, 8.43
- d) 3.65, 7.6, 8.52, 9.46, 6
- e) 12, 4.5, 6.0, 8.34, 27.5
- f) 4.87, 8.45, 9.7, 81.6, 9.53
- g) 9.63, 123, 5.67, 36.7, 74.0
- h) 34.85, 7.65, 3.9, 0.3, 71.5
- i) 16, 95.65, 8.65, 81, 9.76
- j) 5.81, 8.56, 13.29, 9.75, 0.38

Exercise 3

- a) 3.651, 7.405, 9.356, 8.297, 2.856
- b) 34.654, 9.765, 23.654, 9.769, 64.836
- c) 5.463, 5, 8.593, 6.243, 6
- d) 9.460, 6.386, 12.53, 4.7, 8.493
- e) 5.986, 7.65, 3.6, 9, 3.505
- f) 6.392, 7.8, 9.432, 0.138, 9.001
- g) 6.904, 2.7406, 8.651, 7.86, 0.8436
- h) 9, 3.765, 9.036, 786, 5.37
- i) 786.8, 9.054, 83.76, 76.65, 9.014
- j) 7, 0.98, 76.65, 3.56, 8.35
- k) 3.765, 0.001, 65.98, 3.56, 87.829

Magic Squares

L.4

This is a magic square.

Each of the 3 rows add up to 21.

Each of the 3 columns add up to 21.

Each of the 2 diagonals add up to 21.

8	9	4	→ 21
3	7	11	→ 21
10	5	6	→ 21
	↓	↓	↓
↙ 21	21	21	21
			↘ 21

Here are some more magic squares.

Decide what the rows, columns and diagonals add up to, then complete them.

a)

14		16
15		11
		12

b)

13		11
	14	
17	10	

c)

4		8
		1
	7	6

d)

13	8	
	12	
9	16	

e)

13	8	9
6		
		7

f)

9		
2	6	10
		3

g)

	19	
		17
18	11	16

h)

	2	3
0	4	8

i)

11	6	
4		
9	10	

j)

10	11	
5		
12		8

k)

		10
7		15
12		8

l)

	5	10
11	7	
4		

Making Numbers

L.4

These 4 cards can be put together to make bigger numbers.



For example, here are numbers made with 2 cards, 3 cards and 4 cards.

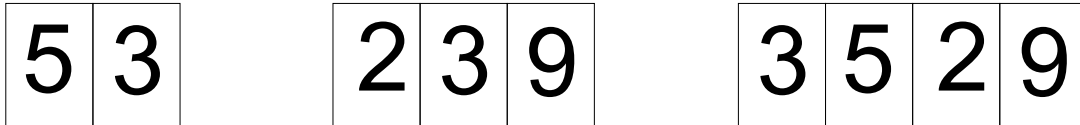

- What is the smallest number you can make with 2 cards?
- What is the largest number you can make with 4 cards?
- What is the difference between these two numbers?
- Explain why you can make more odd numbers than even numbers.
- Which 2 cards can make a square number?
- What 3 cards do you need to make the square of 23?
- Which card numbers are factors of 27?
- Write down a multiple of 5 made with 4 cards.

Here are some other ways of putting the numbers together.

$$\boxed{9} + \boxed{5} = 14 \quad \boxed{3} - \boxed{2} = 1$$

$$\boxed{5} \times \boxed{3} + \boxed{9} = 24$$

- How would you put 9 and 3 together to make 27?
- How would you put 3 and 5 together to make 2?
- Which two numbers can make 12?
- Which two numbers can make 18?
- How would you put together 3, 2 and 5 to make 10?
- How would you put together 3, 2 and 5 to make 0?
- How would you put together 3, 2 and 9 to make 15?
- How would you put together 9, 3 and 5 to get 6?
- Put together all 4 numbers to make 19.
- Put together all 4 numbers to make 1.
- Put together all 4 numbers to make 9.

Comparing

Do not use a calculator

L.4

< means 'is less than'

> means 'is greater than'

= means 'is equal to'

For example

$$4 > 2 \quad 6 < 8 \quad 3 + 2 = 4 + 1 \quad -3 = -5 + 2 \quad 6 + 7 > 7 - 5$$

1) Put one of these signs between each of the following.

a) $3 \dots\dots 6$

b) $6 \dots\dots 8$

c) $7 \dots\dots 4$

d) $3 \dots\dots 9$

e) $12 \dots\dots 24$

f) $-3 \dots\dots 7$

g) $-6 \dots\dots 0$

h) $2 \dots\dots -5$

i) $1 \dots\dots -7$

j) $-3 \dots\dots -2$

k) $-6 \dots\dots -1$

l) $0 \dots\dots -5$

m) $-3 \dots\dots 0$

n) $2 + 2 \dots\dots 5 - 1$

o) $6 - 7 \dots\dots 1$

p) $9 - 3 \dots\dots -6$

q) $3 - 6 \dots\dots -3 + 3$

r) $7 - 4 \dots\dots 4 - 1$

s) $11 + 2 \dots\dots 5 + 8$

t) $15 - 5 \dots\dots 5 + 5$

u) $14 + 3 \dots\dots 22 - 6$

v) $20 - 22 \dots\dots 22 - 20$

w) $13 + 14 \dots\dots 14 + 13$

x) $12 - 3 \dots\dots -12 + 3$

2) In each of these questions some of the + and - signs have been missed out.

Put in the correct signs.

a) $12 = 14 \dots\dots 2$

b) $6 = 4 \dots\dots 2$

c) $8 < 8 \dots\dots 1$

d) $3 \dots\dots 5 > 6$

e) $3 \dots\dots 2 = 2 \dots\dots 3$

f) $9 \dots\dots 5 < 5 \dots\dots 0$

g) $7 \dots\dots 1 < 8$

h) $5 \dots\dots 5 > 9$

i) $5 \dots\dots 1 = 6 - 0$

j) $3 \dots\dots 4 > 4 \dots\dots 3$

k) $7 \dots\dots 6 > 7 \dots\dots 6$

l) $5 \dots\dots 2 < 4 \dots\dots 1$

m) $4 \dots\dots 5 = -1$

n) $1 - 2 > 3 \dots\dots 5$

o) $7 - 9 > \dots\dots 3$

p) $4 \dots\dots 2 = 6$

q) $2 \dots\dots 4 = -2$

r) $5 - 8 = \dots\dots 3$

s) $12 \dots\dots 6 = 3 \dots\dots 3$

t) $\dots\dots 7 < \dots\dots 1$

u) $9 \dots\dots 5 > 9 \dots\dots 5$

v) $5 \dots\dots 5 > 12 \dots\dots 3$

w) $5 - 5 > 4 \dots\dots 5$

x) $3 \dots\dots 4 < 3 - 3$

y) $3 \dots\dots 4 = 4 \dots\dots 5$

z) $-4 \dots\dots 3 > -2$

Chain Rules

Do not use a calculator

L.4

1) Write down the next 3 numbers in these chains. In each case say what the rule is.

a) $\frac{1}{2} \longrightarrow \frac{1}{4} \longrightarrow \frac{1}{8} \longrightarrow \frac{1}{16} \longrightarrow$

b) $12 \longrightarrow 10\frac{1}{2} \longrightarrow 9 \longrightarrow 7\frac{1}{2} \longrightarrow$

c) $1\frac{1}{2} \longrightarrow \frac{3}{4} \longrightarrow \frac{3}{8} \longrightarrow \frac{3}{16} \longrightarrow$

2) Both these number chains begin with 2 and 4 but continue in a different way.

Rule

$2 \longrightarrow 4 \longrightarrow 6 \longrightarrow 8 \longrightarrow 10 \longrightarrow$ Add on 2 each time

$2 \longrightarrow 4 \longrightarrow 8 \longrightarrow 16 \longrightarrow 32 \longrightarrow$ Double the last number

Write down two different ways of continuing these number chains.

In both cases write down the next 3 numbers and say what the rule is.

a) $3 \longrightarrow 6 \longrightarrow \dots \longrightarrow \dots \longrightarrow \dots$

b) $1 \longrightarrow 2 \longrightarrow \dots \longrightarrow \dots \longrightarrow \dots$

c) $1 \longrightarrow 3 \longrightarrow \dots \longrightarrow \dots \longrightarrow \dots$

d) $20 \longrightarrow 10 \longrightarrow \dots \longrightarrow \dots \longrightarrow \dots$

e) $8 \longrightarrow 4 \longrightarrow \dots \longrightarrow \dots \longrightarrow \dots$

f) $9 \longrightarrow 3 \longrightarrow \dots \longrightarrow \dots \longrightarrow \dots$

g) $-1 \longrightarrow -2 \longrightarrow \dots \longrightarrow \dots \longrightarrow \dots$

h) $-8 \longrightarrow -4 \longrightarrow \dots \longrightarrow \dots \longrightarrow \dots$

i) $-3 \longrightarrow -9 \longrightarrow \dots \longrightarrow \dots \longrightarrow \dots$

j) $2 \longrightarrow 1 \longrightarrow \dots \longrightarrow \dots \longrightarrow \dots$

Mental Arithmetic

Do not use a calculator

L.4

- 1) Mohinder adds together 27 and 31 in her head.

She does it like this:-

$$\begin{aligned} 27 + 31 &= 20 + 7 + 30 + 1 \\ &= 20 + 30 + 7 + 1 \\ &= 50 + 8 \\ &= 58 \end{aligned}$$

Write down how she would add together 27 and 42

Write down how she would add together 43 and 56

- 2) Huw adds together 27 and 31.

He does it like this:-

$$\begin{aligned} 27 + 1 &= 28 \\ 28 + 30 &= 58 \end{aligned}$$

Write down how he would add together 16 and 37

Write down how he would add together 53 and 44

- 3) Alan subtracts 24 from 87 in his head.

He does it like this:-

$$\begin{aligned} 80 - 20 &= 60 \\ 7 - 4 &= 3 \\ 60 + 3 &= 63 \\ \text{So } 87 - 24 &= 63 \end{aligned}$$

Write down how he would subtract 36 from 89

Write down how he would subtract 63 from 97

- 4) Lucy subtracts 27 from 84 by using the 'counting on' method in her head.

This is what she does:-

$$\begin{aligned} 27 \text{ to } 30 &\text{ is } 3 \\ 30 \text{ to } 80 &\text{ is } 50 \\ 80 \text{ to } 84 &\text{ is } 4 \\ \text{Adding these together gets } &57 \\ \text{So } 84 - 27 &= 57 \end{aligned}$$

Write down how she would subtract 27 from 51

Write down how she would subtract 48 from 93

- 5) Lucy says that the 'counting on' method can be used for any subtraction.

Write down how you would do these using the 'counting on' method.

a) $44 - 19$

b) $73 - 25$

c) $48 - 24$

d) $53 - 21$

e) $87 - 26$

f) $43 - 29$

g) $76 - 37$

h) $67 - 39$

Tests for Dividing

Do not use a calculator

L.4

- 1) a) Which of these numbers will 2 divide into exactly?
4, 5, 7, 11, 13, 14, 15, 17, 20, 21, 25, 26, 29, 34.
- b) Which of these numbers will 5 divide into exactly?
5, 6, 9, 10, 13, 14, 15, 19, 25, 31, 37, 40, 44, 46, 50.
- c) Which of these numbers will 10 divide into exactly?
8, 10, 12, 17, 20, 31, 40, 42, 50, 60, 71, 79, 80, 90.
- 2) Jane has a rule for testing whether 3 divides exactly into a number. This is what she does.

To test 48

First add together the 4 and the 8 to get 12.

Now add together the 1 and the 2 to get 3.

Because the answer is 3 then 3 will divide exactly into 48.

The rule is 'If the answer is 3, 6 or 9 then 3 will divide exactly'

To test 46

$$4 + 6 = 10$$

$$1 + 0 = 1$$

So 3 will not divide exactly into 46

To test 87

$$8 + 7 = 15$$

$$1 + 5 = 6$$

So 3 will divide exactly into 87

Write down what you would do to test whether 3 will divide exactly into these.

a) 73

b) 68

c) 72

d) 94

e) 81

- 3) Jane says that this rule works for 9 also. But this time the answer must always be 9.

She tests 83 this way

$$8 + 3 = 11$$

$$1 + 1 = 2$$

So 83 is not divisible by 9.

She tests 99

$$9 + 9 = 18$$

$$1 + 8 = 9$$

So 99 is divisible by 9.

Write down what you would do to test these.

a) 56

b) 108

c) 127

d) 257

e) 491

Tens, Hundreds and Whole Numbers

Do not use a calculator

L.4

- 1) Postage stamps are made in sheets of 200. Each row has 10 stamps in it.

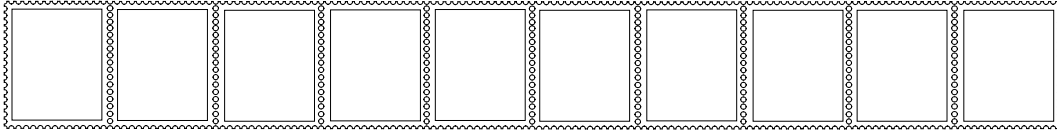

- a) How many rows are there on a sheet of stamps?

Graham asks the counter clerk in the post office for 45 second class stamps. She gives him 4 rows of stamps and 5 more.

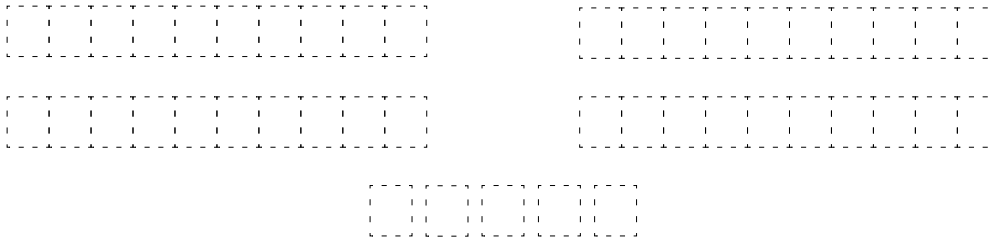

- b) Karen asks for 73 stamps. How many rows and how many single stamps is she given?
- c) At the end of the day, the counter clerk has sold 3 sheets and 2 rows of second class stamps. How many stamps is this?
- 2) Dave has 143 marbles to share amongst himself and 9 friends. They each get the same number of marbles except for Dave who also gets the ones left over. How many marbles will Dave get?
- 3) a) Which of these numbers is exactly divisible by 10?
26, 50, 68, 94, 110, 130, 251, 826, 900, 1200, 3,560
- b) How many will be left over when these quantities are shared equally between 10 people?
39, 53, 94, 126, 243, 562, 678, 741, 822, 910, 1548
- c) Which of these numbers is exactly divisible by 100?
156, 300, 542, 687, 910, 1000, 1200, 1250, 1341, 2341
- d) How many will be left over when these quantities are shared equally between 100 people?
121, 572, 836, 1422, 2426, 3,421, 9462, 10,462, 11,751, 15,342
- 4) The distance from Densil's town to London is 350 miles. He sets off to London by car.
- a) How far has he gone when he has travelled $\frac{1}{10}$ of the journey?
- b) How far has he gone when he has travelled $\frac{7}{10}$ of the journey?

Tens, Hundreds and Decimals

Do not use a calculator

L.4

- 1) A piece of string measures 140cm. It is cut into 10 equal lengths. How long will each piece be?
- 2) A path is laid down a garden. It is made from paving stones which measure 60cm square.

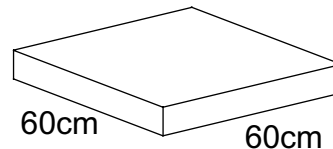

- a) If 10 of these are laid end to end, what will be their total length?

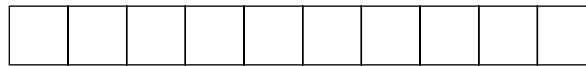

- b) If 20 of these are laid end to end, what will be their total length?
 - c) The path is 25 paving stones long. How long is the path? Give your answer in metres.
- 3) The cost of a pen is 16p.
 - a) What is the cost of 10 pens?
 - b) What is the cost of 100 pens?
 - c) A school shop orders 260 pens. How much will they cost?
 - 4) Each of these lengths are cut into 10 equal pieces. Write down how long they are.
 - a) 27cm b) 38cm c) 52cm d) 85cm e) 124cm f) 256cm g) 594cm
 - 5) Each of these lengths are cut into 100 equal pieces. Write down how long they are.
 - a) 128cm b) 341cm c) 562cm d) 481cm e) 756cm f) 941cm g) 5426cm
 - 6) Hannah lives 65 miles from Belfast. She travels to the city by bus. It takes her 2 hours to get there.

After 12 minutes she estimates that she has travelled $\frac{1}{10}$ of the journey. How many miles of the journey does she think she has left?
 - 7)
 - a) What is $100 \times \text{£}1.31$?
 - b) Use the answer to part 'a' to calculate $600 \times \text{£}1.31$.
 - c) What is $10 \times \text{£}1.31$?
 - d) Now calculate $620 \times \text{£}1.31$
 - 8) Use your knowledge of multiplying by 10 and 100 to calculate these.
 - a) $250 \times \text{£}2.46$ b) $310 \times \text{£}3.76$ c) $540 \times \text{£}6.53$
 - 9)
 - a) What is $\text{£}380 \div 100$?
 - b) Use your answer to part 'a' to calculate $\text{£}380 \div 400$

Position

L.4

1)

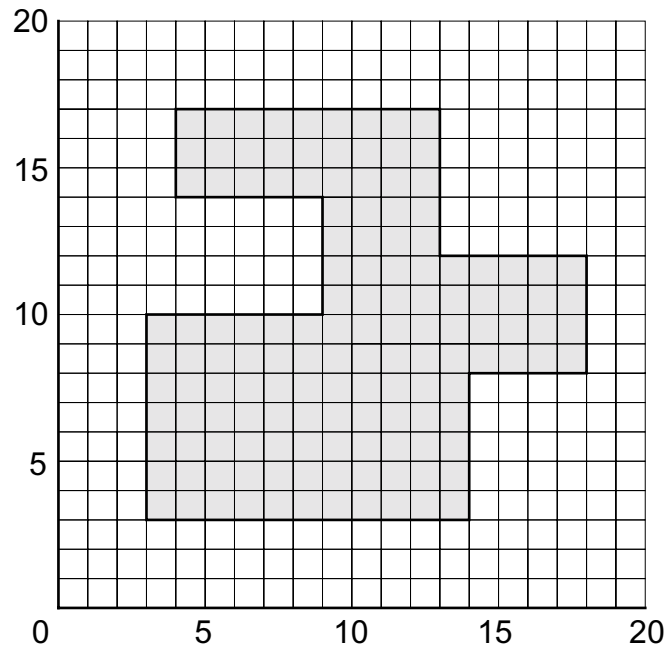

Write down the co-ordinates of the corners of this shape.

2)

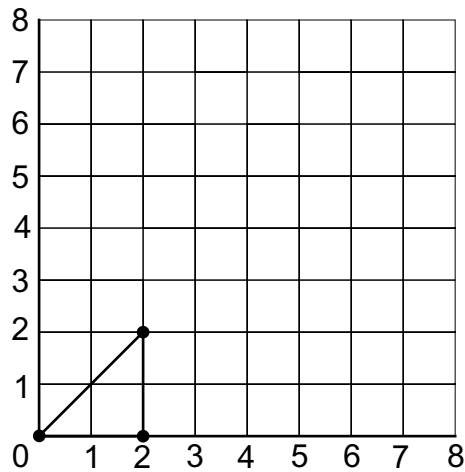

The co-ordinates of this triangle are (0,0), (2,0) and (2,2)

- Draw this triangle on squared paper.
- Multiply each of the co-ordinates by 2. Draw the new triangle on a separate piece of squared paper.
- The co-ordinates of the first triangle are multiplied by another number. If one of the points is (6,6), what is the number multiplied by?
- In part c), what are the other co-ordinates? Draw the new triangle on a separate piece of squared paper.

Co-ordinates

L.4

- 1) a) On squared paper plot these co-ordinates.
A(2,1), B(2,6), C(3,6), D(3,4), E(4,4), F(4,6), G(5,6), H(5,1), I(4,1), J(4,3), K(3,3)
and L(3,1)
 - b) Now join together the points, A to B to C to D to E to F to G to H to I to J to K to L to A.
 - c) Now shade in the shape you have formed. What letter of the alphabet is this?
- 2) Three corners of a square are represented by the points (3,0), (1,2), and (3,4).
Plot these points on a sheet of squared paper. What are the co-ordinates of the fourth corner?
 - 3) Three co-ordinates of a parallelogram are (1,1), (4,1) and (3,4). What are the co-ordinates of the fourth corner? There are two answers.
 - 4) The diagram shows part of a letter H. Complete the diagram.

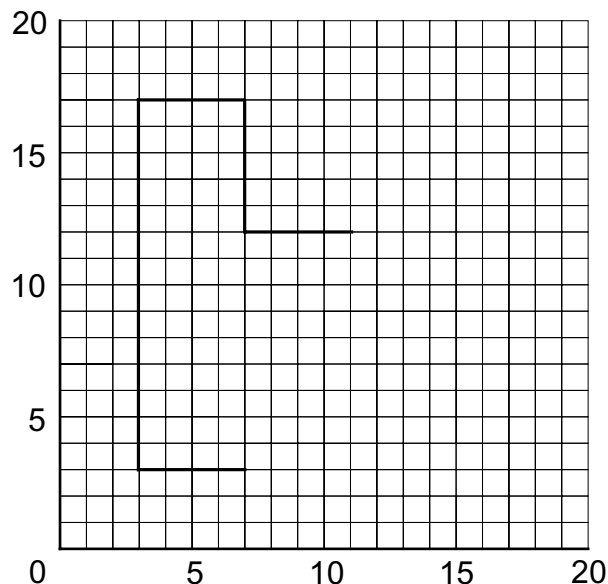

What are the co-ordinates of the other corners?

- 5) The co-ordinates of a square are (0,3), (2,5), (4,3) and (2,1).
On a sheet of squared paper, plot these points and draw the square.
The co-ordinates of another square are twice the value of the first square.
These are (0,6), (4,10), (8,6) and (4,2).
On the same sheet of squared paper plot these points and draw the square.
How many of the small squares will fit into the larger one?
- 6) Some of the corners of a capital letter M are the co-ordinates (5,3), (3,6), (3,2), (2,2), (2,8), (3,8), and (5,5).
On squared paper plot these points. Join them together in the order given.
Finish off the letter M
What are the co-ordinates of the remaining corners?

Number Patterns

L.4

- 1) The diagram shows a series of patterns made from one triangular tile surrounded by square tiles. Each new pattern has more tiles than the one before it.

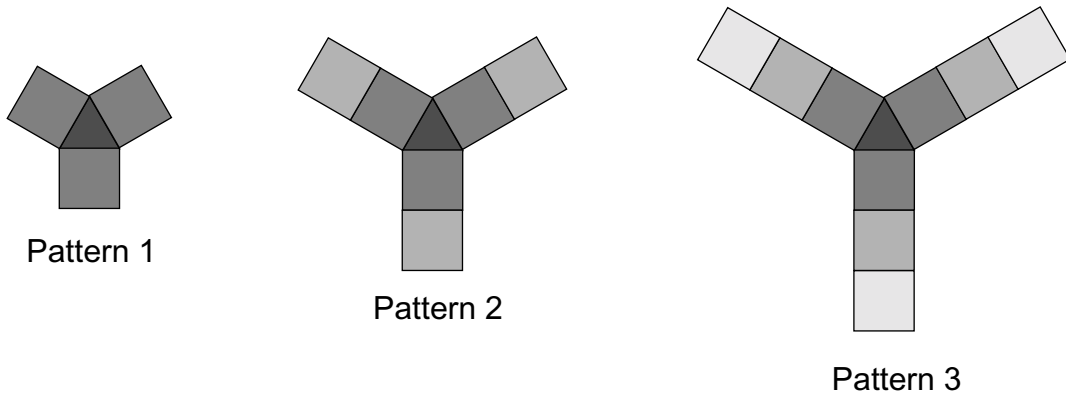

- How many more square tiles does each new pattern have?
- How many square tiles will pattern 4 have?
- How many square tiles will there be in pattern number 10?
- Say in words how you calculate the number of square tiles in a pattern.

- 2) The diagram shows a series of patterns made from square tiles. The tiles are made into square patterns.

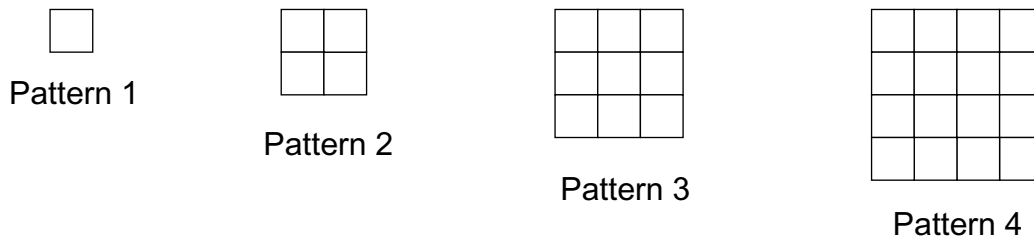

- How many tiles will be needed to make pattern 5?
- How many tiles will be needed for pattern 10?
- Say in words how you calculate the number of tiles in a pattern.

- 3) The diagram shows a series of patterns made up from matchsticks.

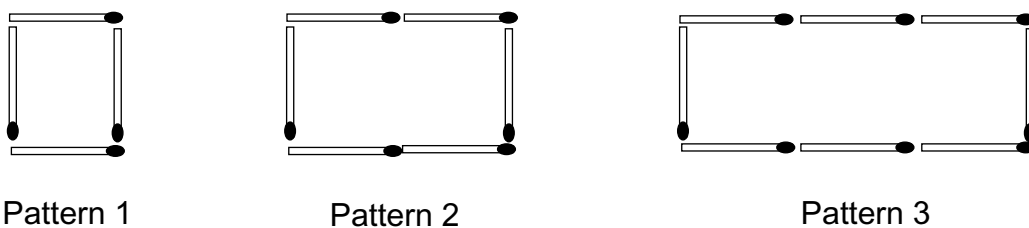

- How many more matchsticks are added each time?
- How many matchsticks will be in pattern 4?
- How many matchsticks will be in pattern 10?
- Say in words how you calculate the number of matchsticks in a pattern.

Number Machines

L.4

- 1) George sells DVD discs. He doesn't have a shop but he sells them through the post. He sells each disc for £15. He also charges a fixed price of £5 for postage and packing.

So 1 disc costs £15 + £5 = £20

2 discs cost £30 + £5 = £35

and so on

The table shows how much he charges.

Number of Discs	Price
1	20
2	35
3	50
4	
5	
6	

- a) Complete the table for 4, 5 and 6 discs.

George uses this table to work out how much to charge his customers.

When someone has a very big order he uses this number machine to work out how much to charge.

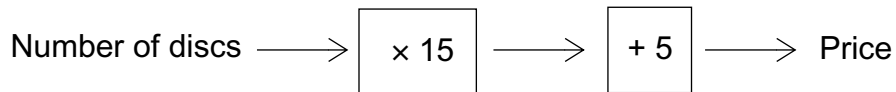

- b) Use this number line to calculate the cost of
 - (i) 10 discs
 - (ii) 15 discs
 - (iii) 20 discs

Here are some more number machines. Use them to calculate the number that comes out each time.

- 2)

Number in \longrightarrow $\boxed{+ 2}$ \longrightarrow $\boxed{\times 3}$ \longrightarrow Number out

Numbers in a) 3 b) 12 c) 18

- 3)

Number in \longrightarrow $\boxed{\times 2}$ \longrightarrow $\boxed{+ 3}$ \longrightarrow Number out

Numbers in a) 3 b) 8 c) 15

- 4)

Number in \longrightarrow $\boxed{+ 2}$ \longrightarrow $\boxed{\times 2}$ \longrightarrow $\boxed{- 2}$ \longrightarrow Number out

Numbers in a) 5 b) 7 c) 9

Angles Between

L.4

1) The diagram shows the four points of the compass.

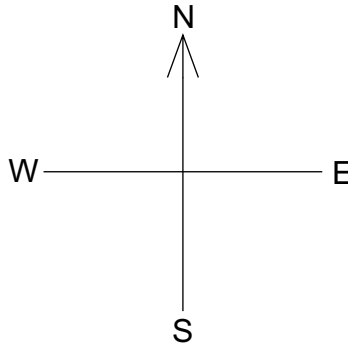

- What is the size of the angle between North(N) and South(S)?
- What is the size of the angle between North(N) and East(E)?
- The direction that is halfway between North and West is called North West(NW).
What is the size of the angle between NW and N?
- What is the size of the angle between W and NW?
- The direction half way between South and East is called South East(SE).
What is the size of the angle between South and SE?
- What is the size of the angle between North and SE?
- What is the size of the angle between NW and SE?

2) The diagram shows a clock. The hands are pointing to 9 o'clock.

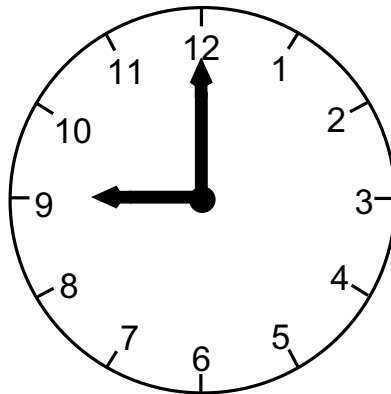

- What is the angle between the hands when the clock reads 9 o'clock?
- What is the angle between the hands when the clock reads 11 o'clock?
- What is the angle between the hands when the clock reads 10 o'clock?
- The time changes from 10 o'clock to 11 o'clock.
How many degrees does the hour hand (small hand) travel through?
- What is the size of the angle between the hands at 8 o'clock?
- What is the size of the angle between the hands at 7 o'clock?
- How many degrees does the minute hand travel through between 9:15 and 9:30?
- How many degrees does the minute hand travel through between 9:15 and 9:50?
- How long does it take for the minute hand to travel 180° ?

Turning Patterns

L.4

1)

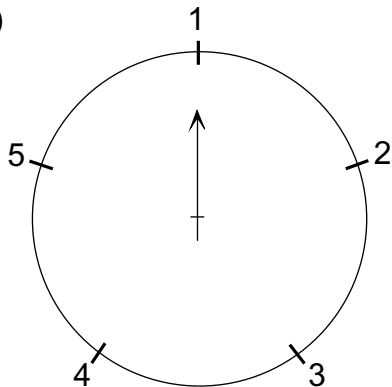

This pointer begins at point 1. It turns clockwise. It rotates $\frac{2}{5}$ turn each time.

It's number pattern is like this

1 3 5

- Continue this number pattern until you reach the next 5
- Beginning at 1, write down the number pattern for a turn of $\frac{3}{5}$. Continue until you reach the second 4
- What type of turn does this number pattern show?

5 4 3

2)

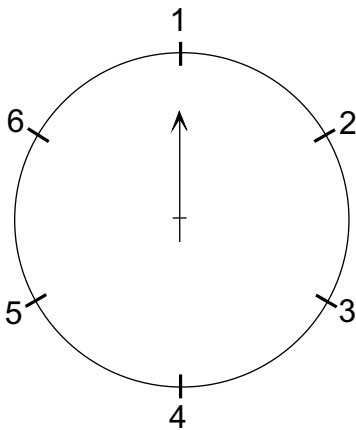

This pointer begins at point 1. It turns clockwise. It rotates $\frac{5}{6}$ turn each time.

It's number pattern is like this

1 6 5

- Continue this number pattern until you reach the next 5
- Beginning at 1, write down the number pattern for a turn of $\frac{2}{3}$. Continue until you reach the second 5
- What type of turn does this number pattern show?

1 4 1

3)

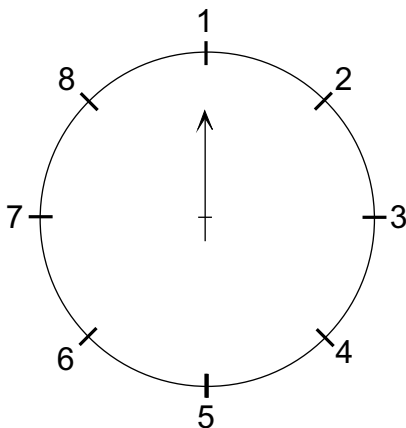

This pointer begins at point 1. It turns clockwise. It rotates $\frac{3}{8}$ turn each time.

It's number pattern is like this

1 4 7

- Continue this number pattern until you reach the next 7
- Beginning at 1, write down the number pattern for a turn of $\frac{5}{8}$. Continue until you reach the second 3
- What type of turn does this number pattern show?

1 8 7

Reflections

L.4

Copy each of the following onto square dotted paper.

Reflect the shape about the dotted line then draw in this reflection.

The grid contains the following shapes and reflection lines:

- 1. A shape with vertices at (2,3), (2,4), (3,4), (3,5), (4,5), (4,3), (3,3), (2,3) and a vertical dotted line at x=4.
- 2. A shape with vertices at (4,3), (4,4), (5,4), (5,5), (6,5), (6,3), (5,3), (4,3) and a vertical dotted line at x=5.
- 3. A shape with vertices at (7,3), (7,4), (8,4), (8,5), (9,5), (9,3), (8,3), (7,3) and a vertical dotted line at x=7.
- 4. A shape with vertices at (2,5), (2,6), (3,6), (3,7), (4,7), (4,5), (3,5), (2,5) and a vertical dotted line at x=2.
- 5. A shape with vertices at (4,5), (4,6), (5,6), (5,7), (6,7), (6,5), (5,5), (4,5) and a vertical dotted line at x=5.
- 6. A shape with vertices at (7,5), (7,6), (8,6), (8,7), (9,7), (9,5), (8,5), (7,5) and a vertical dotted line at x=7.
- 7. A shape with vertices at (2,7), (2,8), (3,8), (3,9), (4,9), (4,7), (3,7), (2,7) and a vertical dotted line at x=2.
- 8. A shape with vertices at (4,7), (4,8), (5,8), (5,9), (6,9), (6,7), (5,7), (4,7) and a vertical dotted line at x=5.
- 9. A shape with vertices at (7,7), (7,8), (8,8), (8,9), (9,9), (9,7), (8,7), (7,7) and a vertical dotted line at x=7.
- 10. A shape with vertices at (2,2), (3,2), (3,3), (4,3), (4,2), (2,2) and a diagonal dotted line from (2,2) to (4,4).
- 11. A shape with vertices at (4,2), (5,2), (5,3), (6,3), (6,2), (4,2) and a diagonal dotted line from (4,2) to (6,4).
- 12. A shape with vertices at (7,2), (8,2), (8,3), (9,3), (9,2), (7,2) and a diagonal dotted line from (7,2) to (9,4).

Rotation

L.4

- 1) Diagram A shows a triangle rotated through 90° clockwise about corner a. Draw the rotation of triangle B with point 'b' staying in the same place.

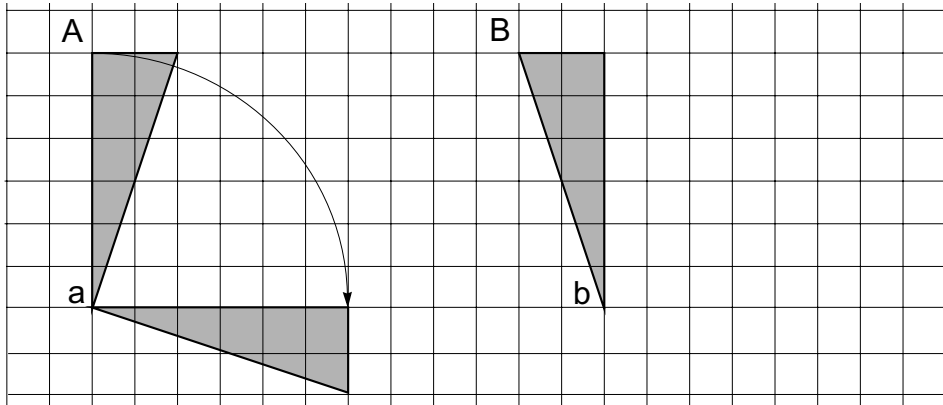

- 2) Rotate the two shapes below through 90° clockwise. Ensure points 'a' and 'b' stay in the same place.

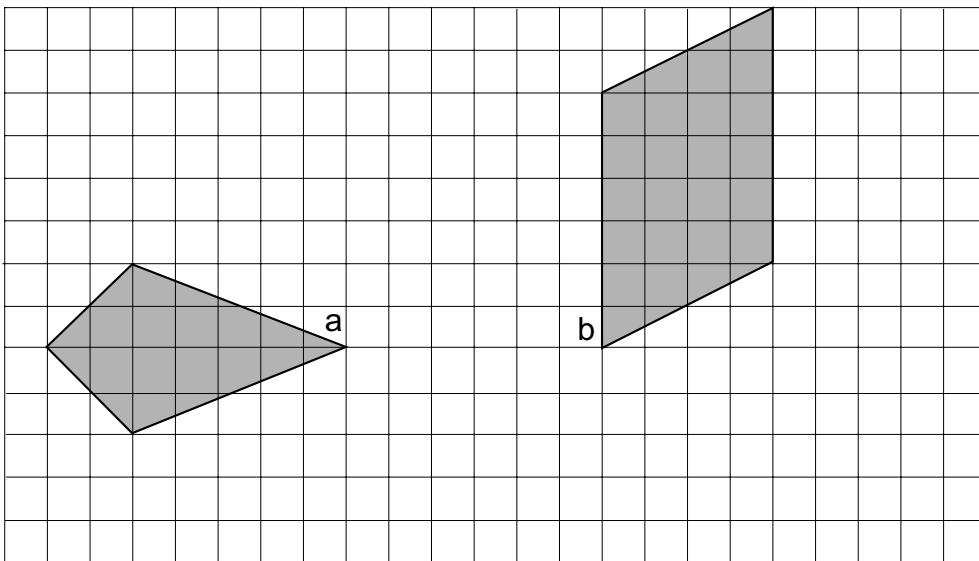

- 3) Rotate shape A 90° anticlockwise about point 'a' and shape B 90° clockwise about point 'b'. Draw the new shapes.

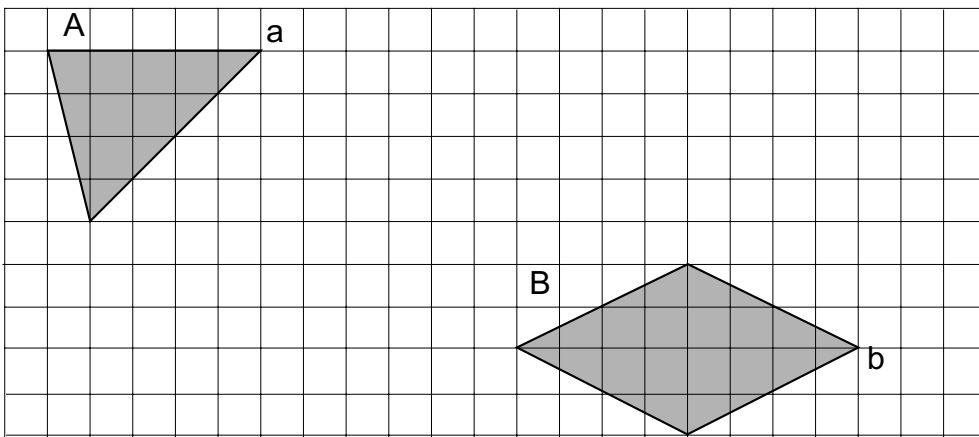

Volume of a Cuboid

L.4

Each cuboid below has been made from smaller cubes.
How many cubes make up each cuboid?

a)

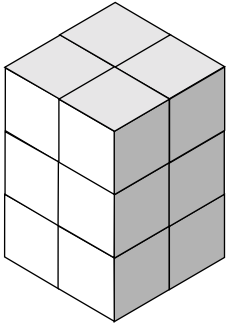

b)

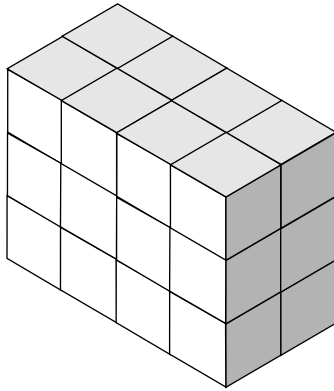

c)

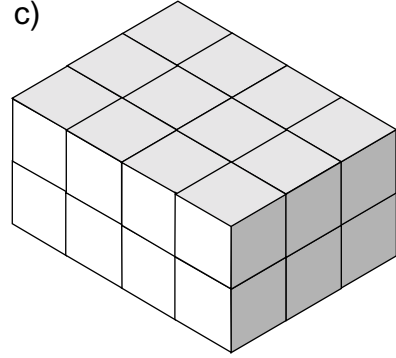

d)

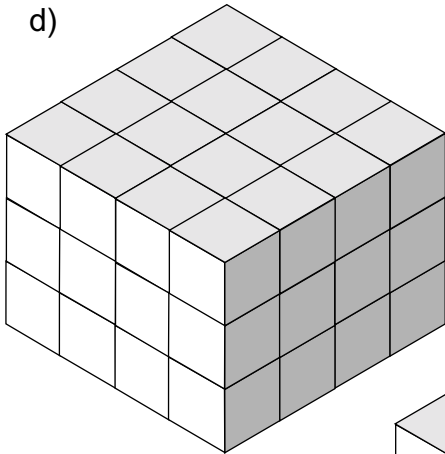

e)

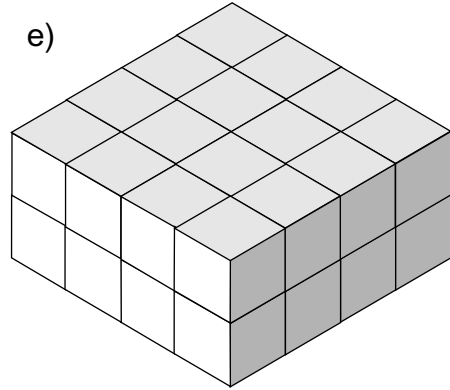

f)

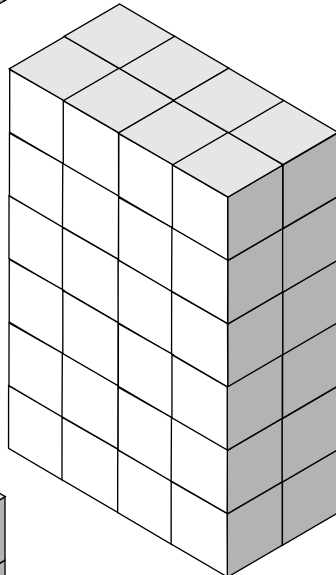

g)

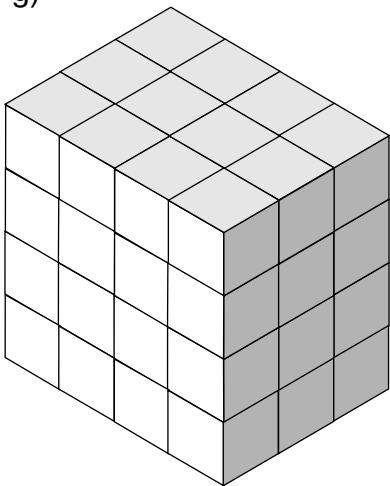

h)

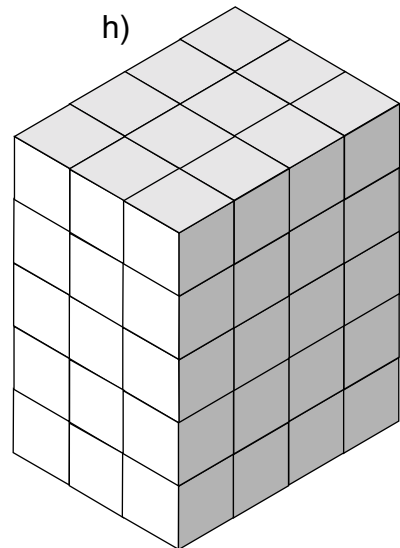

Volume of a Shape

L.4

Each of the diagrams below have been made from two cuboids.
How many small cubes are there in each shape?

a)

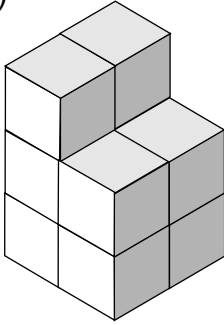

b)

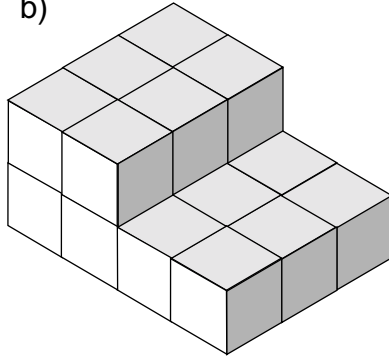

c)

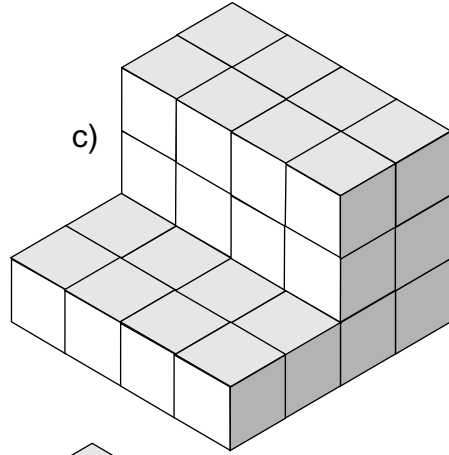

d)

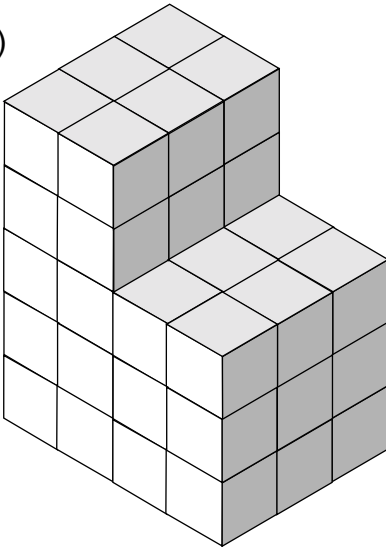

e)

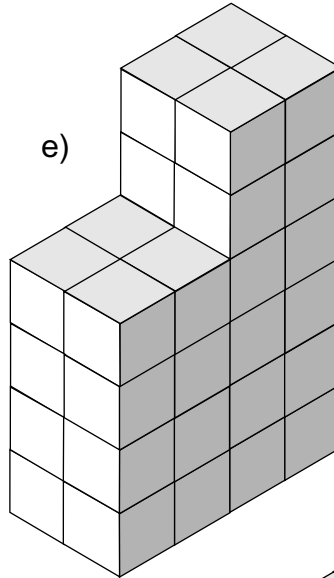

f)

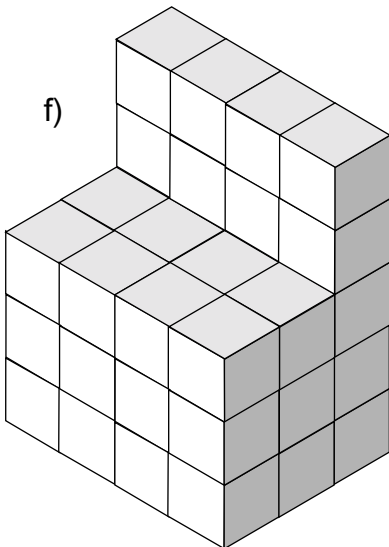

g)

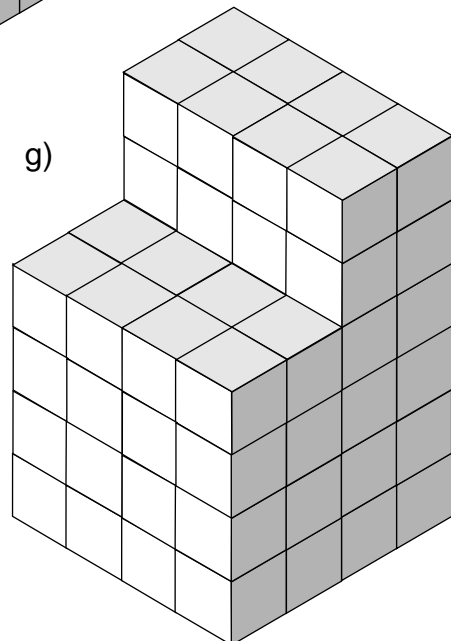

Packing Boxes

L.4

- 1) Zoe puts boxes of chocolates into larger packs. A pack holds 5 boxes along its length and 6 boxes along its width.

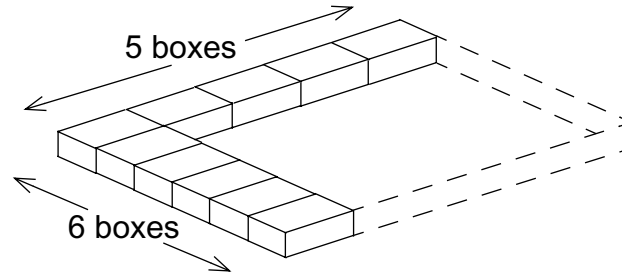

- a) How many boxes will cover the bottom of the pack?

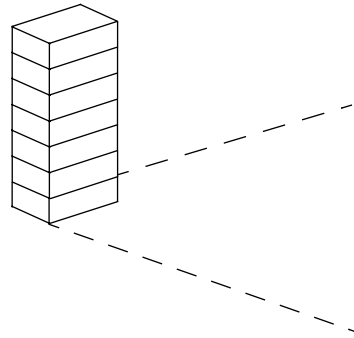

The pack holds 7 layers of boxes.

- b) How many boxes will fit into the pack when it is full?
- 2) Nigel is putting packs of orange juice into a box. The box will hold 5 packs along its length, and 5 packs along its width. The box will hold 5 layers of packs.

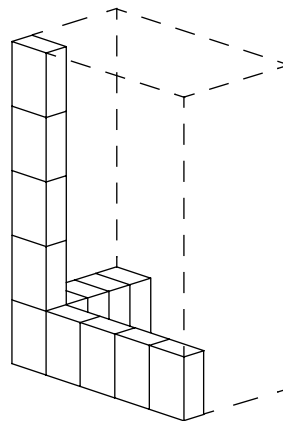

How many packs will it hold altogether?

- 3) Another box will hold 6 packs across and is 4 packs wide. When full it will hold 7 layers. How many packs will the box hold?
- 4) A box is filled with tins of baked beans. It will hold 4 layers of tins. Each layer is 8 tins long and 6 tins wide. How many tins will the box hold?

Area and Perimeter

L.4

1) (i) By counting squares, say what the area of each diagram is.

(ii) What is the perimeter of each shape?

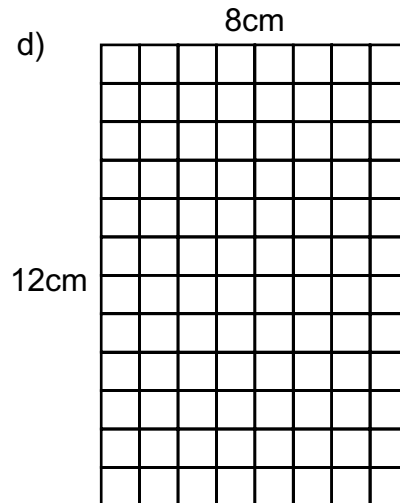
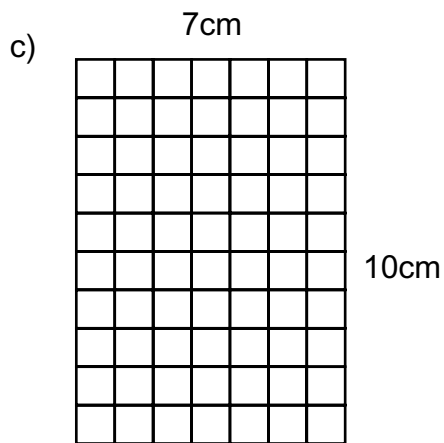
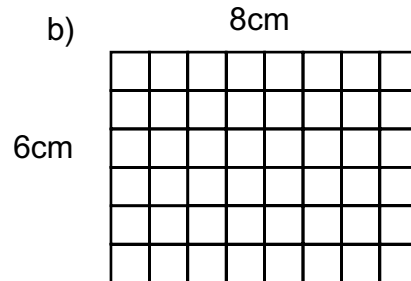
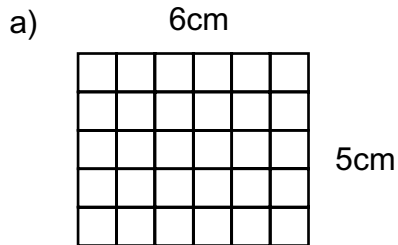

2) By counting squares, estimate the area of these leaves.

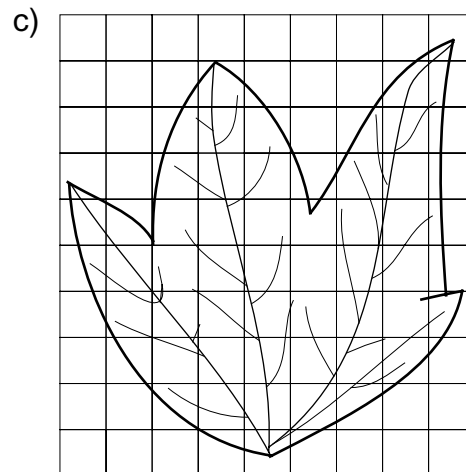
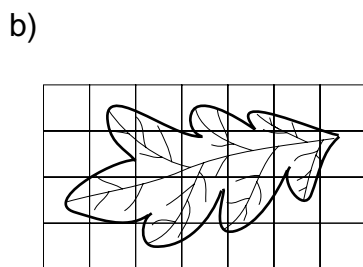
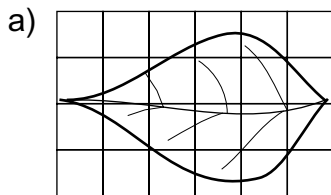

Measuring Lines

L.4

In each of the following diagrams, say what number the arrow is pointing to.

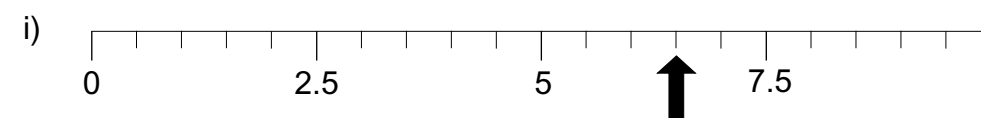
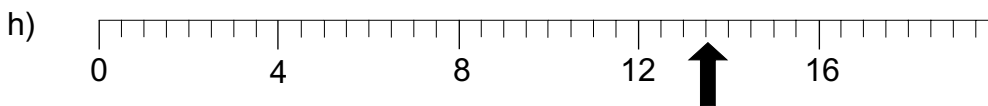
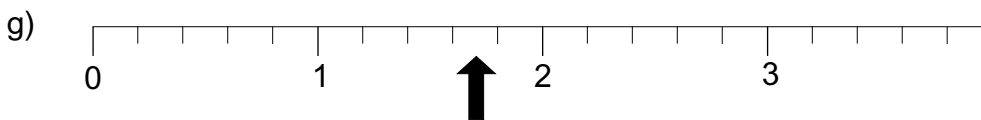
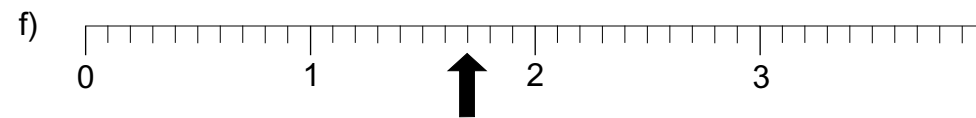
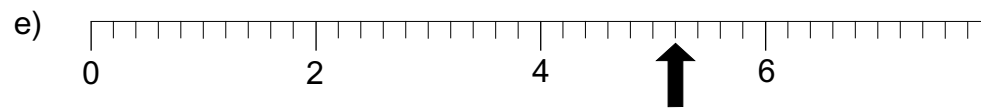
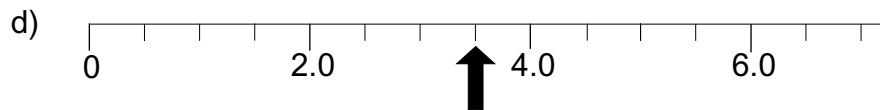
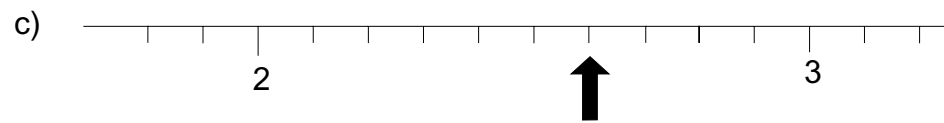
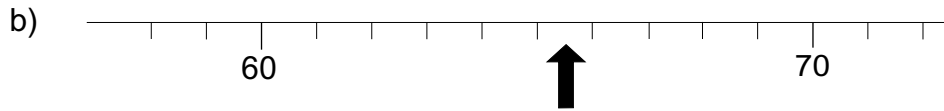
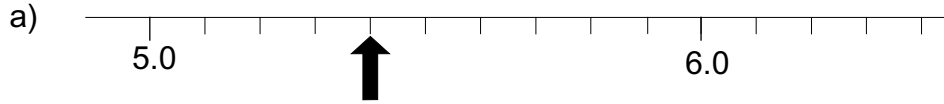

Measuring Instruments

L.4

1) What amounts of water have been put into these jugs?

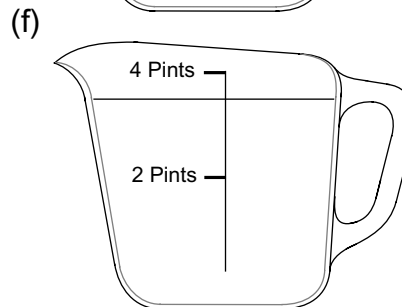
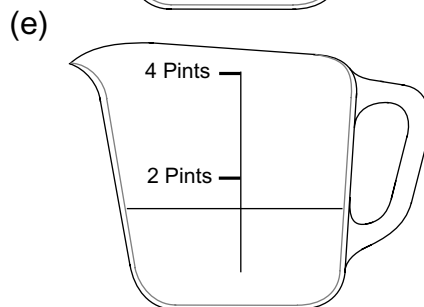
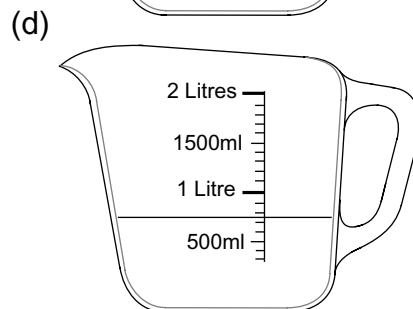
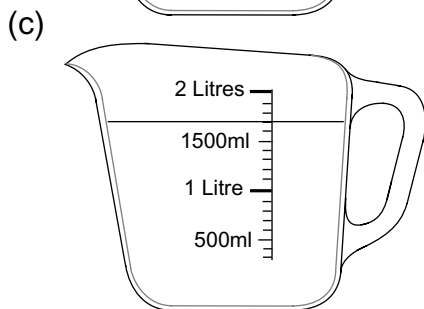
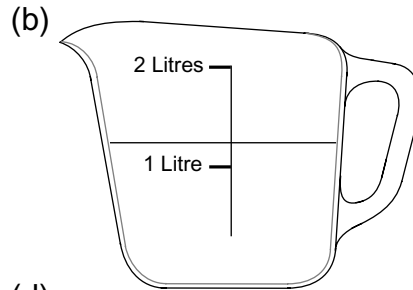
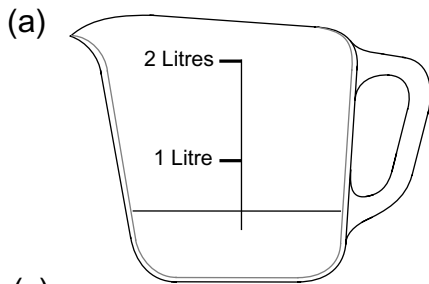

2) Mr. and Mrs. Jones have two daughters, Helen and Laura. Helen is 15 years old and Laura is 11. All four weigh themselves on the bathroom scales. Mr. Jones is the heaviest. Mrs. Jones is the next heaviest and Laura is the lightest. Use these scales to say how much each weigh.

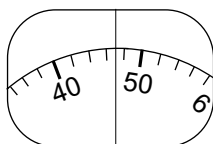

(a)

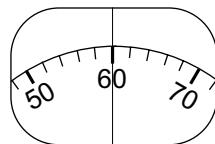

(b)

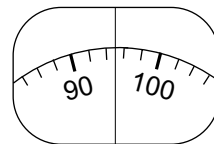

(c)

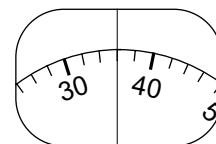

(d)

3) What weights do the following scales show?

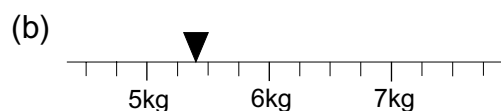
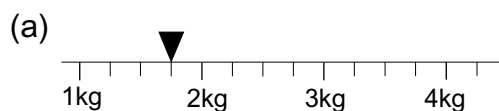

Measuring Lengths

L.4

1)

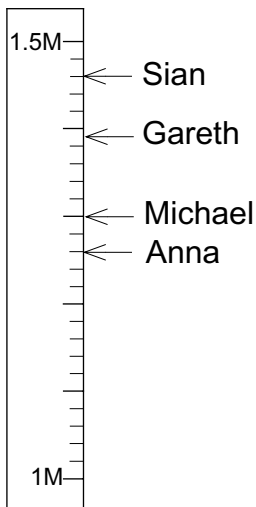

On the classroom wall is a measuring stick. It shows the heights that are between 1 metre and 1.5 metres above the floor. Sian, Gareth, Anna and Michael stand next to the stick and mark off their heights.

- a) What are the heights of the four children?
- b) How much taller than Anna is Sian?

2) Bill measures the lengths of his three pencils. What do they each measure?

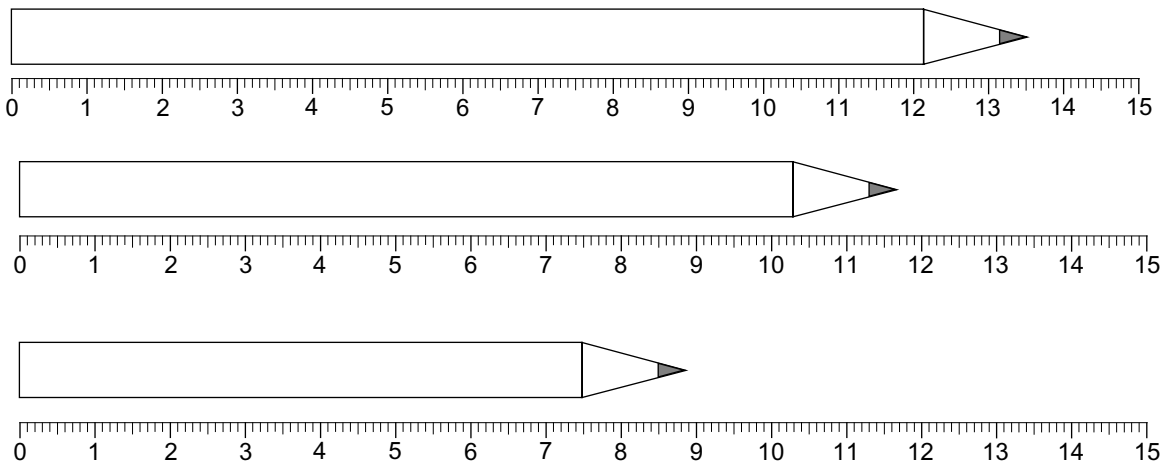

3) Sam has a broken ruler. What are the lengths of her pencils?

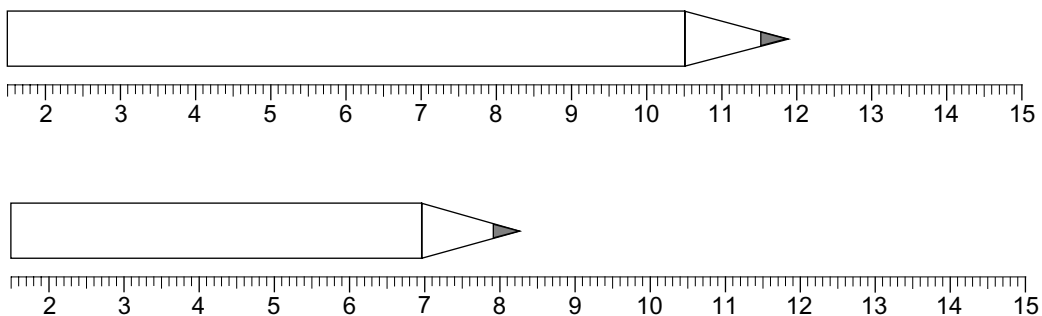

Adding Time

L.4

1) The diagram below shows the result when 15 minutes is added on to 12:00.

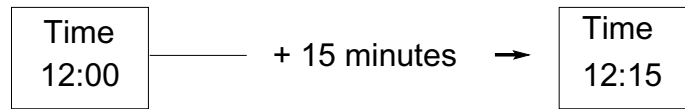

Fill in the blanks in these time intervals

- a)

11:00	—	+ 10 minutes	→
-------	---	--------------	---	-------
- b)

7:00	— minutes	→	7:25
------	---	---------------	---	------
- c)

.....	—	+ 17 minutes	→	7:37
-------	---	--------------	---	------
- d)

0:30	—	+ 25 minutes	→
------	---	--------------	---	-------
- e)

13:45	— minutes	→	14:05
-------	---	---------------	---	-------
- f)

18:35	—	+ 25 minutes	→
-------	---	--------------	---	-------
- g)

6:45	— minutes	→	7:15
------	---	---------------	---	------
- h)

15:23	—	+ 2 hour 15minutes	→
-------	---	--------------------	---	-------
- i)

.....	—	+ 1 hour 5 minutes	→	12:32
-------	---	--------------------	---	-------
- j)

20:36	—	+ hour minutes	→	23:00
-------	---	--------------------------	---	-------
- k)

1:47	—	+ 3 hour 20 minutes	→
------	---	---------------------	---	-------
- l)

15:38	—	+ hour minutes	→	17:05
-------	---	--------------------------	---	-------
- m)

.....	—	+ 2 hour 3 minutes	→	12:10
-------	---	--------------------	---	-------
- n)

7:50	—	+ 3 hour 13 minutes	→
------	---	---------------------	---	-------

Making Areas

L.4

A garden centre sells paving stones to make patios. The square paving stones are in three sizes

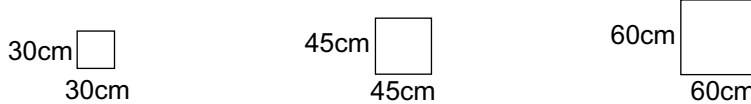

The 30cm size cost £1 each, the 45cm size cost £1.60 each and the 60cm size cost £2.50 each

- 1) A 60cm paving stone is to be completely surrounded by 30cm paving stones.
- a) How many 30cm paving stones will be needed?

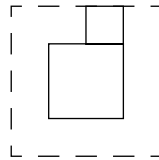

- b) Mr. Singh makes a patio with 60cm and 30cm paving stones.
- He puts down eight 60cm paving stones with 30cm paving stones surrounding them. Like this.

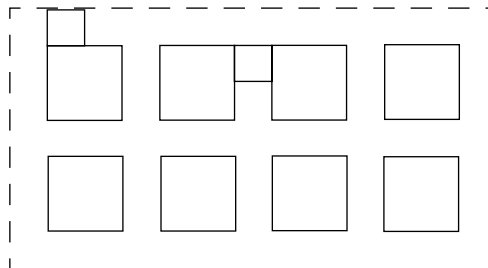

- (i) How many 30cm paving stones will he need?
- (ii) What will be the cost of his paving stones?
- 2) Mrs. Lee uses 60cm, 45cm and 30cm paving stones, like this, to make her patio.

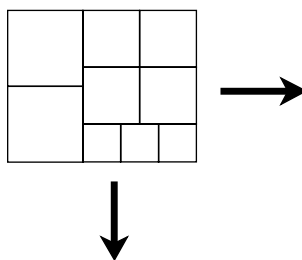

She repeats this pattern until she has covered an area measuring 240cm by 450cm.

- a) How many paving stones of each size will she need?
- b) What will be the cost of the paving stones?

Years

L.4

- 1) Joe's gran celebrates her 60th birthday on 16th July 2000. In what year was she born?
- 2) Joe's grandad celebrates his 64th birthday on 19th November 2000. In what year was he born?
- 3) On 26th August 2000, Joe's gran and grandad both filled out a form. They had to write down their age on that day. How old were they?
- 4) Joe was born on 22nd August 1995.
 - a) When will Joe celebrate his 12th birthday?
 - b) Joe's sister is exactly 2 years and 2 months older than Joe. When was she born?
- 5) The 50th anniversary of the end of the Second World War was celebrated in 1995.
 - a) In what year did the Second World War end?
 - b) In what year will the 75th anniversary occur?
- 6) The Battle of Hastings took place in 1066. In what year will the 950th anniversary take place?
- 7) Ann was born 27th September 1994. Her dad is exactly 26 years older than her.
 - a) When was he born?
 - b) In what year will Ann be 26?
- 8) Sue was born on 24th May 1994. Her brother is exactly 18 months older than her. When was he born?
- 9) Jill's birthday is on 11th April. She was 11 when she started at her secondary school in September of year 7.
 - a) How old was she at the beginning of year 11?
 - b) How old was she when she finished school at the end of year 11?
- 10) Lin's mum bought a car on 20th July 1999 and sold it exactly 18 months later. When did she sell it?

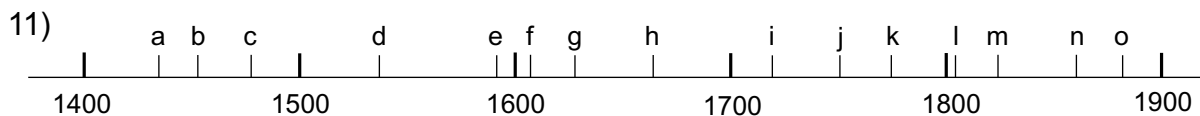

On this date line, say which letters represent these events.

- (i) The Great Fire of London in 1666
- (ii) Industrial Revolution begins in 1750
- (iii) First Boer War begins in 1880
- (iv) Joan of Arc killed by the English in 1431
- (v) William Caxton sets up a printing press in 1476
- (vi) The Spanish Armada was defeated in 1588

Bars

L.4

1) The diagram below shows the number of brothers and sisters of the pupils in 9Y.

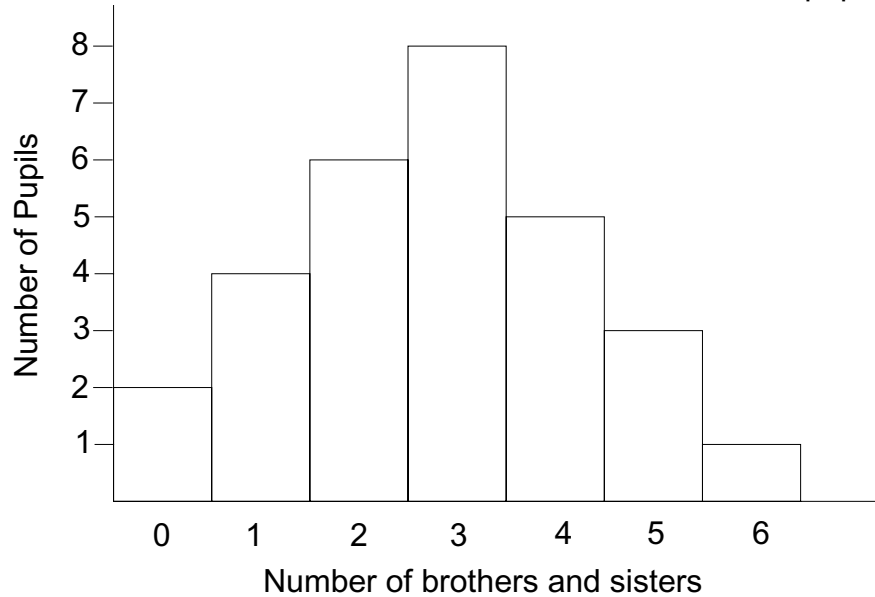

For example, there are 4 pupils with 1 brother or sister.

Use the diagram to answer these questions.

- How many pupils have 5 brothers and sisters?
- How many brothers and sisters do 5 pupils have?
- How many pupils are there in the group?
- How many pupils have less than 4 brothers and sisters?

2) The diagram below shows the marks obtained in a test by the pupils in group 9X.

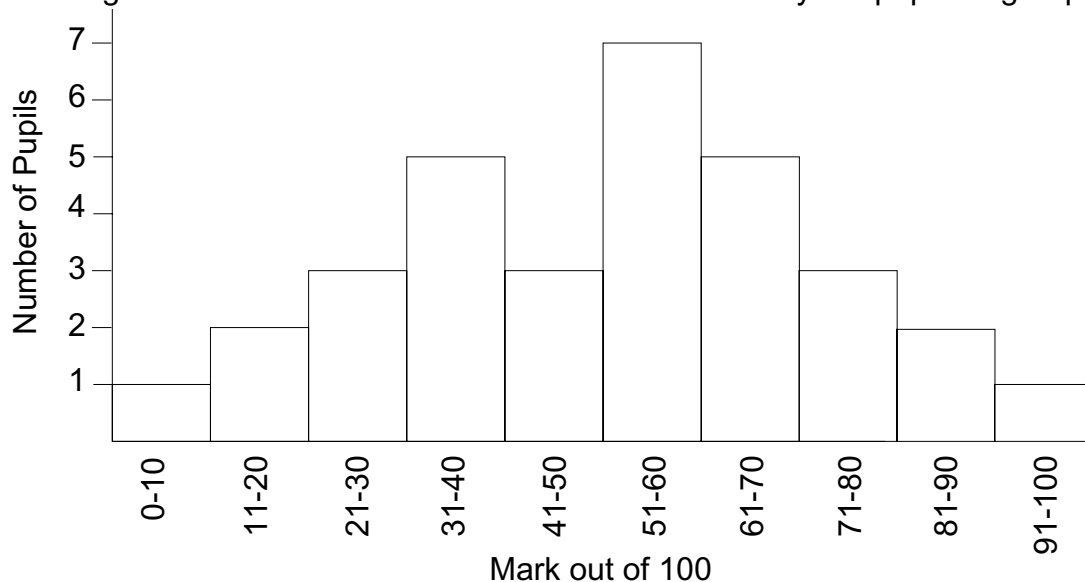

For example 3 pupils gained between 21 and 30 marks.

- How many pupils gained between 51 and 60 marks?
- How many pupils are in the group?
- How many pupils gained 51 or more?
- How many pupils gained less than 31?

Clothes Sizes

L.4

Anna works in a clothes shop. She sells 5 different sizes of mens jumper. The sizes are S (small), M (medium), L (large), XL (extra large) and XXL (extra extra large)

She records the jumpers she sells during the week.

	Size of Jumper sold
Monday	XL, L, S, M, L, S, M, M
Tuesday	S, L, M, XXL, M, M, XL, M, L
Wednesday	L, S, L, M, S, L, M, XL
Thursday	M, L, M, S, XL, L
Friday	S, M, L, XXL, S, L, M, M, XL, M
Saturday	L, M, M, S, XL, L, XXL, S, L, L, M, M, L, XXL
Sunday	M, M, L, L, S, L, L, XL, M, XL, M

- How many jumpers did she sell on Monday?
- On which day of the week did she sell the most jumpers?
- Copy this frequency table into your book. Use the data above to complete it.

Size	Tally	Frequency
S		
M		
L		
XL		
XXL		
	Total	

Use the table to answer these questions.

- How many jumpers of size XXL did Anna sell?
- Which size of jumper did Anna sell most of?
- Before she did the survey she thought that most of the sales would be size L or bigger. Was she right?

Book Prices

L.4

James works in a book shop. He works from 9:00am to 5:00pm. He keeps a record of the prices of the books he sells during the day.

This table shows his sales.

Time of day →	09:00 - 11:00	11:00 - 13:00	13:00 - 15:00	15:00 - 17:00
Price of book (£)	5	8	5	12
	9	4	10	3
	6	7	9	7
	7	6	6	7
	5	6	8	9
	11	3	7	10
	9	8	6	
	8	9		
	9	3		
		8		

The first book he sells costs £5. The second book costs £9.

- What is the price of the 6th book he sells?
- How many books does he sell between 9 o'clock and 11 o'clock?
- Between what hours does he sell the most books?

He now puts the data on this tally chart.

Price of Book	Tally	Frequency
Below £4		
£4 to below £7		
£7 to below £10		
£10 and above		
	Total	

- Copy the chart and complete it.
- How many books cost below £4?
- How many books cost between £4 and £7?
- James says that most books cost £7 or more. Is he right?
- How many books were sold altogether?

Mode and Range

L.4

1) The bar chart below shows the types of shoes sold in Joe's shop.

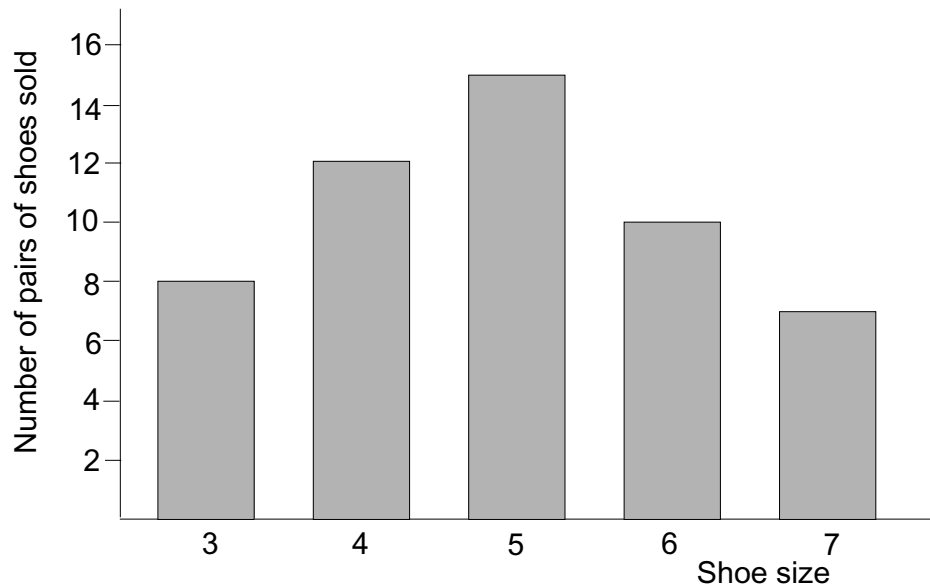

- What was the range of the shoe sizes sold?
- What was the mode of the shoe sizes sold?
- How many pairs of shoes were sold altogether?

2) The list below shows the ages of the people who go to the youth club.

13, 14, 16, 15, 15, 12, 13, 14, 15, 14, 14, 16, 15, 14, 13, 12, 16, 14, 13, 16,
14, 12, 16, 15, 14, 14, 14, 13, 12, 16, 16, 14, 15, 15, 12, 14, 13, 14, 15, 16,
13, 12, 15, 14, 14, 14

a) Draw this chart and use the tally method to find the frequency of each age.

Age	Tally	Frequency
12		
13		
14		
15		
16		

Use the chart to answer these questions.

- What is the range of the ages?
- What is the mode of the ages?
- How many people were at the youth club?

Describing Data

L.4

- 1) The height of the River Glegg is measured every day at noon.
The figures below indicate its height above normal for each day of October.
Each measurement is to the nearest metre.
1, 0, 1, 0, 0, 1, 1, 2, 1, 2, 2, 3, 3, 2, 3, 4, 3, 2, 3, 4, 4, 4, 3, 4, 3, 4, 3, 4, 3, 2, 3

Height	Tally	Frequency
0		
1		
2		
3		
4		

- a) Complete this frequency chart for the data.
b) What is the modal height of the river for October?
c) What is the range of the heights?
d) What part of the month was the wettest, the first half or the last half? Explain your answer.
- 2) a) Arrange these numbers into order of size, starting with the smallest.
8, 12, 9, 9, 11, 9, 8, 8, 11, 11, 10, 10, 8, 10, 9, 9, 8, 10, 11, 9
Look at your list of numbers and answer these questions.
b) What is the range of the numbers?
c) What is the mode of the numbers?
- 3) In Kidliston, 20 children go to the dancing class at the Village Hall.
The mode of their ages is 7 and the range of their ages is 4.
In Donnerton, 20 children go to the dancing class in the Village Hall.
The mode of their ages is also 7 but the range of their ages is 6.
Can you explain the difference between the ages of the two groups?
- 4) On a bag of Lindfold Toffees it says that it contains 20 sweets.
At the factory where they are made the bags are checked for the number inside.
They open 30 bags and count the sweets.
These are the results they get.
21, 20, 21, 20, 22, 21, 21, 20, 23, 20, 20, 21, 20, 20, 21, 22, 23, 20, 22,
22, 20, 21, 20, 21, 22, 20, 20, 23, 20, 20
a) Draw a tally chart of the data.
b) What is the modal number of sweets in a bag?
c) What is the range of the number of sweets in a bag?
d) Are they correct in saying that their bags contain 20 sweets? Explain your answer.

Rainfall Graph

L.4

Kwame checks the school weather station each day.

He has to measure the amount of rainfall.

These are the results he gets for one week in March.

Day	Mon.	Tues.	Wed.	Thurs.	Fri.	Sat.	Sun.
Rainfall in mm	1	6	7	4	2	0	3

He then puts this data onto a graph, like this.

Rainfall graph

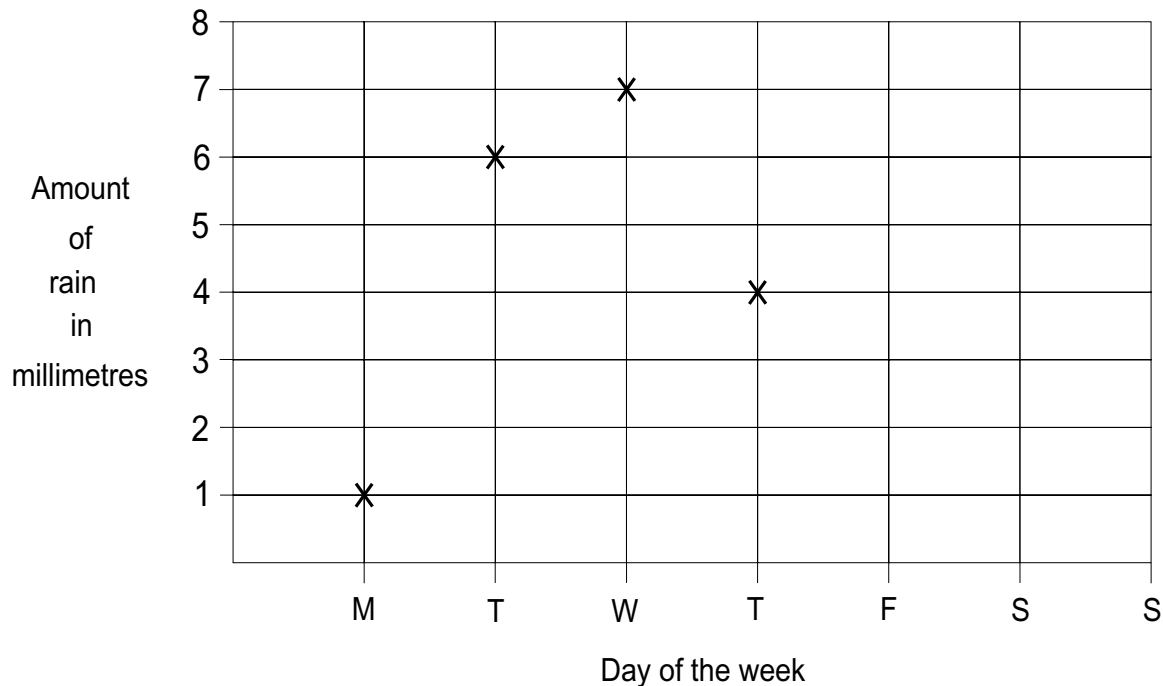

a) Finish off the graph.

Use the graph to answer these questions.

b) On which day was the rainfall 6mm?

c) What was the rainfall on Thursday?

d) On which day was there no rainfall?

e) What was the difference between the rainfall on Wednesday and Thursday?

f) What was the total amount of rainfall for the week?

g) The next week the total rainfall was 23mm. On Monday it was 11mm and on Tuesday it was 9mm. What can you say about the rest of the week?

Second-hand Cars

L.4

Mr. Williams wants to buy a car.

He can't afford a new one so he looks for an older one.

He visits some garages and takes note of the prices and the ages of the cars he wants.

He makes a graph of this information.

Prices of second-hand cars

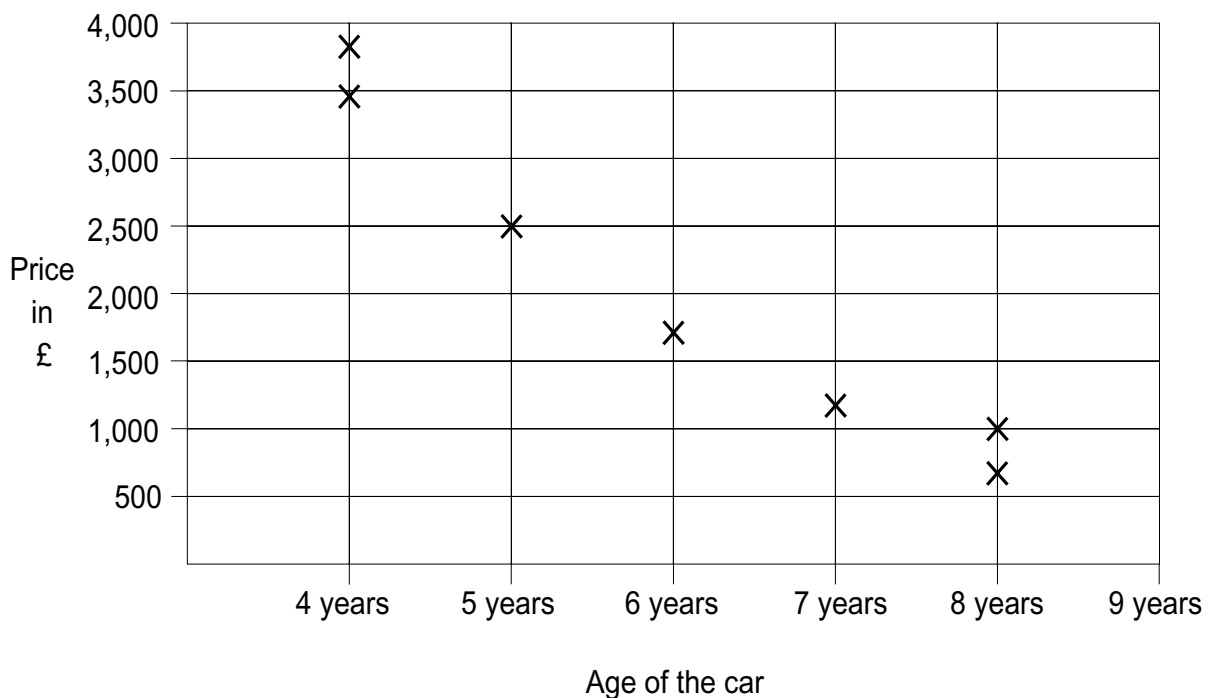

Use the graph to answer these questions

- How old was the car priced at £1,700?
- What was the approximate price of the 7 year old car?
- About how much would you expect to pay for a 9 year old car?
- Mr. Williams cannot afford to pay more than £3,000. How many cars can he choose from?
- Mrs. Williams looks at the graph. She says "The newer cars lose their value quicker than the older cars". Is she right? Explain your answer.
- Approximately what is the difference in price between an 8 year old and a 4 year old car?

Train Fares

L.4

This diagram shows the train fares between two towns.

The fare is different according to the time of day a journey is made.

It costs the most between 7:00 and 10:00 in the morning because this is when people want to get to work.

Train fares

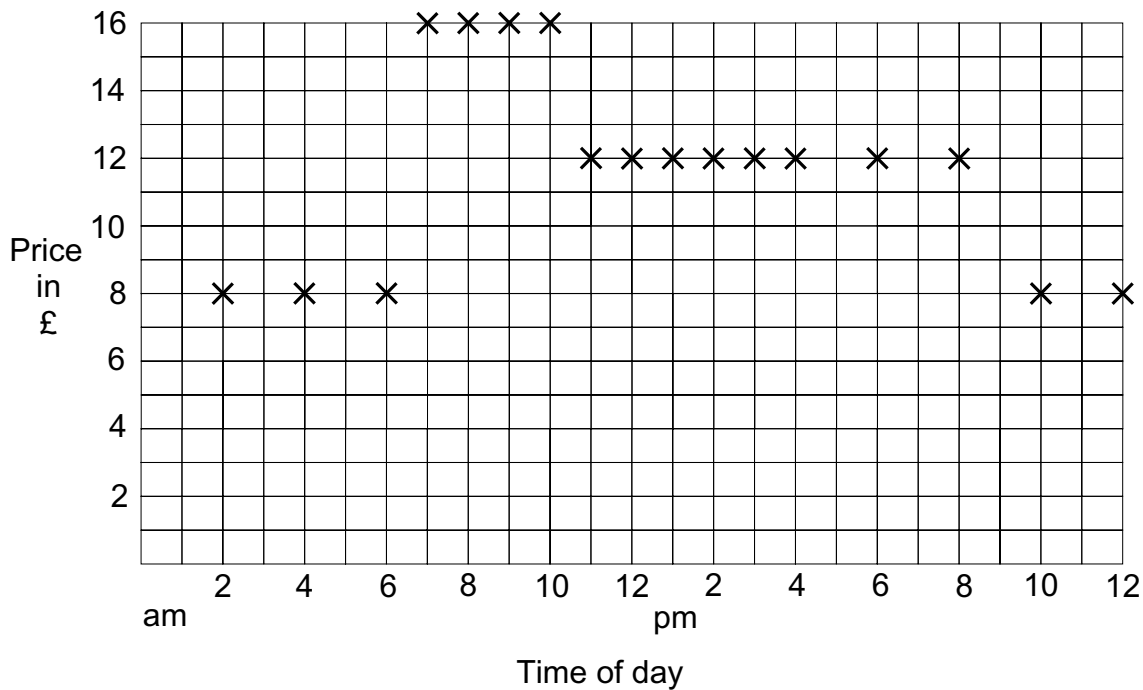

There are 17 journeys made each day.

All the departures are on the hour.

- At what time does the 7th train of the day leave?
- How many journeys are made between 11 am and 4 pm?
- What is the cost of the train fare between 11 am and 4 pm?
- The price of a child's fare is half an adult fare. What is a child's fare for a journey that leaves at 1:00 pm?
- Mrs. Gee and her two children catch the train at 7:00 am. What is the total cost of their tickets?
- If Mrs. Gee's train takes 1hr 24mins to get to its destination, at what time will it arrive?
- The train company put on an extra train. If it runs at 9:30 am, what is the cost of an adult's ticket?
- Between which two times is the price of a ticket £8?

Probability

L.4

1) Sandra has 3 bags each containing beads.

Bag 1 contains 4 white beads.

Bag 2 contains 1 white beads and 3 black beads.

Bag 3 contains 3 white beads and 3 Black beads.

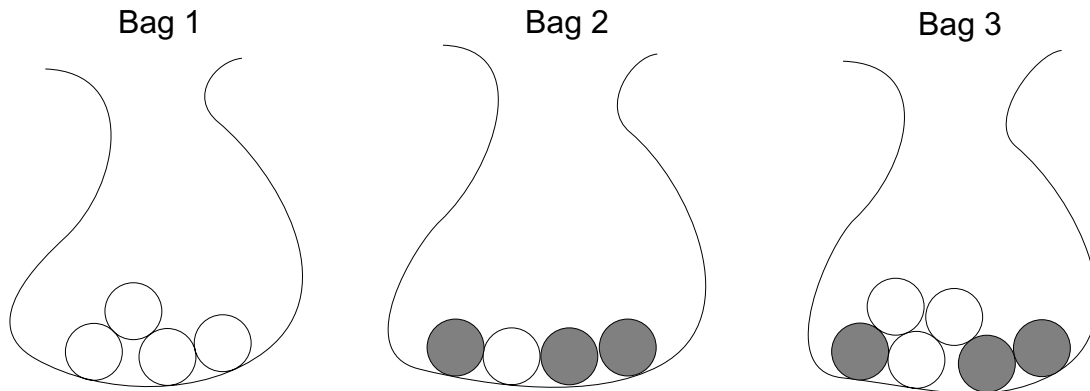

In the following questions, use one of these words to describe the probability.

Impossible, unlikely, equally likely, likely, certain.

Sandra puts her hand into a bag and without looking takes a bead from it.

- Sandra takes a white bead from bag 1
- Sandra takes a black bead from bag 1
- Sandra takes a black bead from bag 2
- Sandra takes a white bead from bag 2
- Sandra takes a black bead from bag 3

2) Khalid's class had to choose who was to be the register monitor for the week.

To be fair they wrote everyone's name on a separate piece of paper.

They put the pieces of paper in a bag and took one out.

There are 30 pupils in his class

Answer these questions.

- Khalid said that there was an equally likely chance they would choose a boy or a girl. If this was true, then how many boys were in the class?
- The next week a new pupil joined the class. He was a boy. Does this make it more likely or less likely that a boy's name is drawn from the bag?
- In the third week 6 girls and 9 boys go on a school trip. A name is selected from the remainder of the class. What name is more likely to be drawn, a boy's or a girl's?

Answers

Adding - Page 7

- 1) a) 60 b) 58 c) 75 d) 101 e) 77 f) 115 g) 161 h) 128
 i) 167 j) 148 k) 71 l) 125 m) 163 n) 81 o) 126 p) 71
 q) 119 r) 165
 2) a) 440 b) 499 c) 710 d) 370 e) 819 f) 238 g) 177 h) 779
 i) 909 j) 784 k) 708 l) 587 m) 807 n) 982 o) 570 p) 913
 q) 826 r) 803
 3) a) 396 b) 507 c) 609 d) 396 e) 704 f) 1269 g) 796
 h) 779 i) 1139 j) 1121 k) 361 l) 513 m) 811 n) 1363
 o) 847 p) 511

Subtracting - Page 8

- 1) a) 23 b) 33 c) 31 d) 32 e) 22 f) 3 g) 7 h) 7 i) 16 j) 38
 k) 26 l) 23 m) 31 n) 24 o) 30 p) 6 q) 28 r) 28 s) 66 t) 26
 u) 13 v) 15
 2) a) 122 b) 232 c) 133 d) 259 e) 410 f) 114 g) 217 h) 318
 i) 138 j) 136 k) 469 l) 674 m) 45 n) 68 o) 413 p) 431
 q) 551 r) 711 s) 649 t) 613 u) 236 v) 492 w) 337
 3) 84 4) 123 5) 17 6) 109 7) 81cm 8) 84

Negative Numbers - Page 9

- 1) a) Lunchtime b) 3 o'clock
 2) a) -10°C b) 30°C c) -10°C d) 5°C
 3) a) 24 feet b) 18 feet
 4) a) $-2:00$ b) $2:00$ c) $2:30$ d) $-0:30$

Fractional Parts - Page 10

- 1) a) $\frac{1}{4}$ b) $\frac{1}{2}$ c) $\frac{3}{4}$ 2) a) $\frac{1}{4}$ b) $\frac{3}{4}$ 3) a) $\frac{1}{10}$ b) $\frac{3}{10}$ c) $\frac{7}{10}$ d) $\frac{9}{10}$
 4) B $\frac{2}{5}$ C $\frac{3}{5}$ D $\frac{4}{5}$ 5) a) $\frac{1}{3}$ b) $\frac{1}{6}$ c) $\frac{1}{8}$ d) $\frac{1}{8}$ e) $\frac{1}{4}$ f) $\frac{2}{3}$
 g) $\frac{5}{6}$ h) $\frac{5}{8}$ i) $\frac{3}{8}$ j) $\frac{5}{12}$ k) $\frac{3}{5}$ l) $\frac{4}{7}$ m) $\frac{5}{6}$ n) $\frac{5}{9}$ o) $\frac{3}{8}$

Equivalent Fractions - Page 11

- 1) $\frac{6}{12}$, $\frac{3}{6}$, $\frac{4}{8}$, $\frac{8}{16}$, $\frac{2}{4}$ 2) $\frac{2}{6}$, $\frac{4}{12}$, $\frac{3}{9}$, $\frac{5}{15}$ 3) $\frac{6}{8}$, $\frac{12}{16}$, $\frac{9}{12}$

Approximation - Page 12

- 1) a) 6 units b) 6 units c) 6 tens or sixty d) 6 hundreds
 e) 6 tens or sixty f) 6 units.
 2) a) ten b) ten c) 1 unit d) 1 hundred e) 1 unit f) ten
 g) ten
 3) They are both correct but Helen is nearest, so Helen's approximation is better.
 4) Alice 5) a) 500 b) (ii) (iii) (v) c) examples (i) There are more than 450 people at the production (ii) There are about 490 people at the production (iii) There are between 450 and 500 people at the production 6) (i) (ii)

Number Chains - Page 13

- a) 12, 14 - add 2 on each time, or 2 times table
 b) 30, 35 - add 5 on each time, or 5 times table
 c) 11, 13 - add 2 on each time
 d) 15, 18 - add 3 on each time
 e) 17, 20 - add 3 on each time
 f) 26, 31 - add 5 on each time
 g) 32, 64 - double the last number
 h) 243, 729 - multiply the last number by 3
 i) 8, 13 - add together the last two numbers
 j) 16, 22 - the difference increases by 1
 k) -5 , -7 - subtract 2 each time

- l) -10 , -13 - subtract 3 each time
 m) 1, 3 - add 2 each time
 n) 2, 4 - add 2 each time
 o) -5 , -2 - add 3 each time
 p) -13 , -17 - subtract 4 each time
 q) $\frac{1}{4}$, $\frac{1}{8}$ - halve the last number

Money Problems - Page 14

- 1) a) £1.52 b) 48p 2) 5 with 15p over 3) a) £3.80 b) £6.80
 c) 60p 4) £63.16 5) £356.24 6) £2.05 7) 3 with £3.50 over
 8) 18 with 14p over 9) £2.29 10) a) £5.45 b) one £2, three £1's, two 20p's and one 5p

Rules - Page 15

- 1) a) 5, 6, 7, 8 b) 6, 7, 8, 10 c) 8, 9, 10, 11
 2) a) 7, 8, 9, 10 b) 11, 12, 14, 15 c) 16, 17, 18, 19
 3) a) 9, 11, 13, 15 b) 8, 10, 14, 16 c) 40, 42, 44, 46
 4) a) 10, 15, 20, 25, 30, 35 b) 10, 20, 30, 50, 60, 70 c) 7, 14, 21, 28, 35, 42





Triangular Dots - Page 16

- 1) a) 3 (although 1 is the smallest number in the series)
 b) no c) no d) yes
 2) 1, 3, 6, 10, 15, 21, 28, 36, 45, 55, 66, 78, 91
 3) a) no b) yes c) yes d) A number that is divisible by 3, or is a multiple of 3

Angles - Page 17

- 1) B, E, G, D, A, F, H, C 2) A, C, G, H are acute. D and E are right. B and F are obtuse 3) A - obtuse B - acute C - acute D - obtuse E - acute F - obtuse G - acute H, I, J and K are right

Turning - Page 18

- 1) (i)  (ii)  (iii)  (iv)  (v) 
 2) a) 1 4 3 2 1 4
 b) $\frac{1}{4}$ of a turn anticlockwise or $\frac{3}{4}$ of a turn clockwise
 c) 1 2 3 4 d) 3 4 1 2

Similar Shapes - Page 19

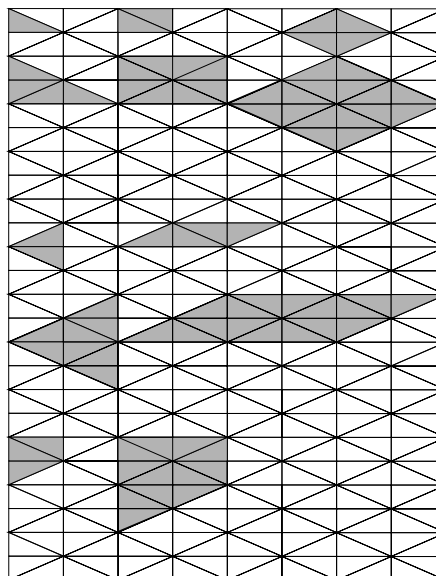

Fitting Shapes - Page 20

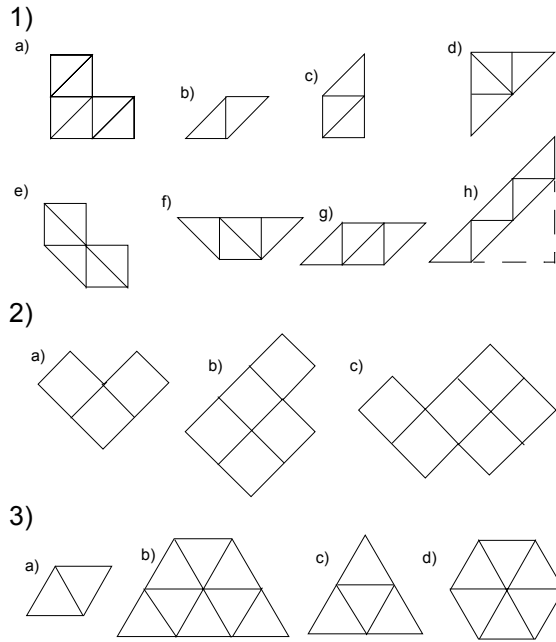

Reflection Symmetry - Page 21

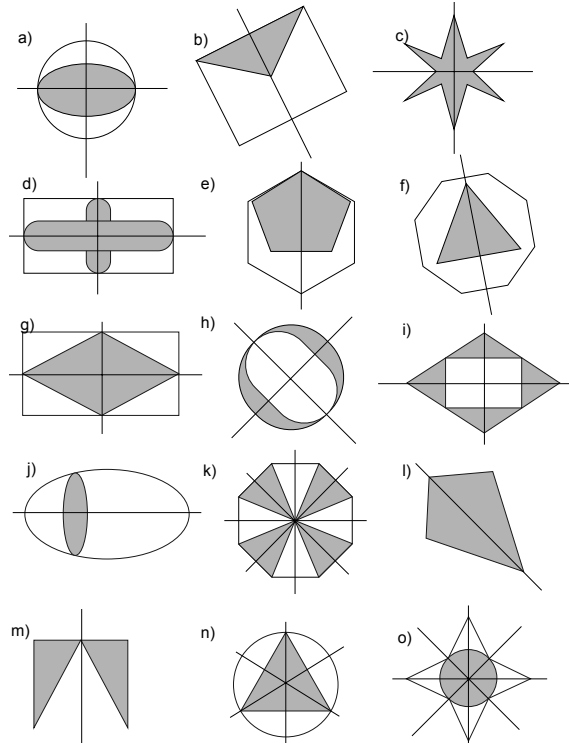

3 Dimensional Shapes - Page 22

- 1) a) Sphere b) Cylinder c) Cuboid d) Sphere e) Cuboid
f) Sphere g) Cone h) Cube i) Sphere j) Cube k) Cylinder
l) Cylinder
- 2) a) Cuboid and triangular prism b) Cuboid and cylinder
c) Cylinder and cone d) Cylinder and Sphere.

Measurements - Page 23

- Exercise 1
- 1) c) 2) a) 3) b) 4) a) 5) b) 6) d) 7) b) 8) a) 9) b)
10) b) 11) b) 12) c)

Exercise 2

- 1) 100cm and 1m 2) 6 litres and 6000ml 3) 7Kg and 7000g
4) 1km and 1000m 5) 1kg and 1000g 6) 300mm and 30cm
7) 2 litres and 2000ml

Exercise 3

- 1) metre 2) gram 3) litre 4) centimetre or millimetres
5) kilogram 6) millilitres

Reading Scales - Page 24

- a) 27 b) 380 c) 345 d) 35 e) 30 f) 49 g) 130 h) 100 i) 88

Time Intervals - Page 25

- a) 4 hours b) 3 hours c) 5 hours d) 6 hours e) 20 minutes
f) 25 minutes g) 50 minutes h) 25 minutes i) 50 minutes
j) 45 minutes k) 55 minutes l) 50 minutes

Paving Stones - Page 26

- 1) 24 2) 18 3) 60 4) 36 5) 40

Information - Page 27

- 1) a) 13 b) 17 c) 3 d) 6 2) a) £4.70 b) £7.20 c) £8.08
d) Individual answer e) Apple pie and custard.

Reading Tables - Page 28

- 1) a) 189 miles b) 66 miles c) 307 miles d) 92 miles
e) Leicester from London 2) a) £55 b) £31 c) £385 d) £217
e) £1421

Information Table - Page 29

- 1) a) 1 b) 23 c) 45 d) 181 e) Because they were not at
school 2) a) 11:05 b) 25 minutes c) 10:40 d) 22:35
e) 13 minutes f) 09:56

Calendar - Page 30

- a) Tuesday b) 30th April c) 28 d) 5 e) 4 f) January 23rd
g) 22th June h) 4th February i) 28 days j) Monday
k) Monday l) Sunday m) Tuesday n) 15 weeks

Using information - Page 31

- 1) a) 416 miles b) 320 miles c) Aberdeen and Plymouth
d) Liverpool and Birmingham e) 28 miles f) Aberdeen
2) a) 1 hour 45 minutes b) 45 minutes c) 11:20 d) 6:30

Pictograms - Page 32

- 1) a) 50 b) 35 c) 52 d)  2) a) 16 b) 11 c) 10
d) rabbit and horse e) 47

Barcharts - Page 33

- 1) a) 7 b) walking c) car d) 28 2) a) washing machine
b) 17 c) 26 d) 110

Charts and Pictograms - Page 34

- 1) a) cat b) any other pet
c)

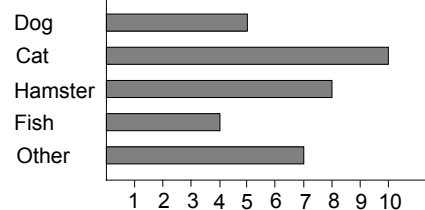

2)

- Cola
- Tea
- Coffee
- Squash
- Milk

3) a) 18 b)

- Apple
- Chocolate bar
- Orange
- Crisps
- Biscuits

Frequency Tables - Page 35

- 1) a) dog b) 38 c) cat d) some pupils had more than one pet
2) a) 4, 12, 6, 4, 3, 29 b) 29 c) walking d) car

Putting data into tables - Page 36

- 1) b) 7 c) 30 d) cold cereal 2) b) 5 c) 20

Adding Decimals - Page 37

- 1) a) 14.6 b) 382.98 c) 4.47 d) 39.8 e) 359.67 f) 58.58
g) 27.87 h) 13.06 i) 261.4 j) 4.14 k) 76.77 l) 973.63 m) 23.9
n) 297.7 o) 50.4 p) 59.3 q) 71.6 r) 530.91 s) 734.84
t) 245.84 u) 572.97 2) £25.33 3) £121.89 4) £8.69 5) £503
6) £13.51 7) 42.3cm 8) 66.94cm 9) 317.65kg

Subtracting Decimals - Page 38

- 1) a) 329.5 b) 213.41 c) 320.2 d) 239.41 e) 521.9 f) 300.95
g) 142.76 h) 131.16 i) 119.58 j) 565.57 k) 28.15 l) 279.03
m) 218.05 n) 594.14 o) 68.25 p) 523.2 q) 385.83 r) 77.74
2) £8.94 3) 74.2cm 4) 82.7kg 5) £16.21 6) 4.69 secs
7) 16cm 8) 22.65kg 9) 15.3cm 10) £154.19 11) £107.33

Multiplying - Page 39

- 1) a) 22 b) 39 c) 84 d) 135 e) 186 f) 294 g) 96 h) 135
i) 150 j) 301 k) 108 l) 372 m) 385 n) 190 o) 270 p) 242
q) 920 r) 710 s) 1771 t) 2418 u) 302 v) 924 w) 1281
x) 2008 y) 3618 z) 4509 2) 120 3) 138 4) 80 tonnes 5) 208
6) 108 7) 207 8) 156 9) 96 10) £5944

Dividing - Page 40

- 1) a) 10 b) 11 c) 12 d) 12 e) 13 f) 16 g) 22 h) 19 i) 37
j) 29 k) 17 l) 12 m) 26 n) 22 o) 11 p) 12 q) 16 r) 12 s) 18
t) 17 2) a) 15 r 1 b) 11 r 1 c) 13 r 2 d) 18 r 3 e) 15 r 1
f) 16 r 4 g) 12 r 4 h) 14 r 1 i) 13 r 3 j) 41 r 1 k) 21 r 5
l) 30 r 5 m) 26 r 5 n) 27 r 7 o) 21 r 1
3) a) 62 b) 60 c) 31 d) 36 r 7 e) 36 r 8 f) 422 g) 88 r 1
h) 67 i) 33 r 4 j) 72 r 4 k) 61 r 5 l) 179 m) 77 r 4 n) 109
o) 111 r 4
4) 36 5) 18 6) a) 23 trays with 1 left over. b) 5 7) 212 8) 13
9) 38 weeks 10) 15 11) 150 12) 33 eggs with 2p left over

Writing Fractions - Page 41

- 1) $\frac{2}{9}$ b) $\frac{2}{15}$ c) $\frac{4}{21}$ d) $\frac{1}{15}$ e) $\frac{5}{9}$ f) $\frac{7}{15}$ g) $\frac{10}{21}$ h) $\frac{8}{15}$
2) A $\frac{1}{6}$ B $\frac{1}{3}$ C $\frac{3}{4}$ 3)

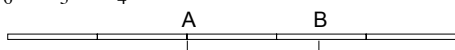

4) a) correct b) incorrect c) correct d) incorrect.

- 5) all answers are approximate a) $\frac{3}{4}$ b) $\frac{1}{3}$ c) $\frac{1}{10}$ 6) a) $\frac{1}{3}$
b) $\frac{1}{2}$ c) $\frac{3}{4}$ d) $\frac{1}{5}$ e) $\frac{1}{3}$ f) $\frac{1}{2}$ g) $\frac{3}{4}$ h) $\frac{1}{3}$ or $\frac{1}{4}$ i) $\frac{3}{8}$ j) $\frac{1}{2}$

Percentages - Page 42

- 1) a) Approximately A 15% B 35% C 60% D 70% E 90%
2) a) 50% b) 60% c) 20% d) 35% e) 35%
3) a) 25% b) 70% c) 40% d) 60%
4) 45% 5) a) 25% b) 75% 6) 50% 7) 25%

Mixing - Page 43

- 1) a) 125g, 125g, 200g, 1 egg, 150ml
b) 500g, 500g, 800g, 4 eggs, 600ml
c) 375g, 375g, 600g, 3 eggs, 450ml
2) a) 30g, 125g, 60g, $\frac{1}{2}$ egg, 75ml

b) 90g, 375g, 180g, $1\frac{1}{2}$ eggs, 225ml

c) 150g, 625g, 300g, $2\frac{1}{2}$ eggs, 375ml

3) a) Tandi b) Sara c) no. Bryn's mixture has the same amount of red and yellow. Sara and Tandi's mixture has the same amount of red and yellow. So both mixtures will be the same shade.

4) a) Maria. Ben's has a bigger proportion of water in it than Maria's so it will be weaker.

b) Faster, because they will have to use more squash each time. c) 160ml

Multiplication Tables - Page 44

234, 273, 312, 351, 390

258, 301, 344, 387, 430

- a) 117 b) 172 c) 195 d) 215 e) 8 f) 9 g) 39 h) 39 i) 43
j) 43 k) 390 l) 430 m) 780 n) 1290 o) 663 p) 688

Combining Multiplication Tables - Page 45

- 1) a) 54, 63, 72, 81, 90
48, 56, 64, 72, 80
85, 102, 119, 136, 153, 170
b) 136, 128, 144
2) a) 42, 49, 56, 63, 70
168, 196, 224, 252, 280
b) 224, 280, 336

Missing Numbers - Page 46

- 1) a) 5 b) 22 c) 22 2) a) 23 b) 23 c) 15 3) a) 34 b) 45
c) 34 4) a) 16 b) 16 c) 160 5) a) 12 b) 12 c) 35
6) A quarter of 32, $5 + 3$, $16 \div 2$, 4×2 , four times 2, half of 16, twice 4, $17 - 9$ 7) a) \div b) $+$ c) \times d) \div e) \div f) \times g) $-$
h) $+$ i) $+$ j) \div k) \times l) $-$ 8) a) 13 b) 5 c) 100 d) 10 e) 6
f) 8 g) 10 h) 12 i) 4 j) 8 k) 18 l) 6

Number Lines - Page 47

- a) 0.7, 0.9, 1.0 b) 2.3, 3.0 c) 7.2, 7.9, 8.3 d) 15.8, 16.2, 16.7
e) 34.2, 34.5, 34.9 f) 2.15, 2.19 g) 0.38, 0.41, 0.45
h) 3.08, 3.14, 3.20 i) 6.98, 7.03, 7.07 j) 22.03, 22.07, 22.13

Putting Numbers in Order - Page 48

Exercise 1

- a) 3, 14, 16, 23, 128 b) 2, 74, 93, 357, 832
c) 0.2, 3.6, 6.7, 7.4, 19.2 d) 0.7, 4.1, 8.4, 9.0, 18.5
e) 3, 8.3, 14.5, 17, 27 f) 0.5, 4.5, 17, 73, 81
g) 0.7, 6.3, 7.5, 9.5, 29 h) 5.7, 8, 9.2, 18.7, 33.3

- i) 2, 6.3, 7.4, 71, 84.5 j) 0.4, 5.3, 9.1, 9.4, 72.6

Exercise 2

- a) 1.43, 3.56, 4.85, 7.31, 7.43
 b) 1.63, 5.28, 7.54, 8.34, 9.64
 c) 6.45, 7.42, 8.0, 8.43, 8.45
 d) 3.65, 6, 7.6, 8.52, 9.46
 e) 4.5, 6.0, 8.34, 12, 27.5
 f) 4.87, 8.45, 9.53, 9.7, 81.6
 g) 5.67, 9.63, 36.7, 74.0, 123
 h) 0.3, 3.9, 7.65, 34.85, 71.5
 i) 8.65, 9.76, 16, 81, 95.65
 j) 0.38, 5.81, 8.56, 9.75, 13.29

Exercise 3

- a) 2.856, 3.651, 7.405, 8.297, 9.356
 b) 9.765, 9.769, 23.654, 34.654, 64.836
 c) 5, 5.463, 6, 6.243, 8.593
 d) 4.7, 6.386, 8.493, 9.460, 12.53
 e) 3.505, 3.6, 5.986, 7.65, 9
 f) 0.138, 6.392, 7.8, 9.001, 9.432
 g) 0.8436, 2.7406, 6.904, 7.86, 8.651
 h) 3.765, 5.37, 9, 9.036, 786
 i) 9.014, 9.054, 76.65, 83.76, 786.8
 j) 0.98, 3.56, 7, 8.35, 76.65
 k) 0.001, 3.56, 3.765, 65.98, 87.829

Magic Squares - Page 49

a)

14	9	16
15	13	11
10	17	12

b)

13	18	11
12	14	16
17	10	15

c)

4	3	8
9	5	1
2	7	6

d)

13	8	15
14	12	10
9	16	11

e)

13	8	9
6	10	14
11	12	7

f)

9	4	5
2	6	10
7	8	3

g)

14	19	12
13	15	17
18	11	16

h)

7	2	3
0	4	8
5	6	1

i)

11	6	7
4	8	12
9	10	5

j)

10	11	6
5	9	13
12	7	8

k)

14	9	10
7	11	15
12	13	8

l)

6	5	10
11	7	3
4	9	8

Making Numbers - Page 50

- a) 23 b) 9532 c) 9509 d) There are 3 odd digits to go on the ends of numbers, whereas there is only one even digit to go on the ends e) 2 and 5 f) 5, 2 and 9 g) 3 and 9 h) any 4 card numbers ending with 5 i) 9×3 or 3×9 j) $5 - 3$ k) 9 and 3 l) 9 and 2 m) $3 + 2 + 5$ n) $5 - 3 - 2$ or $3 + 2 - 5$ or $2 + 3 - 5$ o) $3 \times 2 + 9$ p) $5 \times 3 - 9$ q) $5 + 3 + 2 + 9$ r) $5 + 3 + 2 - 9$ s) $9 + 5 - 3 - 2$ or $9 + 3 + 2 - 5$

Comparing - Page 51

- 1) a) $3 < 6$ b) $6 < 8$ c) $7 > 4$ d) $3 < 9$ e) $12 < 24$ f) $-3 < 7$
 g) $-6 < 0$ h) $2 > -5$ i) $1 > -7$ j) $-3 < -2$ k) $-6 < -1$ l) $0 > -5$
 m) $-3 < 0$ n) $2 + 2 = 5 - 1$ o) $6 - 7 < 1$ p) $9 - 3 > -6$
 q) $3 - 6 < -3 + 3$ r) $7 - 4 = 4 - 1$ s) $11 + 2 = 5 + 8$
 t) $15 - 5 = 5 + 5$ u) $14 + 3 > 22 - 6$ v) $20 - 22 < 22 - 20$
 w) $13 + 14 = 14 + 13$ x) $12 - 3 > -12 + 3$
 2) a) - b) + c) + d) + e) ++ f) -+ g) - h) + i) + j) +- k) +- l) -+ m) - n) - o) - p) + q) - r) - s) -+ t) -- u) +- v) +- w) - x) - y) -- z) +

Chain Rules - Page 52

- 1) a) $\frac{1}{32}, \frac{1}{64}$ - each number is halved to get the next
 b) $6, 4\frac{1}{2}$ - subtract $1\frac{1}{2}$ from the last number
 c) $\frac{3}{32}, \frac{3}{64}$ - each number is halved to get the next
 2) a) 9, 12, 15 - add 3 to the last number
 12, 24, 48 - double the last number
 b) 3, 4, 5 - add 1 to the last number
 4, 8, 16 - double the last number
 c) 5, 7, 9 - add 2 to the last number
 9, 27, 81 - multiply the last number by 3
 d) 0, -10, -20 - subtract 10 from the last number
 $5, 2\frac{1}{2}, 1\frac{1}{4}$ - halve the last number
 e) 0, -4, -8 - subtract 4 from the last number
 2, 1, $\frac{1}{2}$ - halve the last number
 f) -3, -9, -15 - subtract 6
 $1, \frac{1}{3}, \frac{1}{9}$ - divide by 3
 g) -3, -4, -5 - subtract 1
 -4, -8, -16 - double
 h) 0, 4, 8 - add 4
 -2, -1, $-\frac{1}{2}$ - halve
 i) -15, -21, -27 - subtract 6
 -27, -81, -243 - multiply by 3
 j) 0, -1, -2 - subtract 1
 $\frac{1}{2}, \frac{1}{4}, \frac{1}{8}$ - halve

Mental Arithmetic - Page 53

- 1) a) $20 + 40 + 7 + 2$ b) $40 + 50 + 3 + 6$
 2) a) $16 + 7 = 23$ b) $53 + 4 = 57$
 $23 + 30 = 53$ $57 + 40 = 97$
 3) a) $80 - 30 = 50$ b) $90 - 60 = 30$
 $9 - 6 = 3$ $7 - 3 = 4$
 so $89 - 36 = 53$ so $97 - 63 = 34$
 4) a) 27 to 30 is 3 b) 48 to 50 is 2
 30 to 50 is 20 50 to 90 is 40
 50 to 51 is 1 90 to 93 is 3
 so $51 - 27 = 24$ so $93 - 48 = 45$
 5) a) 19 to 20 is 1 b) 25 to 30 is 5
 20 to 40 is 20 30 to 70 is 40
 40 to 44 is 4 70 to 73 is 3
 so $44 - 19 = 25$ so $73 - 25 = 48$
 c) 24 to 30 is 6 d) 21 to 30 is 9
 30 to 40 is 10 30 to 50 is 20
 40 to 48 is 8 50 to 53 is 3
 so $48 - 24 = 24$ so $53 - 21 = 32$
 e) 26 to 30 is 4 f) 29 to 30 is 1
 30 to 80 is 50 30 to 40 is 10
 80 to 87 is 7 40 to 43 is 3
 so $87 - 26 = 61$ so $43 - 29 = 14$
 g) 37 to 40 is 3 h) 39 to 40 is 1
 40 to 70 is 30 40 to 60 is 20
 70 to 76 is 6 60 to 67 is 7
 so $76 - 37 = 39$ so $67 - 39 = 28$

Tests for Dividing - Page 54

- 1) a) 4, 14, 20, 26, 34 b) 5, 10, 15, 25, 40, 50
 c) 10, 20, 40, 50, 60, 80, 90
 2) a) $7 + 3 = 10$ b) $6 + 8 = 14$ c) $7 + 2 = 9$
 $1 + 0 = 1$ $1 + 4 = 5$ yes
 no, 3 will not no
 divide exactly

- d) $9 + 4 = 13$
 $1 + 3 = 4$
 no
- 3) a) $5 + 6 = 11$
 $1 + 1 = 2$
 no
- d) $2 + 5 + 7 = 14$
 $1 + 4 = 5$
 no
- e) $8 + 1 = 9$
 yes
- b) $1 + 0 + 8 = 9$
 yes
- e) $4 + 9 + 1 = 14$
 $1 + 4 = 5$
 no
- c) $1 + 2 + 7 = 10$
 $1 + 0 = 1$
 no

Tens, Hundreds and Whole Nos. - Page 55

- 1) a) 20 b) 7 rows and 3 stamps c) 620 2) 17
 3) a) 50, 110, 130, 900, 1200, 3,560 b) 9, 3, 4, 6, 3, 2, 8, 1, 2, 0, 8 c) 300, 1000, 1200 d) 21, 72, 36, 22, 26, 21, 62, 62, 51, 42 4) a) 35 miles b) 245 miles

Tens, Hundreds and Decimals - Page 56

- 1) 14cm 2) a) 600cm or 6 metres b) 12 metres c) 15 metres
 3) a) £1.60 b) £16.00 c) £41.60 4) a) 2.7cm b) 3.8cm
 c) 5.2cm d) 8.5cm e) 12.4cm f) 25.6cm g) 59.4cm
 5) a) 1.28cm b) 3.41cm c) 5.62cm d) 4.81cm e) 7.56cm
 f) 9.41cm g) 54.26cm 6) 58.5 miles 7) a) £131 b) £786
 c) £13.10 d) £812.20 8) a) £615 b) £1165.60 c) £3526.20
 9) a) £3.80 b) $£3.80 \div 4 = £0.95$

Position - Page 57

- 1) (3,3), (3,10), (9,10), (9,14), (4,14), (4,17), (13,17), (13,12), (18,12), (18,8), (14,8), (14,3)
 2)b)

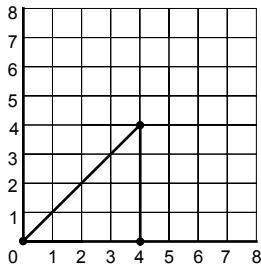

- c) 3 d) (0,0), (6,0)

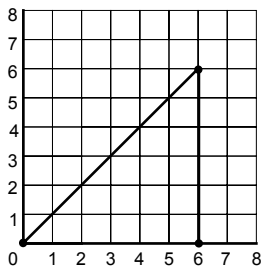

Co-ordinates - Page 58

- 1) a) b) c) H

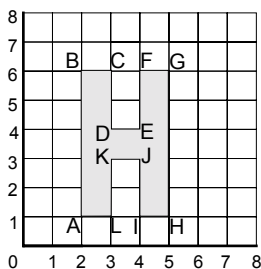

- 2) (5,2) 3) (0,4) and (6,4) 4)

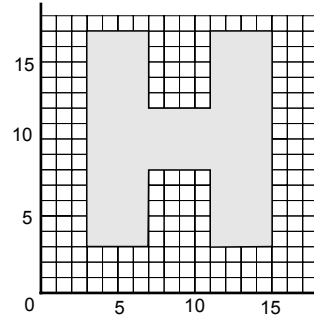

- (11,17), (15,17), (15,3), (11,3), (11,8), (7,8)
 5)

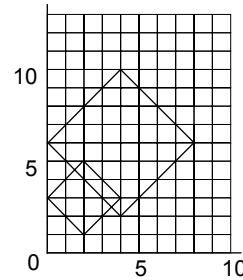

- Four small squares will fit into the larger one
 6)

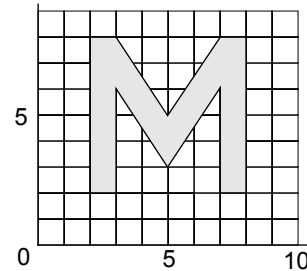

- (7,8), (8,8), (8,2), (7,2), (7,6)

Number Patterns - Page 59

- 1) a) 3 b) 12 c) 30 d) multiply the pattern number by 3
 2) a) 25 b) 100 c) multiply the pattern number by itself
 3) a) 2 b) 10 c) 22 d) multiply pattern number by 2 and add 2

Number Machines - Page 60

- 1) a) £65, £80, £95 b) (i) £155 (ii) £230 (iii) £305
 2) a) 15 b) 42 c) 60 3) a) 9 b) 19 c) 33 4) a) 12 b) 16 c) 20

Angles Between - Page 61

- 1) a) 180° b) 90° c) 45° d) 45° e) 45° f) 135° g) 180°
 2) a) 90° b) 30° c) 60° d) 30° e) 120° f) 150° g) 90° h) 210°
 i) half an hour

Turning Patterns - Page 62

- 1) a) 2, 4, 1, 3, 5 b) 1, 4, 2, 5, 3, 1, 4 c) $\frac{4}{5}$ turn clockwise
 or $\frac{1}{5}$ turn anticlockwise 2) a) 4, 3, 2, 1, 6, 5 b) 1, 5, 3, 1, 5
 c) $\frac{1}{2}$ turn clockwise 3) a) 2,5,8,3,6,1,4,7 b) 1,6,3,8,5,2,7,4,1,
 6,3 c) $\frac{7}{8}$ turn clockwise or $\frac{1}{8}$ turn anticlockwise

Reflections - Page 63

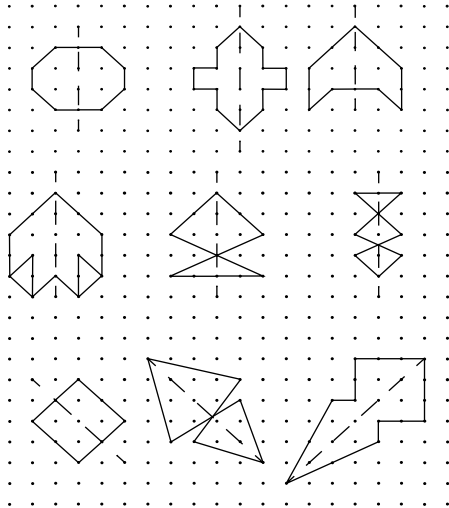

Rotation - Page 64

1)

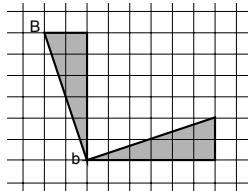

2)

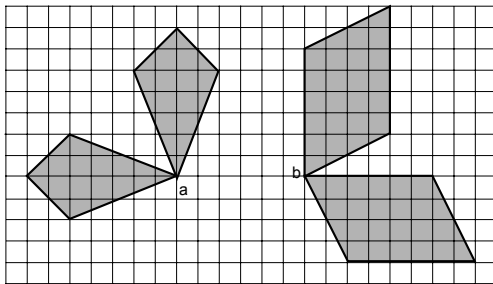

3)

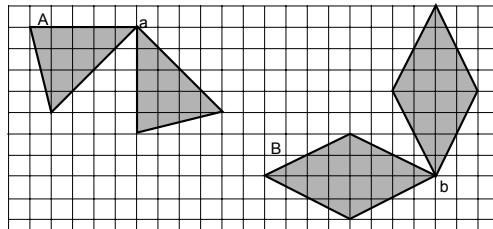

Volume of a Cuboid - Page 65

a) 12 b) 24 c) 24 d) 48 e) 32 f) 48 g) 48 h) 60

Volume of a Shape - Page 66

a) 10 b) 18 c) 32 d) 48 e) 40 f) 44 g) 80

Packing Boxes - Page 67

1) a) 30 b) 210 2) 125 3) 168 4) 192

Area and Perimeter - Page 68

1) a) (i) 30 square centimetres (ii) 22 centimetres
 b) (i) 48sq cm (ii) 28cm c) (i) 70sq cm (ii) 34cm
 d) (i) 96sq cm (ii) 40cm 2) a) 10 b) 11 c) between 45 and 50

Measuring Lines - Page 69

a) 5.4 b) 65.5 c) 2.6 d) 3.5 e) 5.2 f) 1.7 g) 1.7 h) 13.5 i) 6.5

Measuring Instruments - Page 70

1) a) $\frac{1}{2}$ litre b) $1\frac{1}{4}$ litres c) 1700ml d) 750ml e) $1\frac{1}{2}$ pints
 f) $3\frac{1}{2}$ pints
 2) Helen 47kg Mrs. Jones 60kg Mr. Jones 95kg
 Laura 36kg
 3) a) 1.75kg b) 5.4kg

Measuring Lengths - Page 71

1) Anna 1.26m (126cm) Michael 1.3m (130cm)
 Gareth 1.39m (139cm) Sian 1.46 (146cm)
 2) 13.5cm (135mm) 11.7cm (117mm) 8.9cm (89mm)
 3) 10.4cm 6.8cm

Adding Time - Page 72

1) a) 11:10 b) 25 c) 7:20 d) 0:55 e) 20 f) 19:00 g) 30
 h) 17:38 i) 11:27 j) 2 hours 24 minutes k) 5:07
 l) 1 hour 27 minutes m) 10:07 n) 11:03

Making Areas - Page 73

1) a) 12 b) (i) 59 (ii) £79
 2) a) 12 of 60cm, 24 of 45cm, 18 of 30cm b) £86.40

Years - Page 74

1) 1940 2) 1936 3) 60 and 63 4) a) 2007 b) 22 June 1993
 5) a) 1945 b) 2020 6) 2016 7) a) 1968 b) 2020
 8) November 1992 9) a) 15 b) 16 10) 20th January 2001
 11) (i) h (ii) j (iii) o (iv) a (v) c (vi) e

Bars - 75

1) a) 3 b) 4 c) 29 d) 20 2) a) 7 b) 32 c) 18 d) 6

Clothes Sizes - Page 76

a) 8 b) Saturday c)

Size	Tally	Frequency
S	###-##	11
M	###-##-###-###-	23
L	###-##-##-##	20
XL	###	8
XXL		4
Total		66

d) 4 e) M f) no

Book Prices - Page 77

a) £11 b) 9 c) 11:00 - 13:00 d)

Price of Book	Tally	Frequency
Below £4		3
£4 to below £7	###	9
£7 to below £10	###-##-##-##-	16
£10 and above		4
Total		32

e) 3 f) 9 g) yes h) 32

Mode and Range - Page 78

1) a) 4 b) 5 c) 52 2) a)

Age	Tally	Frequency
12	### /	6
13	### //	7
14	### ### ### /	16
15	### ///	9
16	### //	8
Total		46

b) 4 years c) 14 d) 46

Describing Data - Page 79

1)a)

Height	Tally	Frequency
0	///	3
1	###	5
2	### /	6
3	### ###	10
4	### //	7
Total		31

b) 3 metres c) 4 metres d) the last half: for example most of the 0's and 1's occur in the first half and most of the 3's and 4's in the last half.

2) a) 8, 8, 8, 8, 8, 9, 9, 9, 9, 9, 10, 10, 10, 10, 11, 11, 11, 11, 12 b) 4 c) 9

3) At Kidliston the ages are closer together. The difference between the oldest and youngest is 4 years.

At Donnerton the ages are more spread out. The difference between the oldest and the youngest is 6 years.

4) a)

Number in bag	Tally	Frequency
20	### ### ///	14
21	### ///	8
22	###	5
23	///	3
Total		30

b) 20 c) 3 d) yes, although some contain extra sweets

Rainfall Graph - Page 80

a)

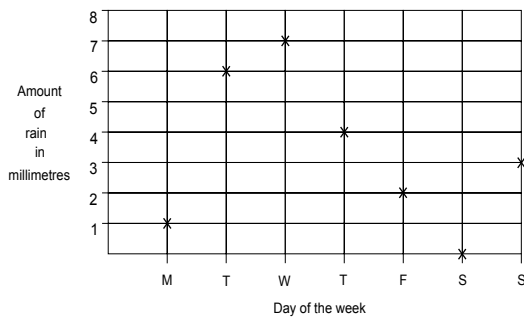

b) Tuesday c) 4mm d) Saturday e) 3mm f) 23mm g) A total of only 3mm of rain fell in the next 5 days so it was dry compared with the beginning of the week

Second-hand Cars - Page 81

a) 6 years b) £1200 c) £500 d) 5 e) yes The drop from 4 years to 5 years is approximately £1100. The drop from 5 to 6 is approx. £800. The drop from 6 to 7 is approx. £500. The drop from 7 to 8 is approx. £300 f) £2,800

Train Fares - Page 82

a) 10 am b) 6 c) £12 d) £6 e) £32 f) 8:24 g) £16 h) 10:00 pm and 6:00 am

Probability - Page 83

1) a) certain b) impossible c) likely d) unlikely e) equally likely 2) a) 15 b) more c) girl's

