

GCSE Mathematics
2019 Predicted Paper 2h (Calculator)
1MA1
Higher Tier (1hr 50mins)

Remember: *This paper is targeting grade 6/7+, so please be prepared for some challenges.* These questions are just a guide. There are no guarantees that these questions/topics will come up! So, revise all you can before the calculator exams!

Instructions

- Use **black** ink or ball-point pen.
- Answer **all** questions.
- Answer the questions in the spaces provided
– *there may be more space than you need*
- You must show all your working
- **Calculators may be used**
- Diagrams are **NOT** accurately drawn, unless otherwise indicated

Information

- The total mark for this paper is **100**.
- The marks for **each** question are shown in brackets
– *use this as a guide as to how much time to spend on each question.*

Advice

- Read each question carefully before you start to answer it.
- Keep an eye on time.
- Try to answer every question.
- Check your answers if you have time at the end.

Answer ALL questions.

Write your answers in the spaces provided.

You must write down all the stages in your working.

1. The value of a van depreciates at the rate of 20% per year.
Gary buys a new van for £27 500
After n years the value of the van is £11 264
Find the value of n .

.....(2)

2. The diagram shows two vertical posts, AB and CD , on horizontal ground.

$AB = 1.7$ m

The angle of elevation of C from

Calculate the length of BD .

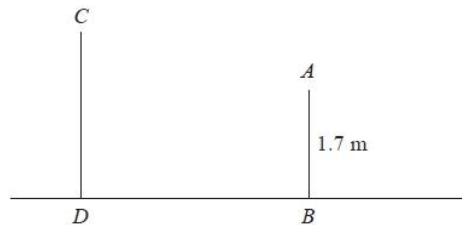

$CD : AB = 1.5 : 1$

A is 52°

Give your answer correct to 3 significant figures.

.....(4)

3. Here are two pots.

Pot **A** and pot **B** are similar.

The area of the base of pot **B** is

Work out the area of the base of pot **A**.

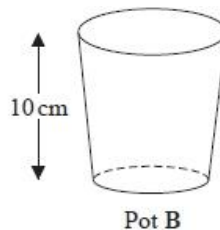
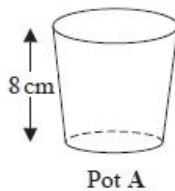

mathematically

160 cm².

.....(2)

4. A frustum is made by removing a small cone from a large cone as shown in the diagram.

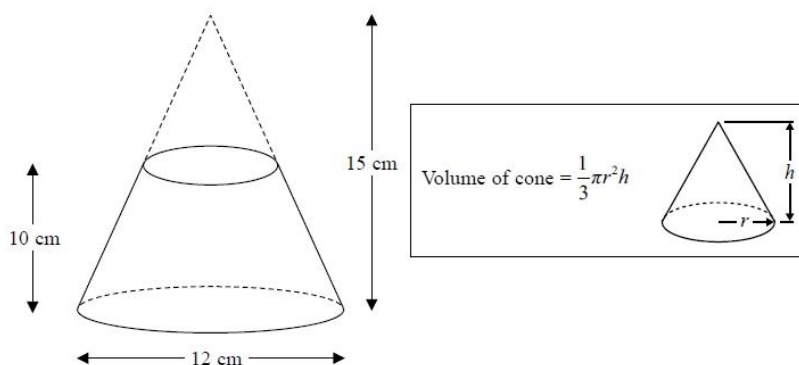

The frustum is made from glass. The glass has a density of 2.5 g / cm³

Work out the mass of the frustum.

.....(5)

5. The diagram shows a quadrilateral *JKLM*.

Work out the size of angle KLM .
 answer correct to 3 significant

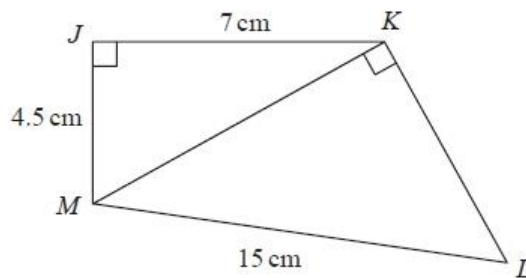

Give your
 figures.

.....(4)

6. The area of triangle ABC is 42 cm^2
 Find the length of AB .

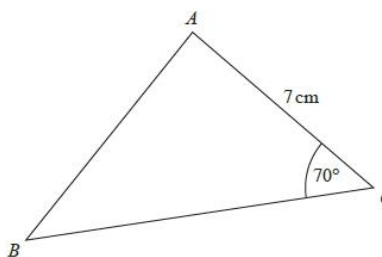

Give your answer correct to 3 significant figures.

.....(5)

7. On a school trip the ratio of the number of teachers to the number of students is $1 : 15$
 The ratio of the number of male students to the number of female students is $7 : 5$
 Work out what percentage of all the people on the trip are female students.
 Give your answer correct to the nearest whole number.

.....(3)

8. (a) Show that the equation $x^3 + 5x - 4 = 0$ has a solution between $x = 0$ and $x = 1$

.....(2)

(b) Show that the equation $x^3 + 5x - 4 = 0$ can be arranged to give $x = \frac{4}{x^2 + 5}$

.....(2)

(c) Starting with $x_0 = 0$, use the iteration formula $x_{n+1} = \frac{4}{x_n^2 + 5}$ twice, to find an estimate for the solution of $x^3 + 5x - 4 = 0$

.....(3)

9. Asha and Lucy are selling pencils in a school shop. They sell boxes of pencils and single pencils.

Asha sells 7 boxes of pencils and 22 single pencils.

Lucy sells 5 boxes of pencils and 2 single pencils.

Asha sells twice as many pencils as Lucy.

Work out how many pencils there are in a box.

.....(4)

10. Here is the graph of $y = x^2 - 2x - 4$

(a) Write down estimates for the roots of $x^2 - 2x - 4 = 0$

.....(2)

(b) Write down the coordinates of the turning point of $y = x^2 - 2x - 4$

..... (1)

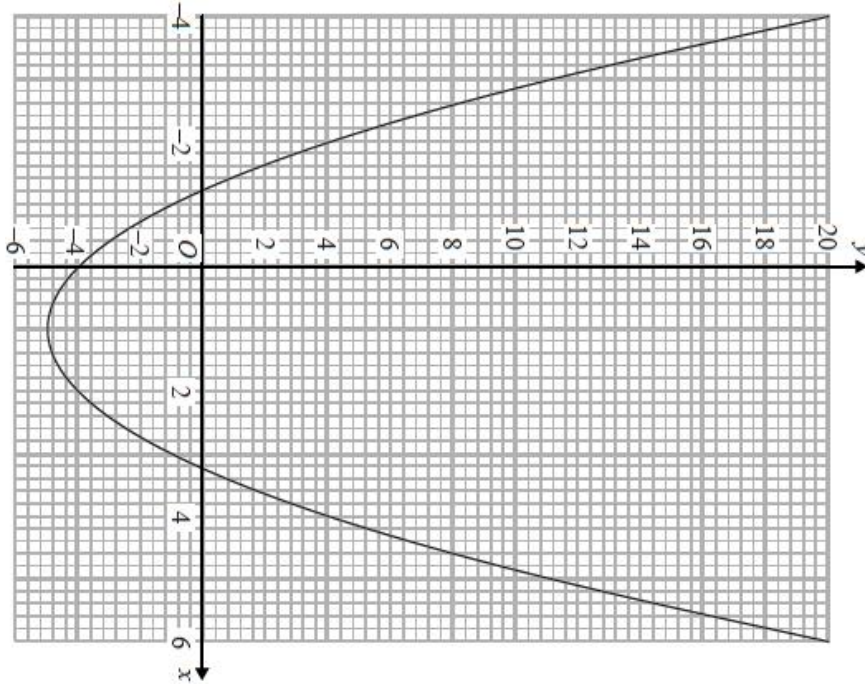

11. On the grid below show, by shading, the region defined by the inequalities

$$y \geq -1 \quad y \leq 4 - x \quad y \leq 3x - 1$$

Mark this region with the letter R.

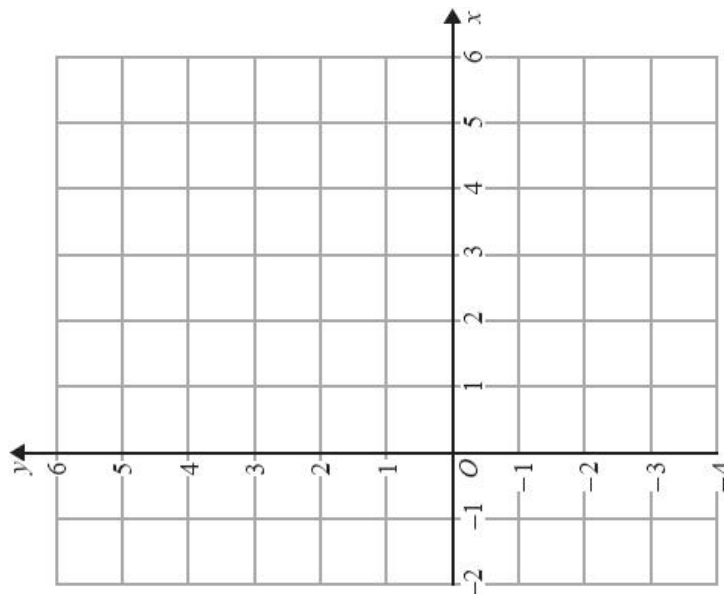

.....(4)

12. The table shows some information about the weights of oranges.

Weight (w grams)	Frequency
$0 < w \leq 20$	
$20 < w \leq 30$	15
$30 < w \leq 50$	
$50 < w \leq 60$	13
$60 < w \leq 75$	15
$75 < w \leq 100$	10

(a) Use the histogram to complete the table.(2)

(b) Use the table to complete the histogram.(2)

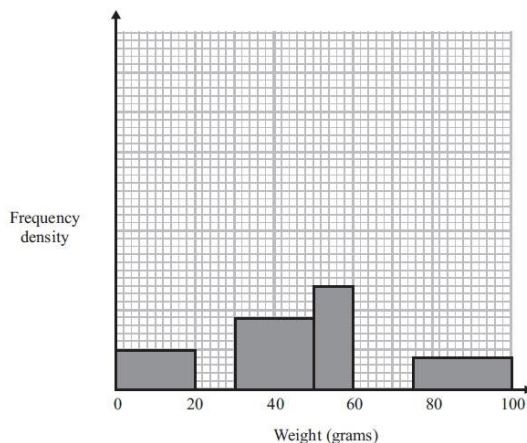

13. The diagram shows two triangles, **A** and **B**.

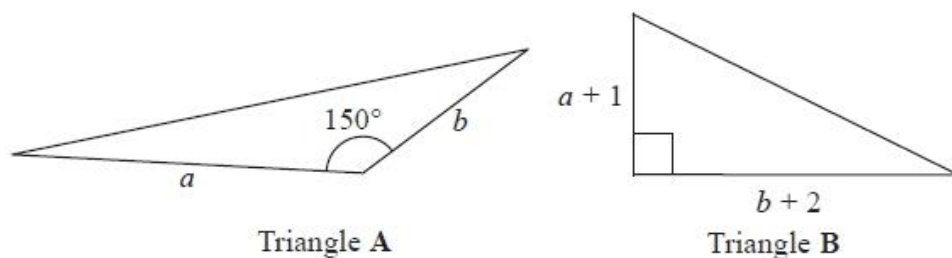

Diagram NOT accurately drawn

The area of triangle **B** is 3 times the area of triangle **A**.

Given that $b > 4$, find an expression for a in terms of b .

$a = \dots\dots\dots$

(Total 5 marks)

14.

Diagram **NOT**
accurately drawn

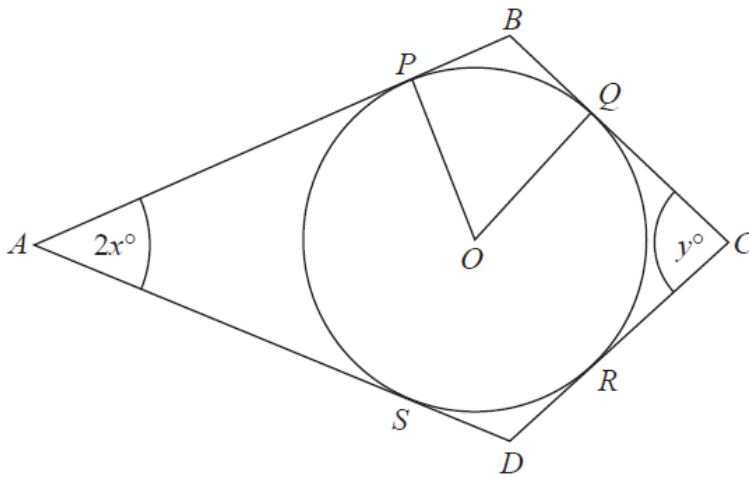

P , Q , R and S are points on the circumference of a circle, centre O .
 APB , BQC , CRD and DSA are tangents to the circle.
 $ABCD$ is a kite.

Angle $PAS = 2x^\circ$
Angle $QCR = y^\circ$

Find an expression in terms of x and y for the size, in degrees, of the angle POQ .
Give your expression in its simplest form.
Give reasons for your answer.

(Total 5 marks)

15.

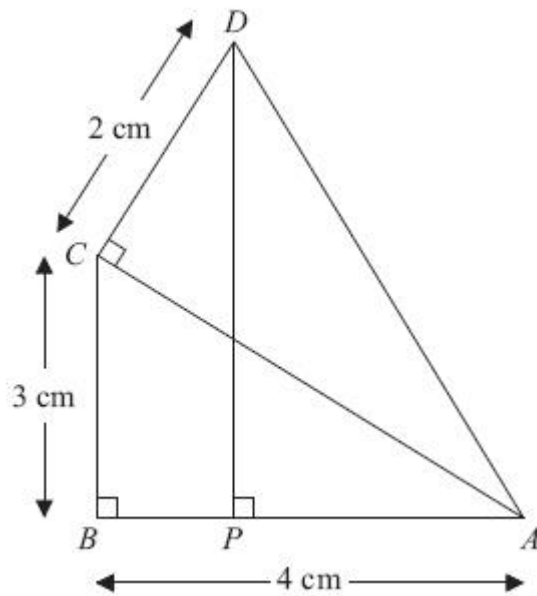

Diagram NOT
accurately drawn

In the diagram,

ABC , ACD and APD are right-angled triangles.

$AB = 4$ cm.

$BC = 3$ cm.

$CD = 2$ cm.

Work out the length of DP .

.....

(Total 5 marks)

- *16. A is the point with coordinates $(1, 3)$
 B is the point with coordinates $(4, -1)$
The straight line L goes through both A and B .

Is the line with equation $2y = 3x - 4$ perpendicular to line L ?
You must show how you got your answer.

(Total 4 marks)

17.

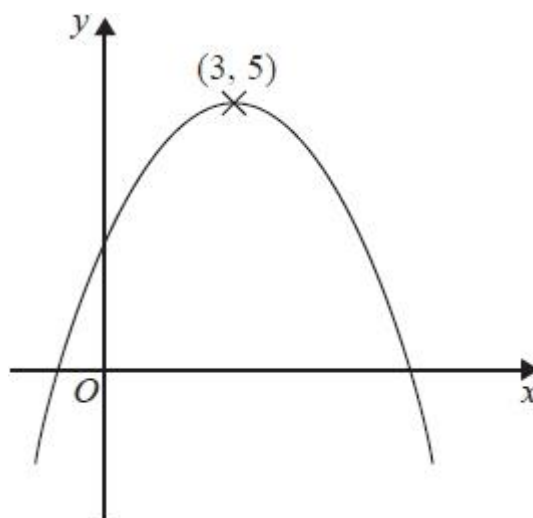

The diagram shows part of the curve with equation $y = f(x)$.
The coordinates of the maximum point of the curve are $(3, 5)$.

(a) Write down the coordinates of the maximum point of the curve with equation

(i) $y = f(x + 3)$

(..... ,))

(ii) $y = 2f(x)$

(..... ,))

(iii) $y = f(3x)$

(..... ,))

(3)

The curve with equation $y = f(x)$ is transformed to give the curve with equation $y = f(x) - 4$

(b) Describe the transformation.

.....

(1)

(Total 4 marks)

18. $f(x) = 3x - 2$

$$g(x) = \frac{10}{x + 2}$$

(a) Express the inverse function f^{-1} in the form $f^{-1}(x) = \dots$

$f^{-1}(x) = \dots$

(2)

(b) Find $gf(x)$
Simplify your answer.

$gf(x) = \dots\dots\dots$

(2)

(Total 4 marks)

***19.**

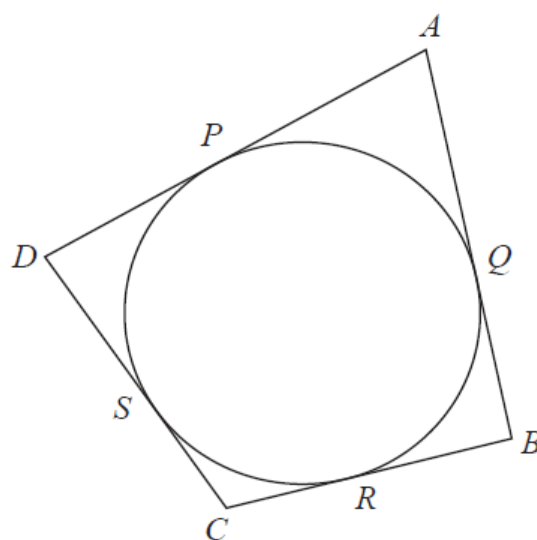

Diagram **NOT**
accurately drawn

$ABCD$ is a quadrilateral.
 AB, AD, BC and CD are tangents to a circle.

The tangents touch the circle at Q, P, R and S respectively.
 AC goes through the centre of the circle.

$AP : PD$ is in the ratio $3 : 2$

$AQ : QB$ is in the ratio $3 : 2$

Prove that $ABCD$ is a kite.

(Total is 5 marks)

- *20.** Given that a and b are two consecutive even numbers, prove algebraically that $\left(\frac{a+b}{2}\right)^2$ is always 1 less than $\frac{a^2 + b^2}{2}$.

(Total 5 marks)

21. Clive wants to estimate the number of bees in a beehive.
Clive catches 50 bees from the beehive.

He marks each bee with a dye.
He then lets the bees go.

The next day, Clive catches 40 bees from the beehive.
8 of these bees have been marked with the dye.

(i) Work out an estimate for the number of bees in the beehive.

..... bees

(ii) Write down any assumptions you have made.

.....
.....
.....

(Total 4 marks)

*22. Prove algebraically that the difference between the squares of any two consecutive integers is equal to the sum of these two integers.

(Total 4 marks)

23. Hannah has an empty box.
She puts some crème tangerines and some nice apple tarts into the box.

The ratio of the number of crème tangerines to the number of nice apple tarts is 1 : 4

Hannah's sister Holly takes at random 2 items from the box.

The probability that she takes 2 crème tangerines is $\frac{6}{155}$.

How many crème tangerines did Hannah put into the box?

.....
(Total 4 marks)

- *24. Zara is the manager of a shop.
The table gives information about the expenses the shop had last year.

Expense	Wages	Rent	Goods	Other expenses
Amount	£92 000	£10 800	£72 000	£7000

This year

the wages will increase by 7.5%,
the rent will be $\frac{7}{9}$ of the rent last year,
the other expenses will halve.

Zara wants to increase the amount of money she spends on goods.
She also wants the total expenses the shop has this year to be the same as last year.
Can Zara increase the amount of money she spends on goods?

(Total 4 marks)

25. Solve the simultaneous equations:

$$\begin{aligned}x^2 + y^2 &= 18 \\ y &= 5 - x\end{aligned}$$

Give your answer correct to 3 significant figures.

(Total 5 marks)

**26. Tony designs a game.
It costs £1.20 to play the game.**

The probability of winning the game is $\frac{3}{10}$

The prize for each win is £2.50

150 people play the game.

Work out an estimate of the profit that Tony should expect to make.

£
(Total 4 marks)

27.

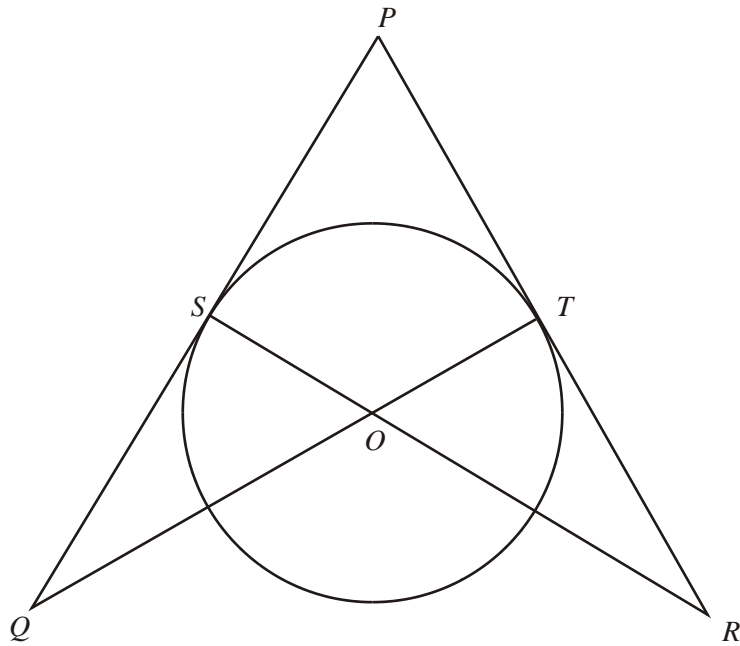

Diagram **NOT** accurately drawn

S and *T* are points on a circle, centre *O*.
PSQ and *PTR* are tangents to the circle.
SOR and *TOQ* are straight lines.

(a) Prove that triangle *PQT* and triangle *PRS* are congruent.

(3)

Asif says that triangle STQ and triangle STR have equal areas.

(b) Explain why Asif is correct.

.....

.....

.....

.....

(2)

(Total 5 marks)

28. The diagram shows a cylinder inside a cone on a horizontal base.

The cone and the cylinder have the same vertical axis.
The base of the cylinder lies on the base of the cone.

The circumference of the top face of the cylinder touches the curved surface of the cone.

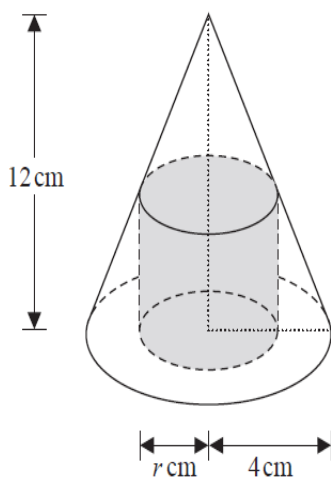

Diagram NOT accurately drawn

Volume of cone $\frac{1}{3} \pi r^2 h$

Curved surface area of cone $= \pi r l$

The height of the cone is 12 cm and the radius of the base of the cone is 4 cm.

- (a) Work out the curved surface area of the cone.
Give your answer correct to 3 significant figures.

..... cm²
(3)

The cylinder has radius r cm and volume V cm³

- (b) Show that $V = 12\pi r^2 - 3\pi r^3$

(3)

(Total 6 marks)

29.

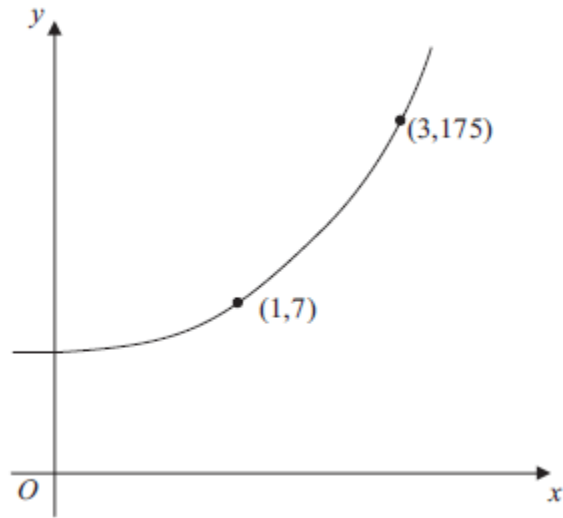

The sketch shows a curve with equation

$$y = ka^x$$

where k and a are constants, and $a > 0$

The curve passes through the points $(1, 7)$ and $(3, 175)$.

Calculate the value of k and the value of a .

$k = \dots\dots\dots$

$a = \dots\dots\dots$

(Total 3 marks)

30.

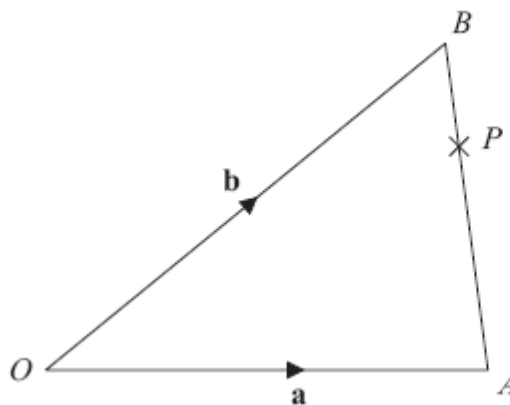

Diagram **NOT**
accurately drawn

OAB is a triangle.

$$\overrightarrow{OA} = \mathbf{a}$$

$$\overrightarrow{OB} = \mathbf{b}$$

(a) Find \overrightarrow{AB} in terms of \mathbf{a} and \mathbf{b} .

.....
(1)

P is the point on AB such that $AP : PB = 3 : 1$

- (b) Find \overrightarrow{OP} in terms of \mathbf{a} and \mathbf{b} .
Give your answer in its simplest form.

.....
(3)

(Total 4 marks)

31. Here are the first 4 terms of a quadratic sequence.

7 18 33 52

Find an expression, in terms of n , for the n th term of the sequence.

(Total 3 marks)

32. The graph shows the velocity, v metres per second, of a rocket at time t seconds.

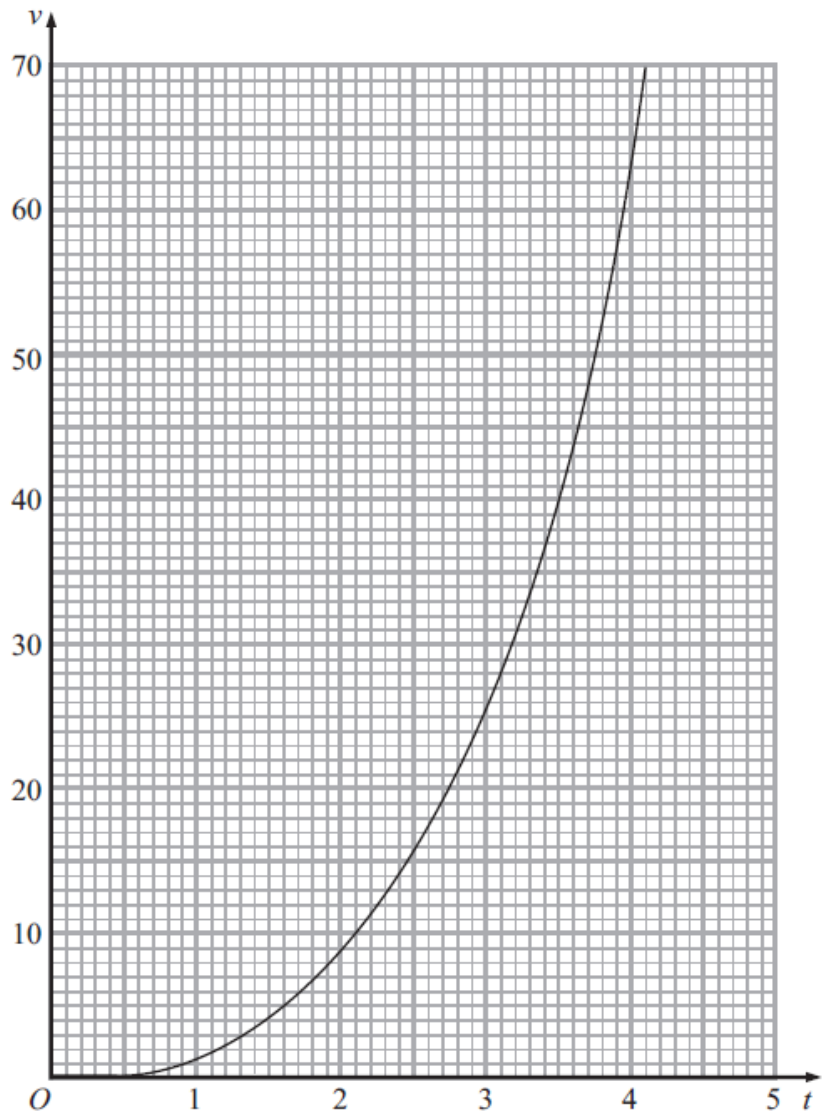

Find an estimate for the rate of change of the velocity of the rocket at $t = 2$

..... m/s^2
(Total 3 marks)

33. The line **L** is a tangent to the circle $x^2 + y^2 = 45$ at the point $(-3, 6)$.

The line **L** crosses the x -axis at the point P .

Work out the coordinates of P .

.....
(Total 4 marks)