

77 PROBLEMS

Ready to project versions of the problems and solutions available on

www.mathsbox.org.uk

Averages 2 PROBLEM SOLVING

The scores of the first 6 competitors in a contest have a mean of 28 points

When the 7th competitor is included the mean decreases to 27 points.

How many points did the 7th competitor score?

MONEY 10 PROBLEM SOLVING

Daniel is given his wages.

He spends 40% of his wages.

He gives $\frac{1}{4}$ of his wages to his mum.

He saves the rest of his wages.

If Daniel gave £30 to his mum, how much money did he save?

Linear equations 5 PROBLEM SOLVING

The pentagon and the square have the same perimeter. Calculate the area of the square

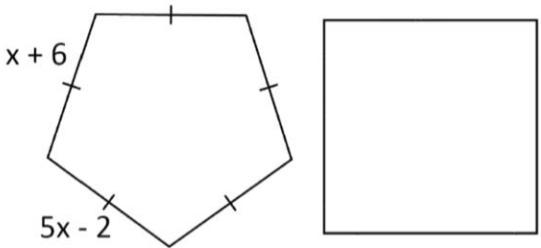

The diagram shows a pentagon with side lengths labeled as $x + 6$ and $5x - 2$. The pentagon has tick marks on its sides, indicating that the top side is equal in length to the right side, and the left side is equal in length to the bottom side. To the right of the pentagon is a square.

a, b, and c are three different positive integers where

$$\mathbf{a + b + c = 10}$$

What is the maximum value of **abc**?

a, b, and c are three integers where

$$abc = -12$$

What is the maximum value
of $a + b + c$?

What percentage of the triangle is shaded?

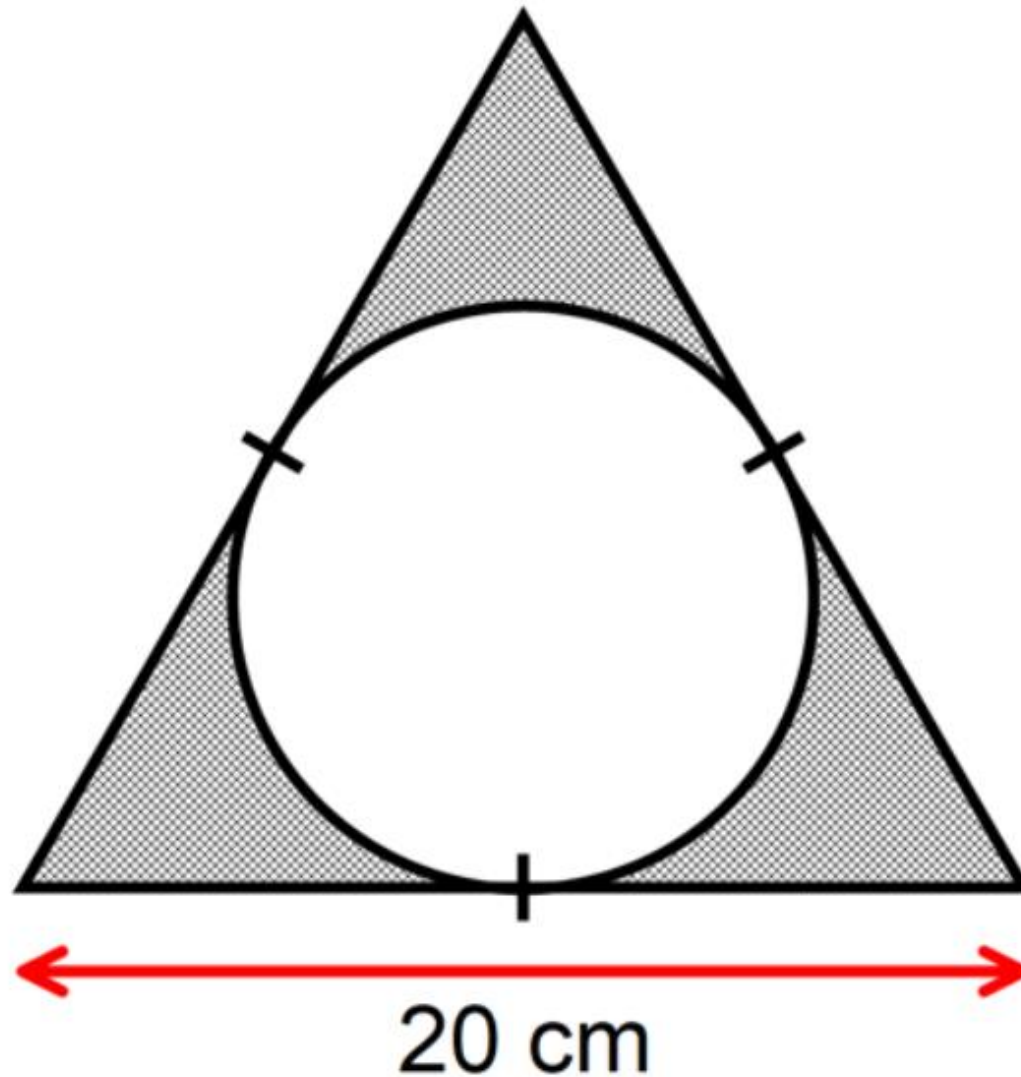

The regular hexagon has side length 10 cm. Show that exactly 50% of the hexagon is shaded.

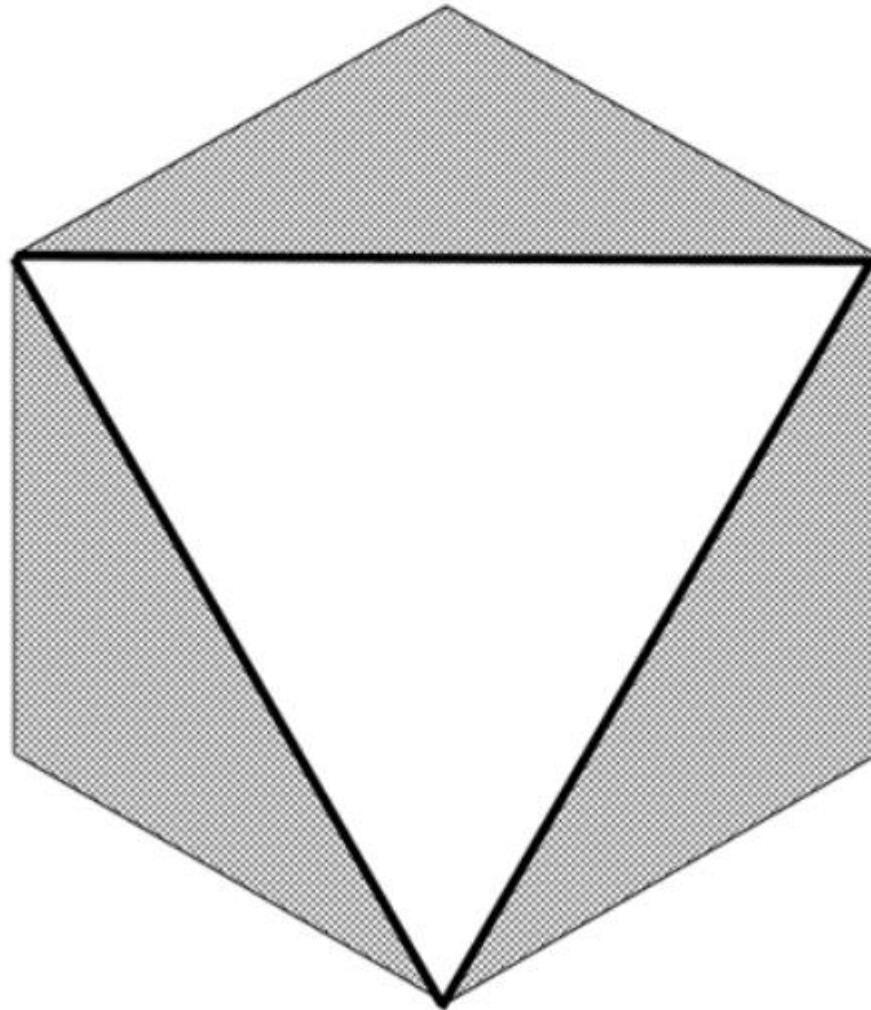

The square has side length 12 cm. What percentage of the circle is shaded?

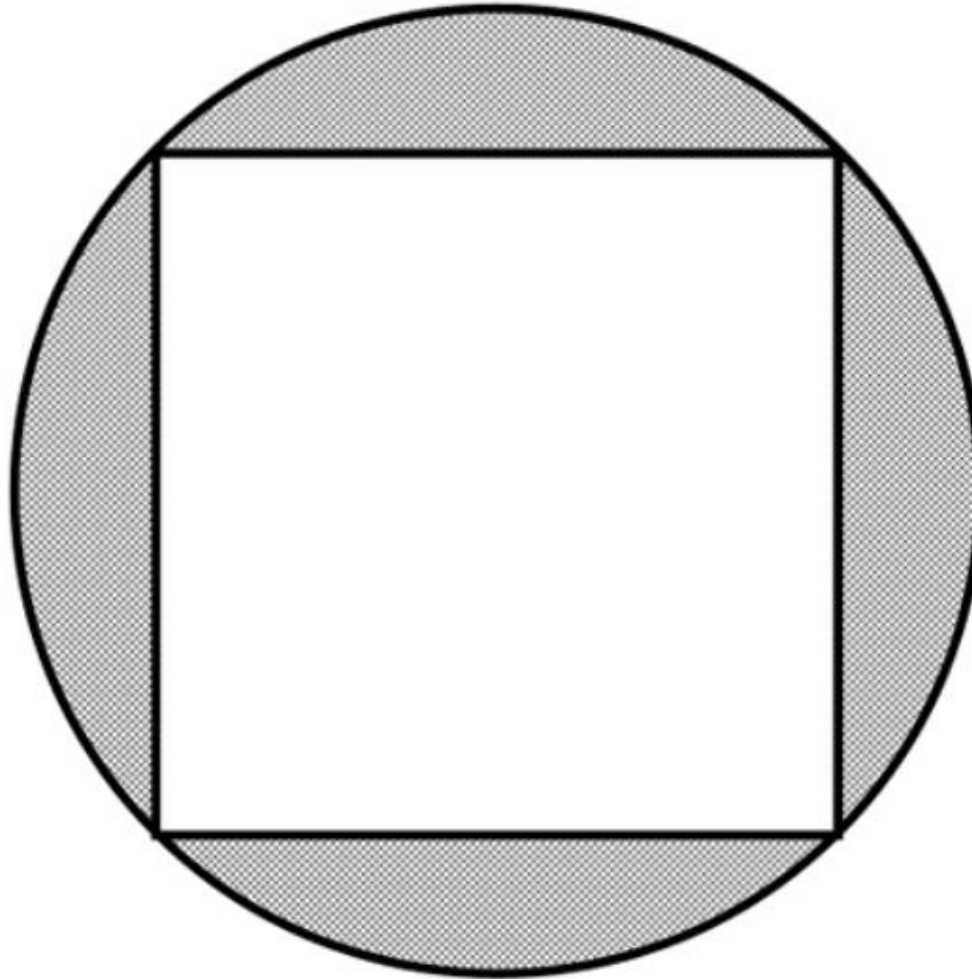

The large square has side length 10 cm.
Calculate the shaded area.

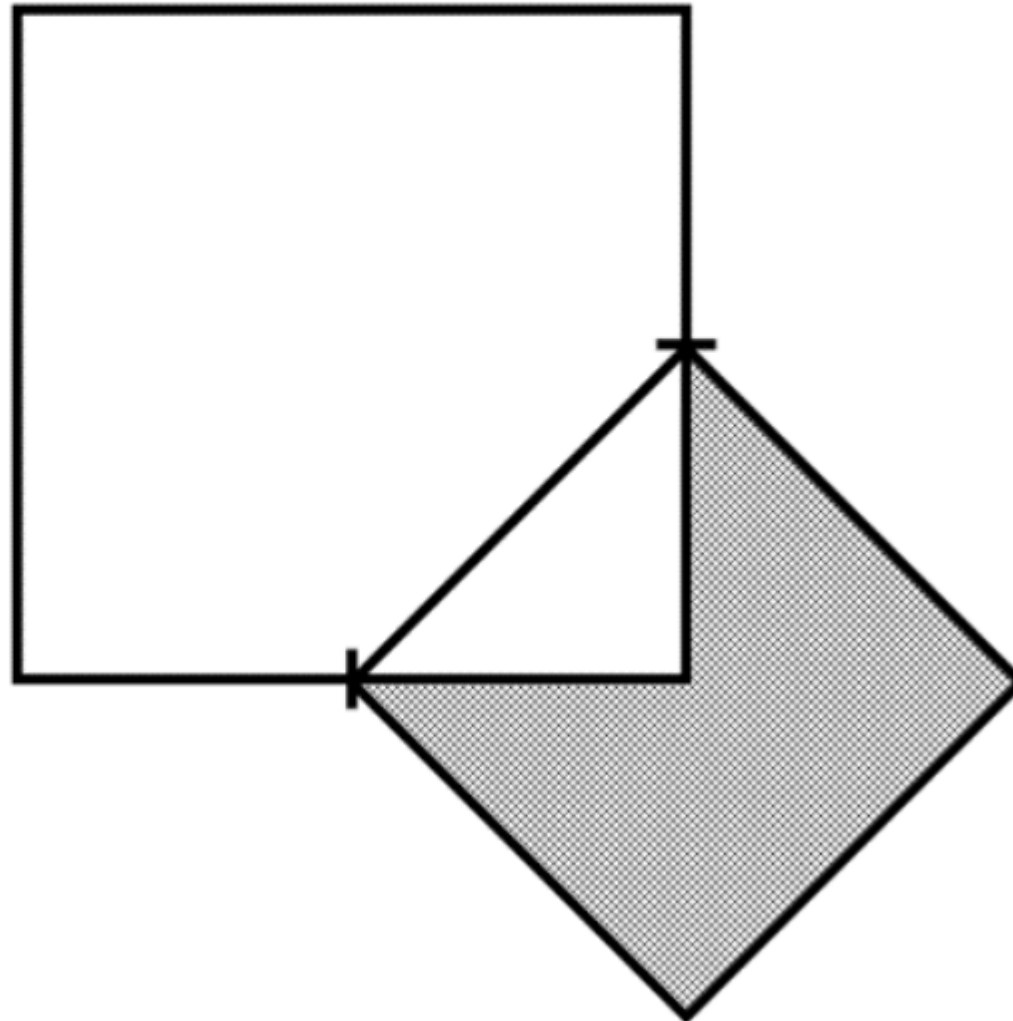

The circle has an area of $36\pi \text{ cm}^2$
Calculate the shaded area.

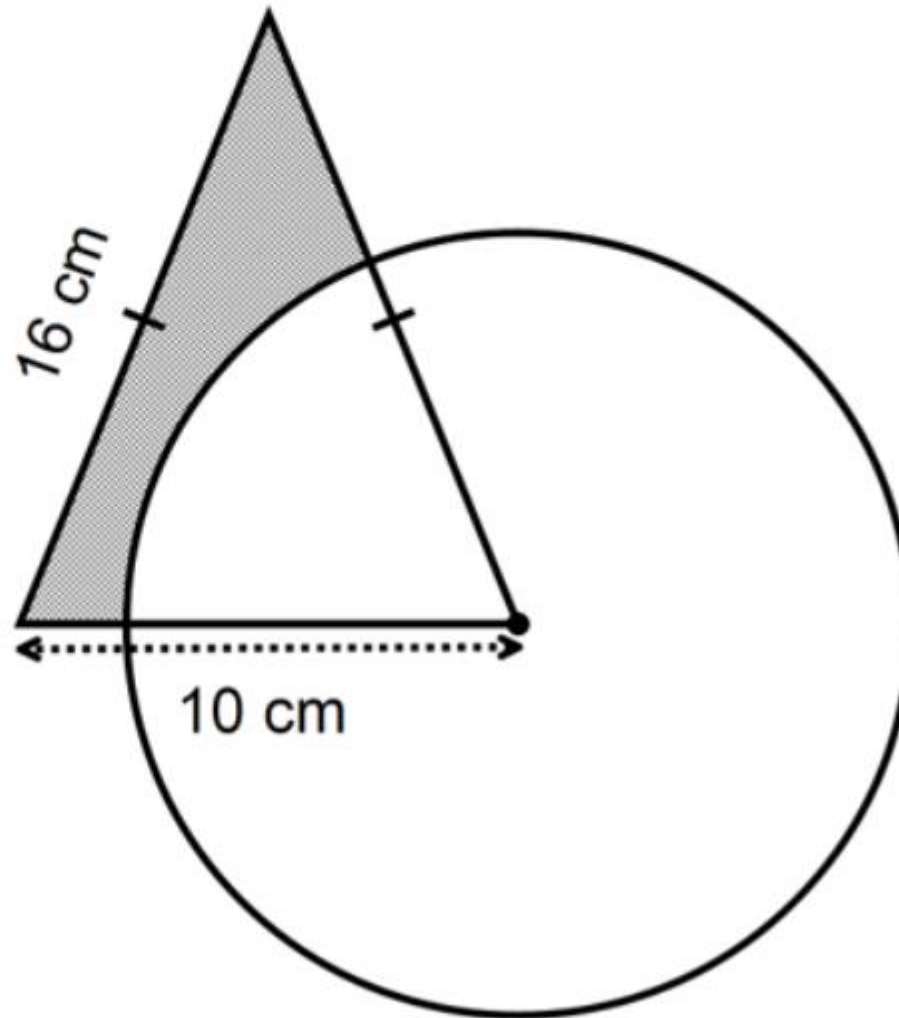

The unshaded and shaded areas in the sector below are equal.

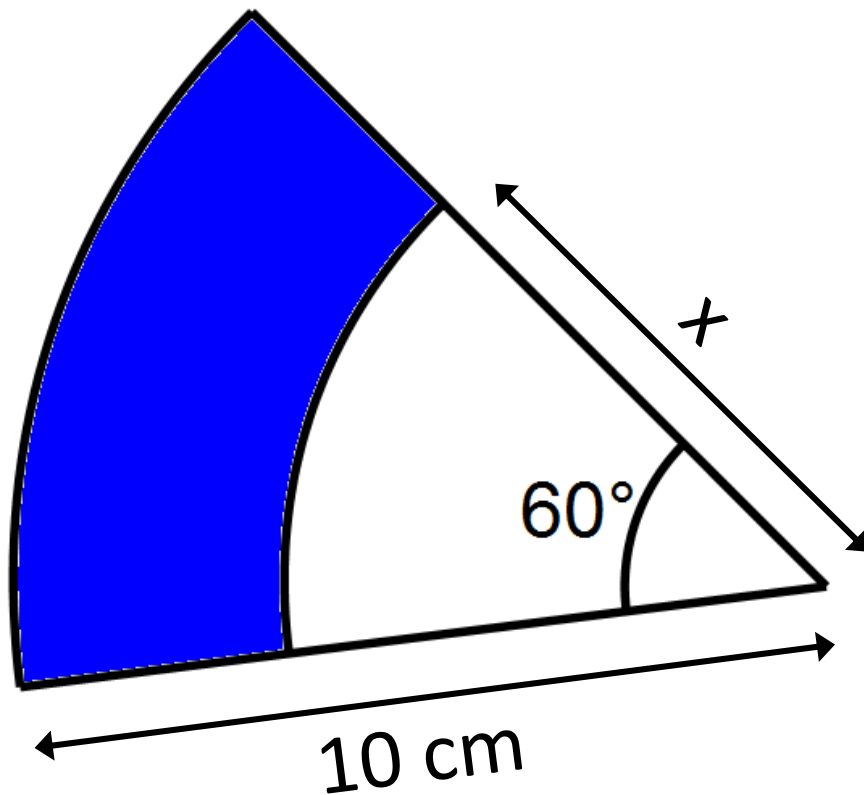

Calculate x

Calculate the ratio of the blue to white area of the sector.

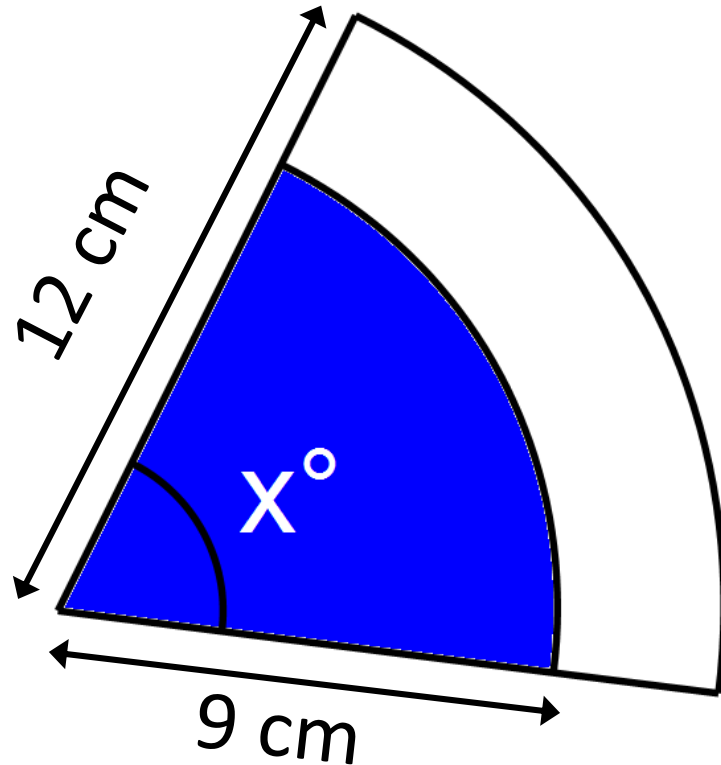

Five integers have

- a median of 17
- a mode of 12
- a range of 8
- a mean of 16

If the smallest number is 12, what are the other numbers?

The scores of the first 6 competitors in a contest have a mean of 28 points

When the 7th competitor is included the mean decreases to 27 points.

How many points did the 7th competitor score?

Jake worked for 5 days and his earnings including tips had a mean of £28.00 per day.

Each day he earned £2 more than the day before. How much did he earn on the 5th day?

Use the digits

1, 2, 3, 3, 5, 6

to fill in the missing numbers to
make the answer closest to zero

$$\boxed{} \times \boxed{} \boxed{} - \boxed{} = \boxed{} \boxed{}$$

Use the digits

2, 3, 4, 5

to fill in the missing numbers to
make the largest possible answer

$$\begin{array}{|c|c|} \hline & \\ \hline \end{array} + \begin{array}{|c|} \hline \\ \hline \end{array} \times \begin{array}{|c|} \hline \\ \hline \end{array} = \begin{array}{|c|c|} \hline & \\ \hline \end{array}$$

Use the digits

2, 4, 6, 8

to fill in the missing numbers to
make the answer closest to zero

$$\boxed{} \boxed{} - \boxed{} \times \boxed{}$$

Find 2 fractions between

$$\frac{1}{3} \text{ and } \frac{1}{2}$$

with denominators
less than 30

Arthur makes a 12% profit when he sells an antique cabinet. He gives one-quarter of the profit to his partner and pays the rest, £40.50 into his bank account. How much did he sell the cabinet for?

An alloy is made by mixing metals A and B
in the ratio 3 : 5

Metal A costs £42 per kg

Metal B costs £20 per kg

How much would it cost to make 400g of
the alloy?

40% of the members of a film club are over the age 60. One quarter of the members aged less than 60 are females. There are 63 members who are male and less than 60.

How many members are there in the club?

Alex gives Bob half of his football cards. Bob gives Charlie one third of the cards he receives from Alex. Charlie then keeps the 12 cards he is given.

How many cards did Alex have at the start?

If the range of the following is 32, calculate the mean.

$$x \quad x \quad 3x \quad 5x$$

Alex, Bella and Cary divide a prize in the ratio $x : x + 1 : 3x$ respectively.

If Cary gets £24 more than Alex, how much money did Bella get?

Alfie, Burt, Chris and Dom share a prize.

Alfie gets one-sixth of the prize.

Burt gets 25% of the prize.

The rest is shared between Chris and Dom in the ratio 2 : 3.

If Dom's share is £63, how much does Alfie get?

Adam, Bella and Carl collect tokens in a game.
Bella has 10 more tokens than Adam.
Carl has 8 more tokens than Bella.

Altogether they have 91 tokens.

How many tokens does Adam have?

Work out the size of the smallest angle.

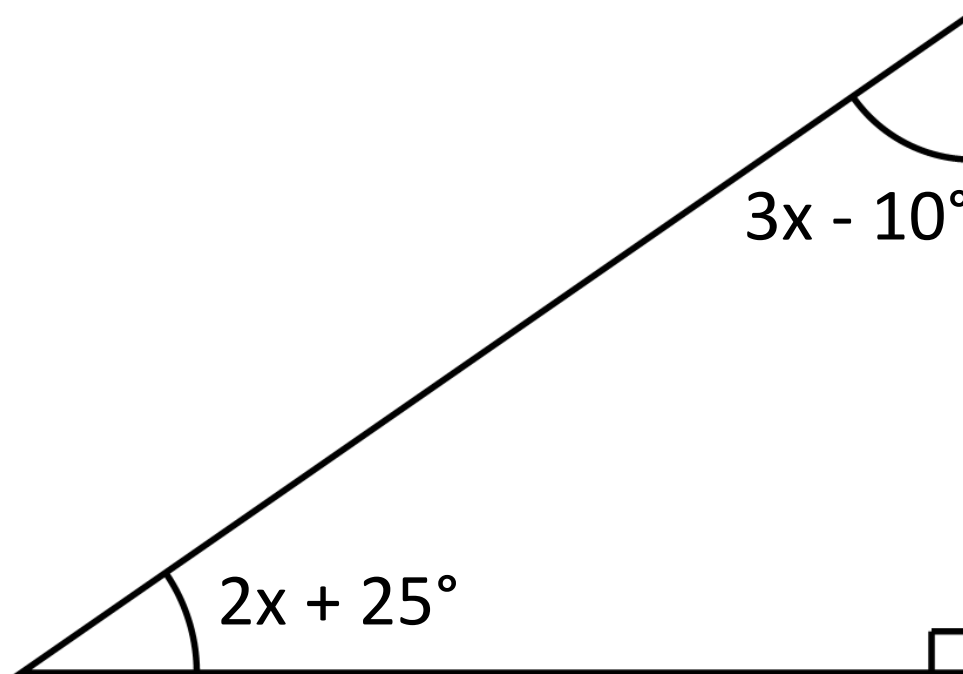

Is this an isosceles triangle?
Show how you decide

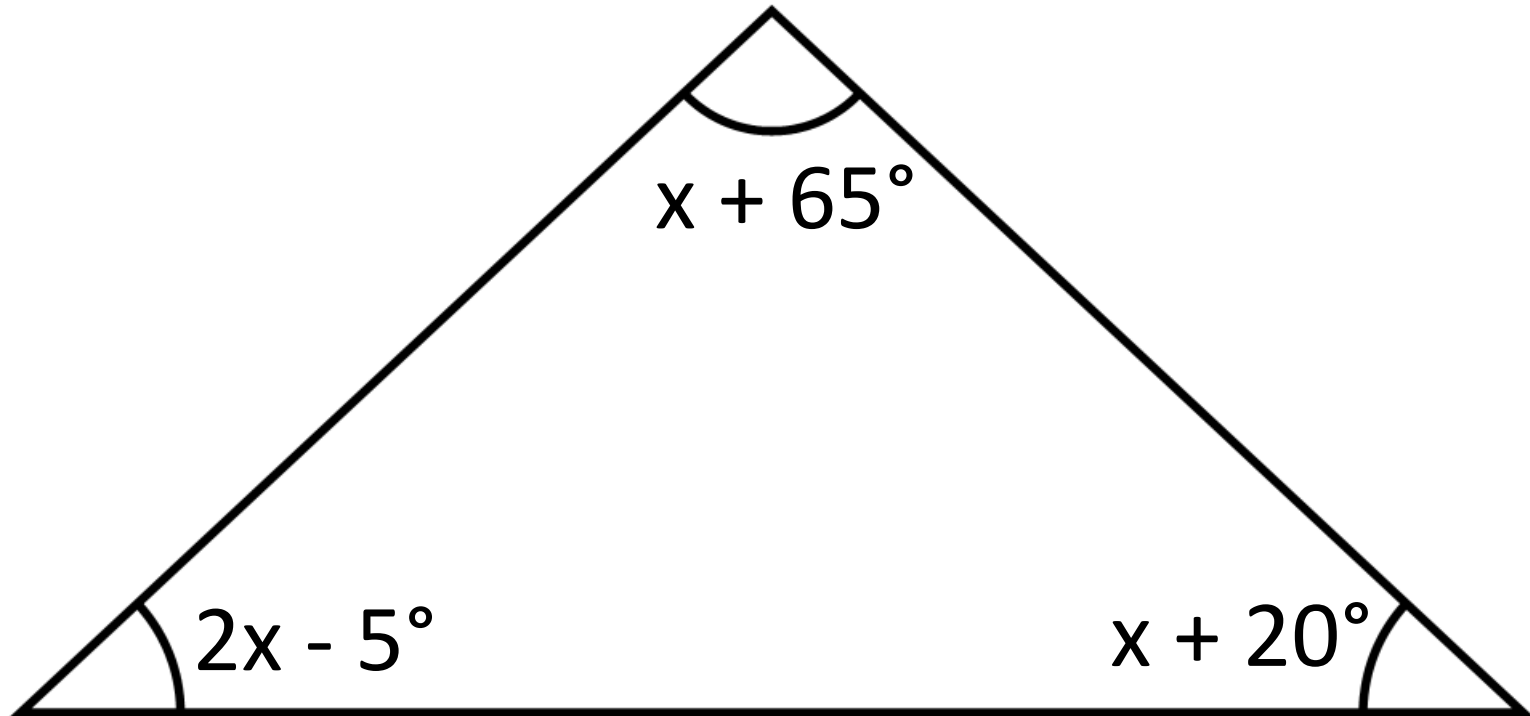

Work out the perimeter of the triangle

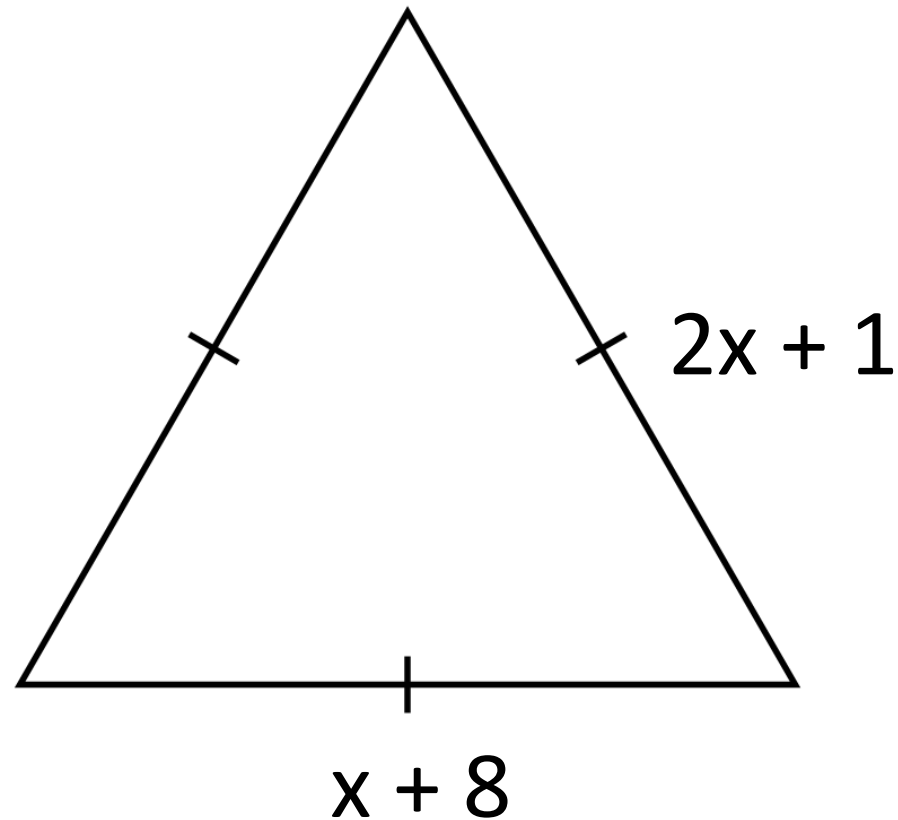

The pentagon and the square have the same perimeter. Calculate the area of the square

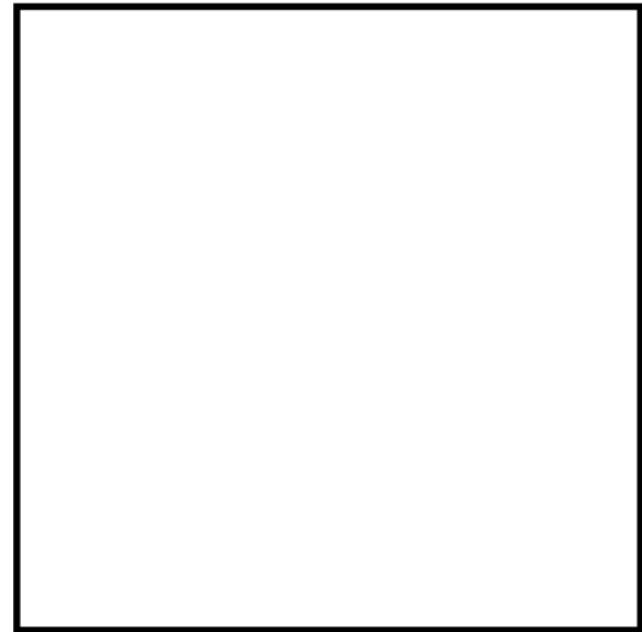
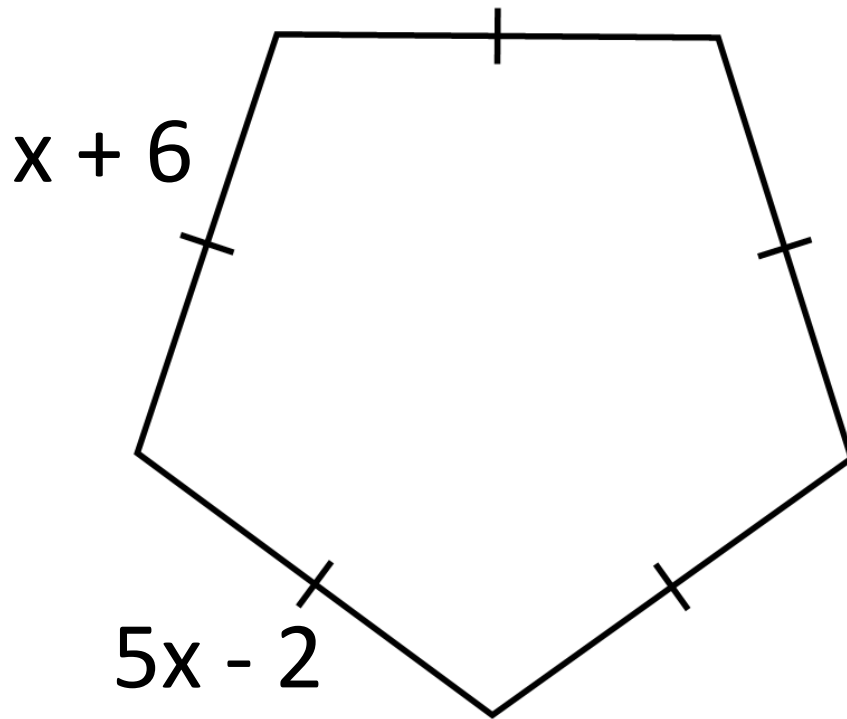

Calculate the difference between the largest and smallest angle in the quadrilateral

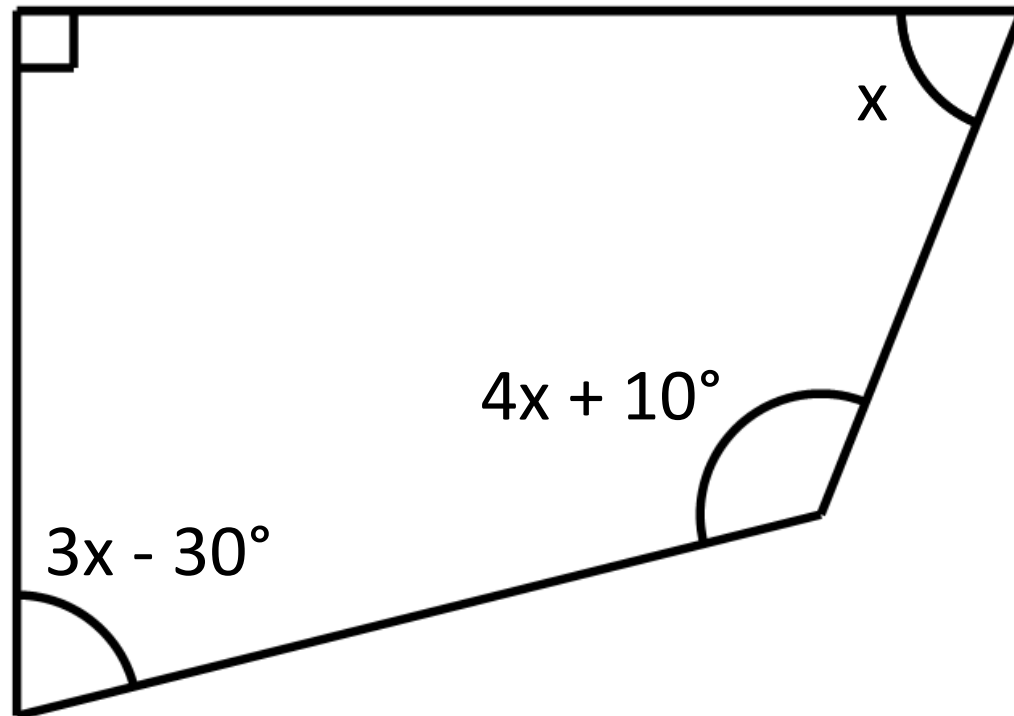

The totals of the rows and columns are shown. Find the values of a , b and c .

a	2a	b	25
2b	a	c	45
c	a	c	45
45	20	50	

Find x and y if

$$\frac{x}{4} \text{ of } y = 270 \quad \text{and} \quad \frac{y}{x} = 120$$

What type of triangle is this?
(Not drawn to scale)

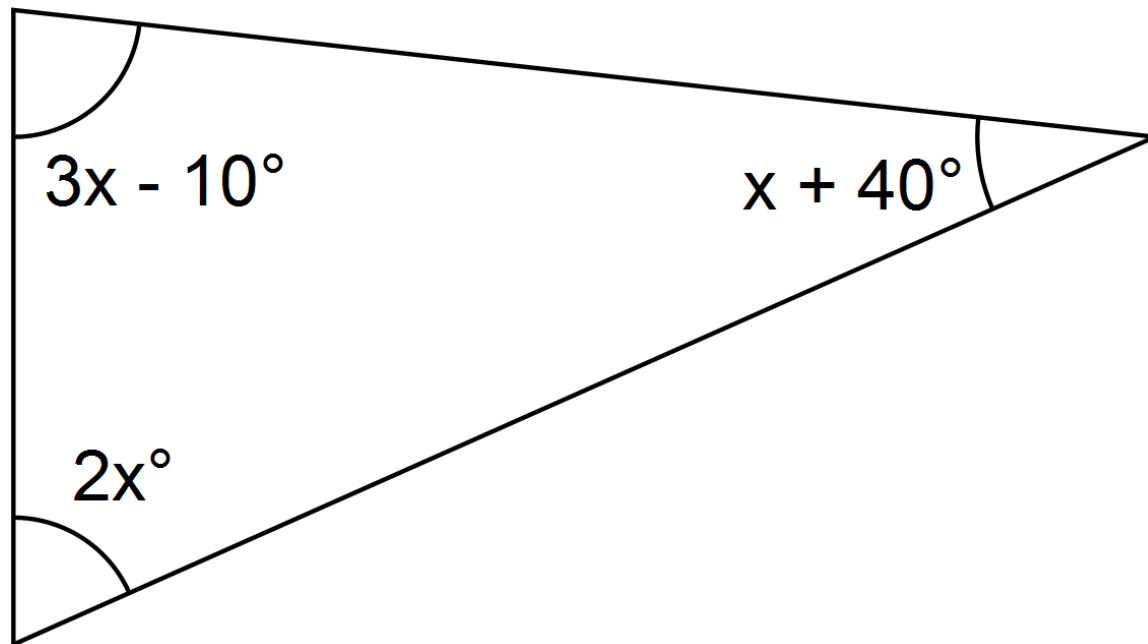

The perimeter of the rectangle is 50 cm.
Calculate the area.

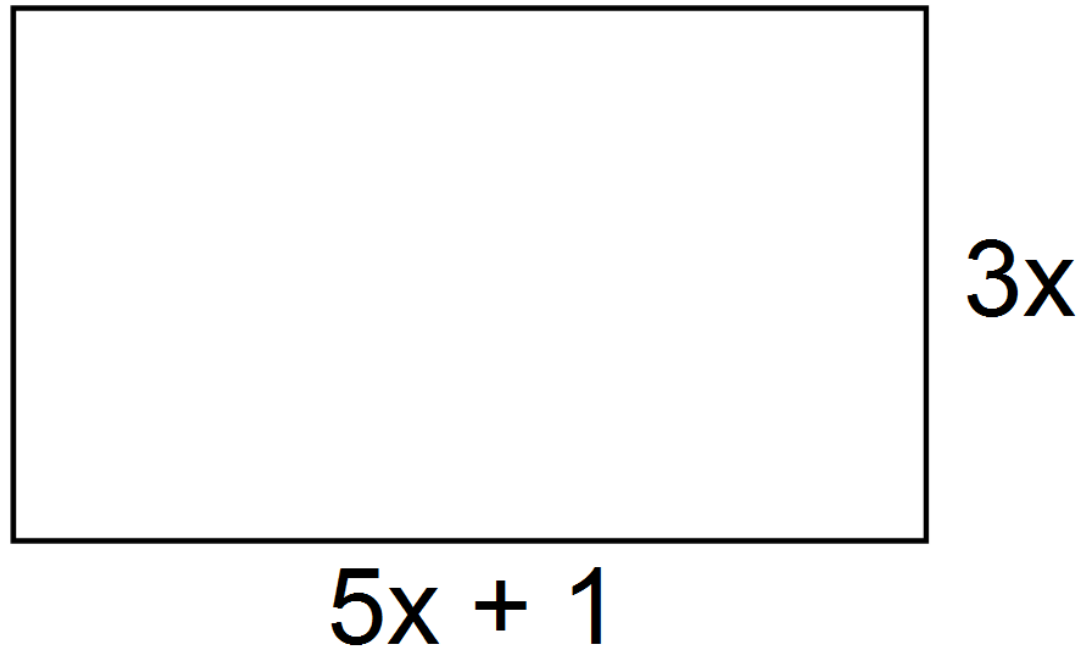

Emily has 4 different coins in her pocket.

Half of coins are worth less than 50p

What are the minimum and maximum totals that Emily could have?

Jacob has 10p, 20p and 50p coins in his pocket.
One quarter of the coins are 50p coins with a
total of £3.00

The ratio of the number of 10p coins to the
number of 20p coins is 2 : 7

How much money does Jacob have?

Daniel has a pocket full of coins.

One half of the coins are £1 coins

One third of the coins are 20p coins.

The rest of the coins are 50p coins with a total of £1.50

What is the total value of Daniel's coins?

Simons spent £28 over 7 days. Each day he spent 50p more than the amount spent on the previous day.

How much did Simon spend on the 1st day?

Jack buys 50 pens for 65p each.

He sells 80% of the pens making a 20% profit on each.

To sell the remainder of the pens he is forced to reduce his price making a loss of 9p on each.

Assuming he sells all of his pens calculate his total profit.

James sells $\frac{3}{5}$ of his games for £4.50 each.

If he has 8 games left, how much money did he make from selling his games?

Tom's Taxis charge a fixed fee of £3.20 and then 40p for each mile travelled.

Carl's Cars charge a fixed fee of £2.75 and then 55p for each mile travelled

Which company would be cheapest and by how much for a 12 mile journey?

Tara's Taxis charge a fixed fee of £1.50 and then 60p per mile for the first 5 miles. Any additional miles travelled are charged at a rate of 45p per mile.

Dani uses Tara's Taxis and pays £7.65 for her journey. How many miles did Dani travel?

Sam withdraws some money from his bank account. He spends $\frac{1}{5}$ of this money on a present for his sister. He gives 25% of the money to his mum.

If Sam has £44 left, how much did he spend on a present for his sister?

Daniel is given his wages.

He spends 40% of his wages.

He gives $\frac{1}{4}$ of his wages to his mum.

He saves the rest of his wages.

If Daniel gave £30 to his mum, how much money did he save?

Alfie has a £10 note

He buys 3 pens costing £1.45 each and some pencils costing 90p each.

If Alfie gets £2.05 change, how many pencils does he buy?

Cakes
£2.80 each
3 for 2 offer

Plates
95p each
Buy 1 get one free

Dani is buying cakes and plates for an event.
She buys 18 cakes and 18 plates.

She pays with the following notes
£20, £20, £10

How much change will she get?

Complete the table to show the missing percentages and amounts

	£	£240	£
20%			£120
%	£40		
%	£20	£12	

Complete the table to show the missing percentages and amounts

	£80		
	£16		£30
30%		£36	
	£8		£15

$x\%$ of $y = \text{£}16$ and $(x + 5)\%$ of $y = \text{£}20$

Find the value of x and y

In a recent advert it is stated that exactly 96% of cats preferred the chosen brand.

What is the smallest possible of number of cats tested in the survey?

Complete the following using all of the numbers

1, 2, 3, 4, 5, 6

to find the **number closest to 300**

			-			
--	--	--	---	--	--	--

Complete the following using all of the numbers

1, 2, 3, 4, 5, 6

to find the **smallest odd number**

			-			
--	--	--	---	--	--	--

Complete the following using all of the numbers

1, 2, 3, 4, 5, 6

to find the **biggest odd number**

			-			
--	--	--	---	--	--	--

Complete the following using all of the numbers

1, 2, 3, 4, 5, 6

to find the **smallest multiple of 5**

			-			
--	--	--	---	--	--	--

Complete the following using all of the numbers

1, 2, 3, 4, 5, 6

to find the **smallest even number**

			-			
--	--	--	---	--	--	--

Complete the following using all of the numbers

1, 2, 3, 4, 5, 6

to find the **number closest to 500**

			+			
--	--	--	---	--	--	--

Complete the following using all of the numbers

1, 2, 3, 4, 5, 6

to find the **biggest odd number**

			+			
--	--	--	---	--	--	--

Complete the following using all of the numbers

1, 2, 3, 4, 5, 6

to find the **smallest even number**

			+			
--	--	--	---	--	--	--

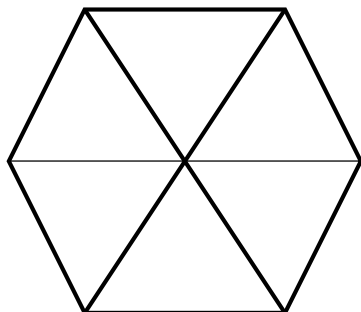

The sections of the spinner are shaded using red, blue and yellow.

The probability of getting red is greater than probability of getting blue. The probability of getting yellow is greater than the probability of getting red.

The cost of playing is £1 per spin but a prize of £2 is paid out if the spinner lands on blue.

If 48 people have a go, how much profit would you expect to make?

A bag contains red, blue, yellow and green counters.

One quarter of the counters are red.

One third of the tiles that are not red are blue

The ratio of the number of yellow to green tiles is 1 : 3

There are 4 red counters in the bag.

What is the probability that a counter picked at random is green?

A bag contains gold and silver coins.

The probability of picking a gold coin at random is $\frac{2}{7}$

There are 20 silver coins in the bag.

If a silver coin is removed, what is the probability of picking a gold coin?

	Maximum angle of elevation	Maximum length of the ladder
LADDER A	70°	4 m
LADDER B	67°	4.2 m

Which ladder can reach the highest up a vertical wall?

What is the difference in the maximum heights reached (in cm)?

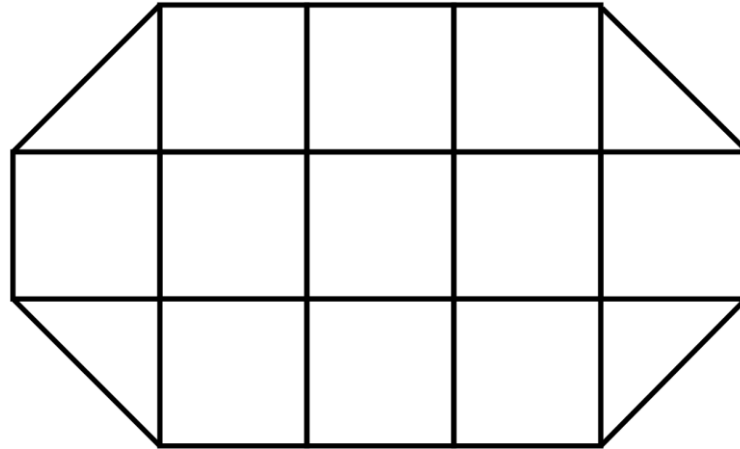

The patio shown above is to be made with 13 square paving slabs each with side length 0.8 m. It will be edged using edging costing £9.40 per metre.

If the paving slabs cost £5.50 each work out the total cost of the slabs and paving.

Zip-it are looking to install a new zip wire at one of their parks as shown in the plan below (not to scale)

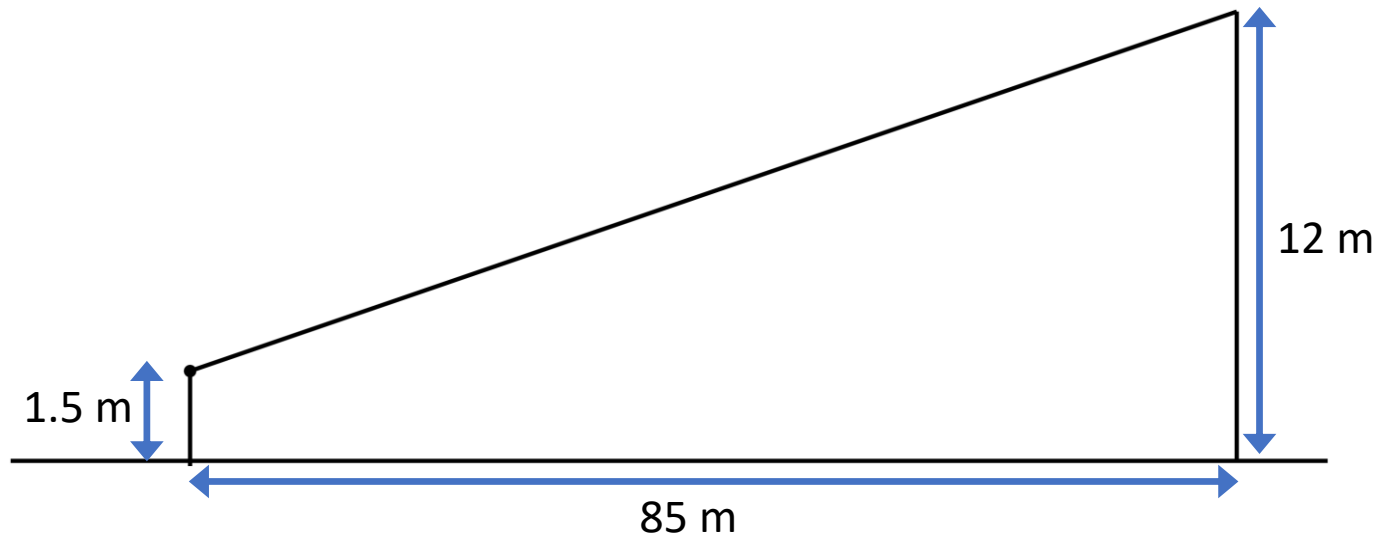

The fixings and safety harness cost £530. The wire costs £42 per metre and Zip-it needs to buy the length required plus an additional 10% for fastenings.

What will be the total cost of the equipment needed to install the new zip wire?

In a regular polygon the ratio of the exterior angle to the interior angle at each vertex is 1 : 8.

How many sides does the polygon have?

In a regular polygon the ratio of the exterior angle to the interior angle at each vertex is 1 : 9.

How many sides does the polygon have?

Molly and Emily share a prize in the ratio 2 : 7. If Emily gets £20 more than Molly, how much money did they win altogether?

Two different cuboids, with integer lengths greater than 1, each have a volume of 24 cm^3

What is the difference in their surface areas?

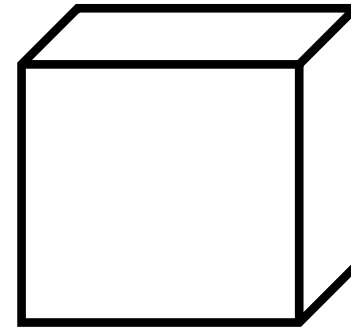
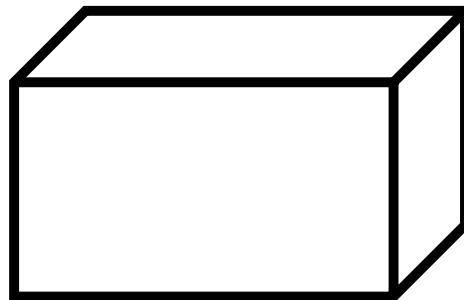

The volume of the hemisphere is the same as the volume of the sphere.

Calculate the difference in the surface areas.

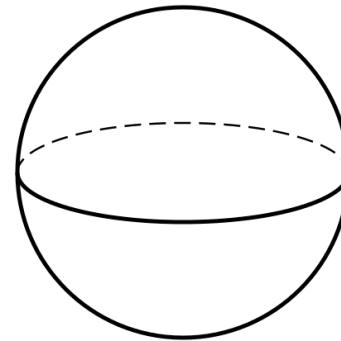
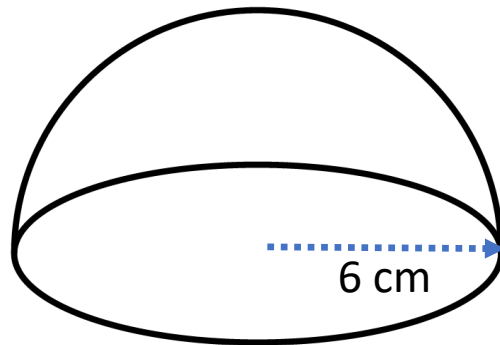

Give your answer correct to 3 significant figures

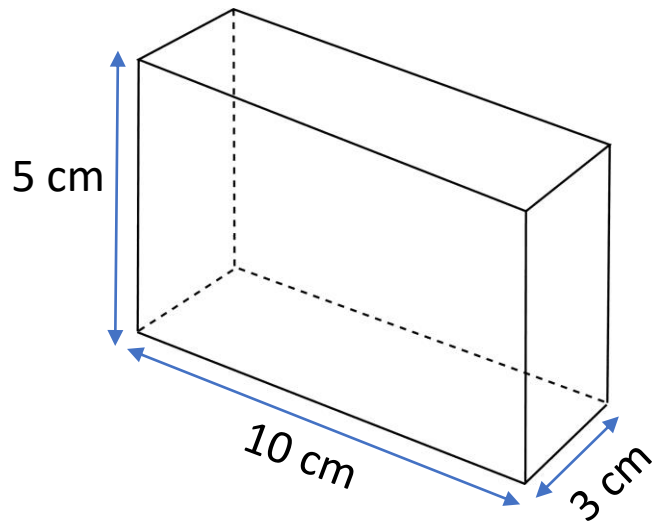

The volume of the cuboid shown is increased by 100% by doubling one of the lengths

What is the smallest possible increase in surface area?

The pendant shown below has a depth of 4 mm and is made from an alloy with density 2.5 g/cm^3

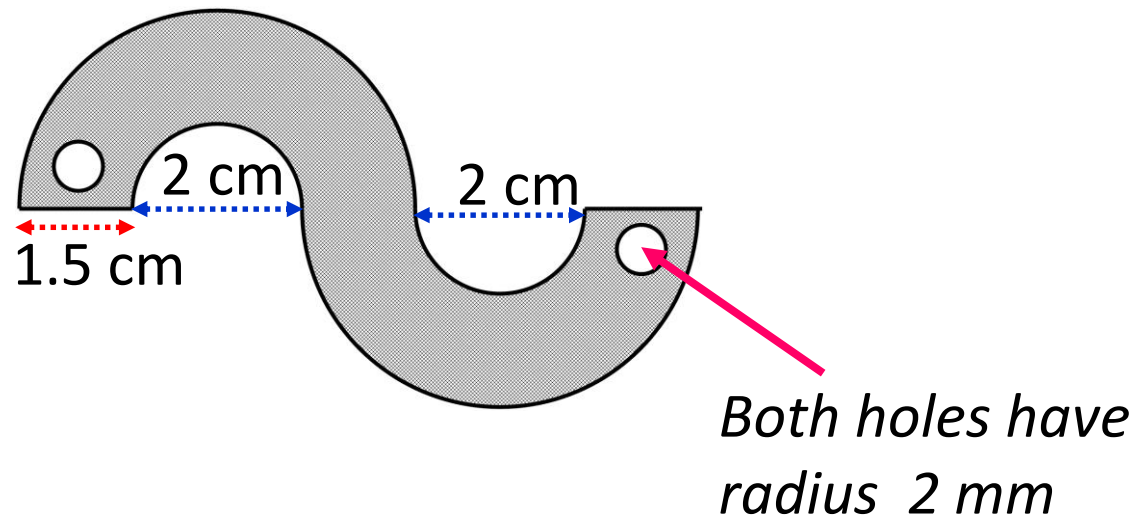

Calculate the mass of the pendant

The tube shown is made from an alloy with a density of 0.6g/cm^3 . The measurements are centimetres and the tube is 8 cm long.

Calculate the mass of the tube.

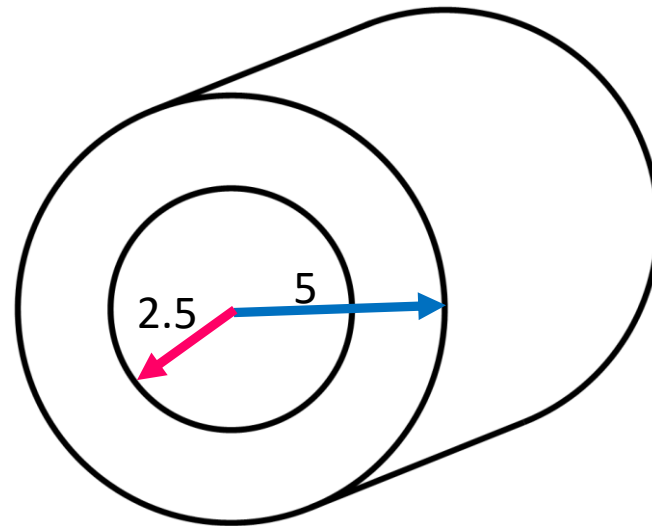

The volume of the cone to the volume of the hemisphere are in the ratio 4:3. Calculate the height of the cone.

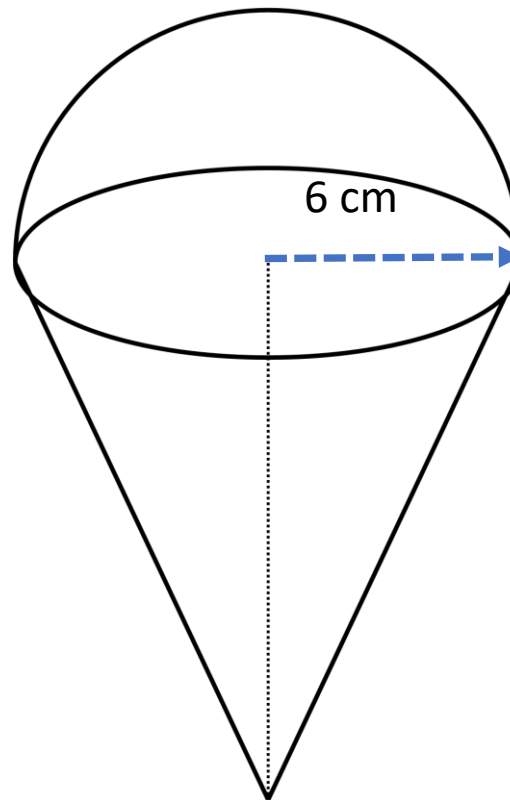

Water flows into the cylindrical tank at a constant rate. After 1 minute there are 40 litres of water in the tank.

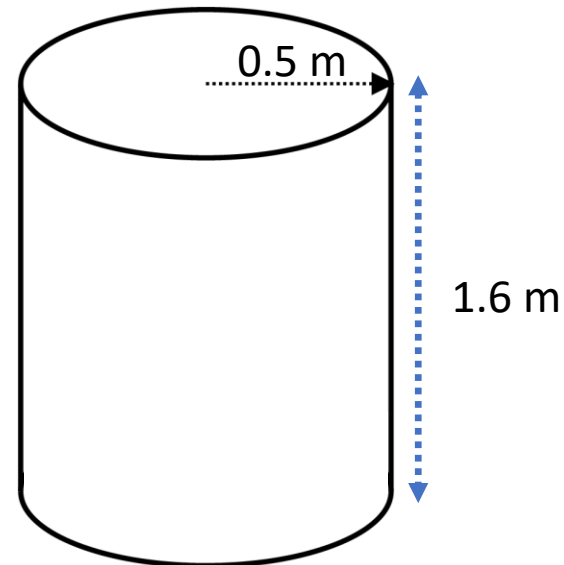

Assuming the flow continues at the same rate find the total time needed to fill the tank
(give your answer correct to the nearest second)

A full can of soup is poured into a circular pan of radius 6 cm.

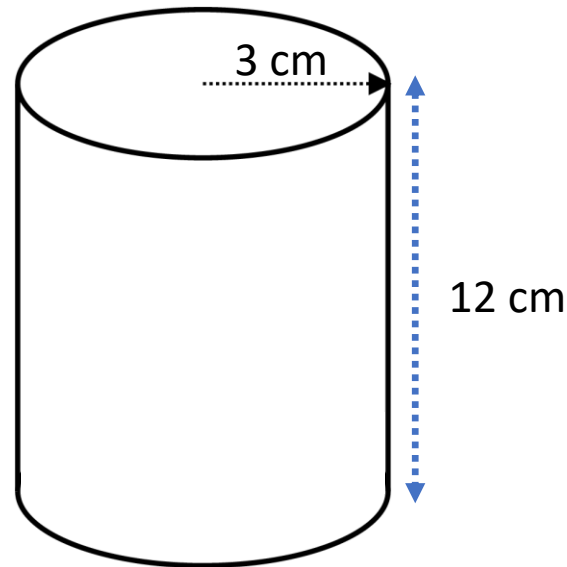

Calculate the depth of the soup in the pan.

A cover is to be knitted out of wool to cover the cylindrical foot rest (radius 25 cm, height 25 cm).

A circle of radius 15 cm can be knitted from a 50 g ball of wool. How many balls of wool will be needed to knit the full cover?

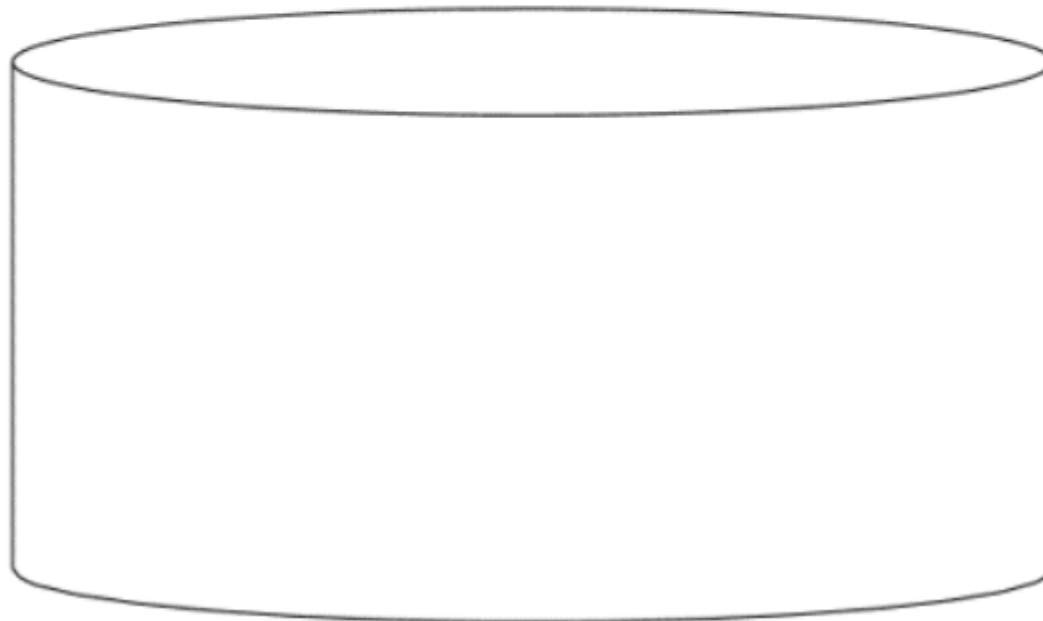

The garden plot shown below is to be filled with top soil to a depth of 60 cm. What will be the total cost?

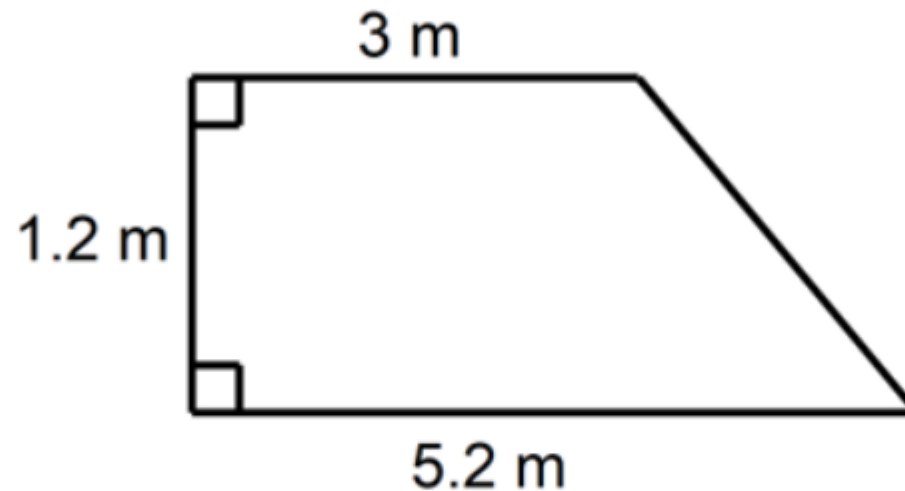

1 m³ of topsoil has a mass of 1.6 tonnes

Cost £45 per tonne

£25 delivery charge per order

The cone shown is filled with water.
The water is then poured into the cuboid.

Height = 10 cm
Radius = 3 cm

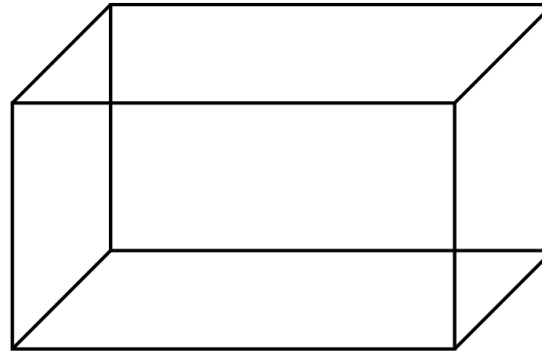
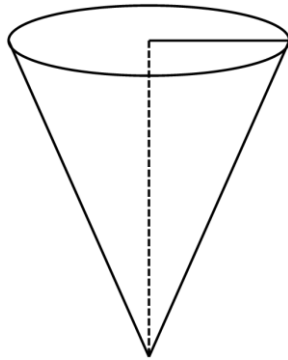

What will be the depth of water in the cuboid?